

**BIRMINGHAM CITY COMMISSION AGENDA**  
**MAY 8, 2023**  
**MUNICIPAL BUILDING, 151 MARTIN**  
**7:30 P.M.**

**I. CALL TO ORDER AND PLEDGE OF ALLEGIANCE**

Therese Longe, Mayor

**II. ROLL CALL**

Alexandria Bingham, City Clerk

**III. PROCLAMATIONS, CONGRATULATORY RESOLUTIONS, AWARDS, APPOINTMENTS, RESIGNATIONS AND CONFIRMATIONS, ADMINISTRATION OF OATHS, INTRODUCTION OF GUESTS AND ANNOUNCEMENTS.**

**ANNOUNCEMENTS**

- Proclamation Celebrating May as Jewish American Heritage Month
- Proclamation Recognizing Astrein’s Creative Jewelers for 50 Years Serving Birmingham
- On May 1, 2023, Mayor Longe recognized 33 high school and middle school students who performed community service as members of the Birmingham Youth Assistance Youth in Service Program. These students set an excellent example for their peers, and they are appreciated for their contributions to the community.
- The DPS Open House will be on Saturday, May 13, 2023, from 10 a.m. to 2 p.m. at the Public Services facility at 851 S. Eton. The event promises to be a day of family fun, offering visitors the opportunity to meet City staff, view equipment displays, and peruse informational and educational exhibits. In addition, hot dogs and refreshments will be available to enjoy.
- The 2023 Celebrate Birmingham Parade and Party will be held on Sunday, May 21, 2023 beginning with the Parade at 1 pm on N. Old Woodward near Booth Park and concluding in Shain Park, where there will be a celebration with entertainment and family-friendly activities. The festivities in Shain Park will come to a close at 4 pm.

**APPOINTMENTS**

- A. Appointment to the Board of Building Trades Appeals
1. Victor Saroki
  2. Bradley H. Klein

To appoint \_\_\_\_\_ to the Board of Building Trades Appeals as a regular member to serve the remainder of a three-year term to expire May 23, 2025.

To appoint \_\_\_\_\_ to the Board of Building Trades Appeals as a regular member to serve the remainder of a three-year term to expire May 23, 2025.

- B. Appointment to the Brownfield Redevelopment Authority
  - 1. Robert Runco

To concur with the Mayor’s appointment of \_\_\_\_\_, as a regular member to the Brownfield Redevelopment Authority to serve a three-year term to expire May 23, 2026.

To concur with the Mayor’s appointment of \_\_\_\_\_, as a regular member to the Brownfield Redevelopment Authority to serve a three-year term to expire May 23, 2026.

To concur with the Mayor’s appointment of \_\_\_\_\_, as a regular member to the Brownfield Redevelopment Authority to serve the remainder of a three-year term to expire May 23, 2024.

- C. Appointment to the Parks and Recreation Board
  - 1. Jessica Einstein
  - 2. Jane Hoffman

To appoint \_\_\_\_\_ to the Parks and Recreation Board as an alternate member to serve the remainder of a three-year term to expire March 13, 2025.

- D. Employee Recognition
  - 1. Assistant Director of Engineering – Cory Borton

**IV. OPEN TO THE PUBLIC FOR MATTERS NOT ON THE AGENDA**

**V. CONSENT AGENDA**  
All items listed on the consent agenda are considered to be routine and will be enacted by one motion and approved by a roll call vote. There will be no separate discussion of the items unless a Commissioner or citizen so requests, in which event the item will be removed from the general order of business and considered under the last item of new business.

\*Budget Hearing meeting minutes of April 29, 2023 will be available at the May 22, 2023 City Commission meeting.

- A. Resolution to approve the City Commission regular meeting minutes of April 24, 2023.
- B. Resolution to approve the warrant list, including Automated Clearing House payments, dated April 26, 2023 in the amount of \$420,133.99.
- C. Resolution to approve the warrant list, including Automated Clearing House payments, dated May 4, 2023 in the amount of \$577,736.42.
- D. Resolution to set a public hearing date of June 5, 2023 for the proposed lot combination of 36877 Woodward Ave, Gasow Veterinary Clinic, Parcel ID #19-25-101-008, 19-25-101-009, 19-25-101-010, and 19-25-101-011.
- E. Resolution to approve the Agreement with Birmingham Little League. In addition, to authorize the Mayor and Clerk to sign the agreement on behalf of the City.

- F. Resolution to authorize the City Clerk to complete the Local Approval Notice at the request of Old Woodward Ventures, LLC to approve the request of Lawrence and Eunice’s Living Trusts to transfer the membership of Old Woodward Ventures, LLC which is owned by Lawrence Bongiovanni, Trust, Kara Bongiovanni Trustee 50% and Eunice Bongiovanni, Trust Kara Bongiovanni Trustee 50%, which holds the Class C and SDM License with Sunday Sales (PM) and Outdoor Service Area located at 525 N. Old Woodward, Birmingham, Oakland County, MI to 33.34% Kara Bongiovanni Living Trust, 33.33% Lawrence and Amy Bongiovanni Living Trust and 33.33% Joseph Bongiovanni.
- G. Resolution to authorize the City Clerk to complete the Local Approval Notice at the request of Birmingham Ventures, Inc. to approve the request Eunice’s Living Trusts to transfer the stock of Birmingham Ventures, Inc. which the stock is currently held by Eunice Bongiovanni, Living Trust Kara Bongiovanni Trustee, which holds the Class C and SDM License with Sunday Sales (PM) and Outdoor Service Area located at 505 N. Old Woodward, Birmingham, Oakland County, MI to Kara Bongiovanni Living Trust, 170 shares, Lawrence and Amy Bongiovanni Living Trust 170 shares and Joseph Bongiovanni 170 shares.
- H. Resolution to approve the Intergovernmental Agreement between the City of Birmingham, the City of Auburn Hills, Bloomfield Township and the City of Rochester to establish a regional youth academy for residents and students of the four communities. Furthermore, to authorize the Chief of Police to sign the agreement on behalf of the City of Birmingham and the Birmingham Police Department.
- I. Resolution to approve the Program Year 2023 High Intensity Drug Trafficking Area (HIDTA) sub recipient agreement between the County of Oakland and the City of Birmingham. Further, to authorize the Mayor to sign the agreement on behalf of the City.
- J. Resolution to appoint Jana Ecker as Representative and Scott Zielinski as Alternate Representative of the City of Birmingham on the SOCRRA Board of Trustee for the fiscal year starting July 1, 2023.
- K. Resolution to appoint Melissa Coatta as Representative and Jana Ecker as Alternate Representative of the City of Birmingham on the SOCWA Board of Trustees for the fiscal year starting July 1, 2023.
- L. Resolution to accept the resignation of Jane Schulak from the Public Arts Board, to thank her for her service and to direct the City Clerk to begin the process of filling the vacancy.

**VI. UNFINISHED BUSINESS**

None

**VII. NEW BUSINESS**

- A. Hearing of Necessity for Sidewalk and Streetscape Special Assessment District
  - 1. WHEREAS, Notice was given pursuant to Section 94-7 of the City Code, to each owner or party-in-interest of property and lots to be assessed, by first class mail, and by publication in a newspaper generally circulated in the City; and  
  
WHEREAS, The City Commission has conducted a public hearing and has determined to proceed with the project of replacing sidewalks, reconfiguring

roadway, and street scape on Brown Street from S. Old Woodward to Woodward Ave.; and

WHEREAS, The City has previously established a policy requiring replacement or improvement of sidewalks and street scape when the City street is open for repairs or reconstruction in the Central Business District; and

WHEREAS, The City Commission, after the public hearing, has determined that the Brown Street Paving Project is a necessity and is in the best interest of the City; and

WHEREAS, The Commission has approved the detailed plans and estimates of cost prepared by the City Engineer; and

WHEREAS, Formal bids have been received and the actual cost for sidewalk and streetscape has been determined; and

WHEREAS, The City Engineer has determined the boundaries of sidewalk and streetscape located within the limits of the following streets shall be installed as part of the Brown Street Paving Project (Contract #5-23(P)):

Brown Street – S. Old Woodward to Woodward Ave.; and

WHEREAS, The formula used in making the assessment is 75% of the contractor’s charge for replacing sidewalks, reconfiguring roadway, and street scape (calculated at the rate of \$853.68 per foot of frontage property).

THEREFORE LET IT BE RESOLVED, The City Commission has determined that the scope of the public improvement as described is in the best interest of the City and will be benefit the properties listed in the assessment roll, and the City Commission directs the Manager to prepare a Special Assessment Roll and present the same to the Commission for confirmation and further set a Public Hearing and give notice on May 22, 2023.

<b>Parcel ID</b>	<b>Street Address</b>	<b>Parcel ID</b>	<b>Street Address</b>
08-19-36-208-015	325 S Old Woodward	08-19-36-206-021	255 S Old Woodward
08-19-36-208-016	355 S Old Woodward	08-19-36-207-010	34901 Woodward
08-19-36-208-004	34745 Woodward	08-19-36-206-024	Chester Parking Structure
08-19-36-206-023	Alley		

- B. Resolution to adopt the budget appropriations resolution for the City of Birmingham’s budget and establishing the total number of mills for ad valorem property taxes to be levied for the fiscal year commencing July 1, 2023 and ending June 30, 2024.

- C. Resolution to amend the Birmingham Fee Schedule to increase the rate for monthly parking at the City’s five parking garages from \$50 to \$70 at the Chester St. garage, from \$70 to \$90 at the N. Old Woodward, Park, and Peabody garages, and from \$70 to \$100 at the Pierce garage.
- D. Commission Items for Future Discussion. A motion is required to bring up the item for future discussion at the next reasonable agenda, no discussion on the topic will happen tonight.
- E. Commission discussion on items from a prior meeting.  
None.

**VIII. REMOVED FROM CONSENT AGENDA**

**IX. COMMUNICATIONS**

**X. REPORTS**

- A. Commissioner Reports
  - 1. Notice of Intention to Appoint to the Museum Board
  - 2. Notice of Intention to Appoint to the Greenwood Cemetery Advisory Board
  - 3. Notice of Intention to Appoint to the Ad Hoc Aging in Place Committee
  - 4. Notice of Intention to Appoint to the Board of Ethics
  - 5. Notice of Intention to Appoint to the Public Arts Board
- B. Commissioner Comments
- C. Advisory Boards, Committees, Commissions’ Reports and Agendas
  - 1. Birmingham Area Cable Board Annual Report, Budget, Financial Statement
- D. Legislation
- E. City Staff
  - 1. 3<sup>rd</sup> Quarter Investment Report
  - 2. 3<sup>rd</sup> Quarter Budget Report
  - 3. Recent Amendments to PA 33 - Police and Fire Protection Act
  - 4. Northwest corner of Maple and Fairfax Improvement – Pat Andrews Tribute

INFORMATION ONLY

**XI. ADJOURN**

Should you wish to participate in this meeting, you are invited to attend the meeting in person or virtually through ZOOM: <https://zoom.us/j/655079760> Meeting ID: 655 079 760

You may also present your written statement to the City Commission, City of Birmingham, 151 Martin Street, P.O. Box 3001, Birmingham, Michigan 48012-3001 prior to the hearing.

*NOTICE: Individuals requiring accommodations, such as mobility, visual, hearing, interpreter or other assistance, for effective participation in this meeting should contact the City Clerk's Office at (248) 530-1880 (voice), or (248) 644-5115 (TDD) at least one day in advance to request mobility, visual, hearing or other assistance.*

*Las personas que requieren alojamiento, tales como servicios de interpretación, la participación efectiva en esta reunión deben ponerse en contacto con la Oficina del Secretario Municipal al (248) 530-1880 por lo menos el día antes de la reunión pública. (Title VI of the Civil Rights Act of 1964).*



# PROCLAMATION

## Jewish American Heritage Month

### May 2023

**WHEREAS,** Jewish American Heritage Month is an annual celebration of Jewish Americans who have helped weave the fabric of American history, culture and society; and

**WHEREAS,** 2023 marks the 43<sup>rd</sup> annual celebration of achievements and contributions by Jewish Americans, starting with the establishment of “Jewish American Heritage Week in 1980” and expanded upon in 2006, when Congress called on the country to observe annual Jewish American Heritage Month each May; and

**WHEREAS,** Jewish American Heritage Month acknowledges achievements of American Jews and recognizes their indispensable roles in our nation’s civic and community life, making invaluable contributions to our nation through their leadership and achievements; and

**WHEREAS,** Our city recognizes that the alarming rise in antisemitism and hatred is a threat not only to the Jewish people but to all of us, and that we must foster the conditions that allow our communities to be safe, healthy and vital; and

**WHEREAS,** We offer hope and optimism through the celebration of the vibrant heritage of the Jewish Americans who have enriched our country and our communities for hundreds of years by bringing Jewish American Heritage Month to our city; and

**THEREFORE,  
BE IT RESOLVED** that I, Therese Longe, Mayor of the City of Birmingham, on behalf of the citizens of Birmingham, do hereby proclaim the month of May 2023 as Jewish American Heritage Month in Birmingham, Michigan.

*On behalf of the City of Birmingham and  
the residents of Birmingham this 8<sup>th</sup> day  
of May, 2023.*

---

*Therese Longe, Mayor*



## PROCLAMATION

### Recognizing Astrein's Creative Jewelers for 50 Years Serving Birmingham

- WHEREAS,** The City of Birmingham values long-standing businesses for their dedication and support of the Birmingham community; and
- WHEREAS,** Astrein's Creative Jewelers, locally owned and operated by Richard and Gary Astrein since 1973, have been successful business leaders in downtown Birmingham, providing exceptional personal service and products while sharing of their time and resources to make the community and the lives of the persons in the community a better place; and
- WHEREAS,** Legendary for their giving nature, Astrein's Creative Jewelers enthusiastically gave both volunteer time and financial support to countless local events, programs and charitable organizations; and
- WHEREAS,** Birmingham benefitted from their charity with notable events like the Fall Spectacular, the Village Fair, as well as creating and organizing new events that still carry on today such as Day on the Town; and
- WHEREAS,** Richard Astrein has been a vital and active Board of Director of the Birmingham Shopping District since its inception in 1992, being a founder member, a cheerleader and spokesperson for the need of a downtown management and marketing organization; and
- WHEREAS,** Richard Astrein serves in many leadership roles, including current Chairman of the BSD Special Events Committee and Member of the City of Birmingham Parking Committee, as well as beyond Birmingham serving as a Director of the Beaumont Health System and Co- Chair of the Beaumont Foundation Stars & Guitars; and

**THEREFORE,** be it resolved with this official proclamation that I, Therese Longe, Mayor of the City of Birmingham, on behalf of the City Commission, citizens and businesses of Birmingham, extend our sincere appreciation and gratitude to Astrein's Creative Jewelers and Richard Astrein for 50 years of unconditional dedication and support of the downtown Birmingham community. We wish the Astrein family all the best as they set to retire. Their commitment and passion will be sorely missed in Birmingham.

*On Behalf of the City of Birmingham and the residents and businesses of Birmingham this 8<sup>th</sup> day of May, 2023.*

Therese Longe, Mayor



**NOTICE OF INTENTION TO APPOINT TO  
BOARD OF BUILDING TRADES APPEAL**

At the regular meeting of Monday, May 8, 2023 the Birmingham City Commission intends to appoint to the Board of Building Trades Appeals two regular members to serve the remainder of three-year terms to expire May 23, 2025. Applicants shall be qualified by experience or training in fields such as architecture, engineering, mechanical engineering, building, electrical plumbing, heating or refrigeration.

Interested citizens may submit an application available at the City Clerk’s office or online at [www.bhamgov.org/boardopportunities](http://www.bhamgov.org/boardopportunities). Applications must be submitted to the City Clerk's office on or before noon on Wednesday, May 3, 2023. These documents will appear in the public agenda for the regular meeting at which time the City Commission will discuss recommendations, and may make nominations and vote on appointments.

The Board of Building Trades Appeal hears and grants or denies requests for variances from strict application of the provisions of the Michigan Building, Residential, Mechanical and Plumbing Codes and the National Electrical Code. The board will decide on matters pertaining to specific code requirements related to the construction or materials to be used in the erection, alteration or repair of a building or structure.

Applicant(s) Presented For City Commission Consideration:

<b>Applicant Name</b>	<b>Criteria/Qualifications</b>
	Applicants shall be qualified by experience or training.
Victor Saroki	Architect
Bradley H. Klein	Electrical Contractor, Master Electrician

*NOTE: All members of boards and commissions are subject to the provisions of City of Birmingham City Code Chapter 2, Article IX, Ethics and the filing of the Affidavit and Disclosure Statement.*

**SUGGESTED ACTION:**

To appoint \_\_\_\_\_ to the Board of Building Trades Appeals as a regular member to serve the remainder of a three-year term to expire May 23, 2025.

To appoint \_\_\_\_\_ to the Board of Building Trades Appeals as a regular member to serve the remainder of a three-year term to expire May 23, 2025.





# BOARD OF BUILDING TRADES APPEALS

Chapter 22, Article II, 1972 PA 230, MCL 125.1514

Members shall be qualified by experience or training (such as Architect, Engineer, Mechanical Engineer, Building Contractor, Electrical Contractor, Plumbing Contractor, Heating Contractor, and Refrigeration Contractor).

Term: Three years – 6 members

The Board of Building Trades Appeal hears and grants or denies requests for variances from strict application of the provisions of the Michigan Building, Residential, Mechanical and Plumbing Codes and the National Electrical Code. The board will decide on matters pertaining to specific code requirements related to the construction or materials to be used in the erection, alteration or repair of a building or structure.

Last Name	First Name	Home Business	E-Mail	Appointed	Term Expires
<b>Afrakhteh</b> 490 Lakeside Dr. Birmingham	<b>Arya</b> 48009		(248) 635-9925 <i>arya26@att.net</i>	6/28/2021 Builder/engineer	5/23/2024
<b>Mando</b> 5310 Heron Cove Beaverton	<b>Dennis</b> 48612		(248) 767-0515 (248) 669-4338 <i>denny@dennysonline.com</i>	1/30/2006 Heating contractor	5/23/2026
<b>Sirich</b> 1756 Melbourne Birmingham	<b>Scott H.</b> 48009		(248) 385-5398 <i>ssirich@plunkettcooney.com</i>	8/10/2020 Construction law attorney	5/23/2026
<b>Vacated</b>	<b>5/23/2022</b>				5/23/2025
<b>Vacated</b>	<b>5/23/2022</b>				5/23/2025

Last Name	First Name	Home Business	Appointed	Term Expires
<b>Wiand</b> 956 Westwood Dr. Birmingham	<b>Rick</b> 48009	(248) 766-2275  <i>rickw@hunterrobertshomes.com</i>	6/28/2021 Builder	5/23/2024



<b>OFFICE USE ONLY</b>	
Meets Requirements?	Yes No
Will Attend / Unable to Attend	

### APPLICATION FOR CITY BOARD OR COMMITTEE

Thank you for your interest in serving on a Board or Committee. The purpose of this form is to provide the City Commission with basic information about applicants considered for appointment. NOTE: Completed applications are included in the City Commission agenda packets. The information included on this form is open to the public. All Board and Committee members are subject to the provisions of the Ethics Ordinance (Chapter 2, Article IX of the City Code).

Information on various Boards and Committees and a list of current openings can be found on the City website at [www.bhamgov.org/boardopportunities](http://www.bhamgov.org/boardopportunities).

(Please print clearly)

Board/Committee of Interest Building Code Board of Appeals

Specific Category/Vacancy on Board Architect (see back of this form for information)

Name Victor Saroki

Phone 248-860-3600

Residential Address 323 Baldwin Rd

Email \* vsaroki@sarokiarchitecture.com

Residential City, Zip Birmingham, MI 48009

Length of Residence 25 years

Business Address 430 N. Old Woodward Ave.

Occupation Architect

Business City, Zip Birmingham MI 48009

Reason for Interest: Explain how your background and skills will enhance the board to which you have applied \_\_\_\_\_

Architect in City of Birmingham

List your related employment experience Architectural Firm Owner 40 year practice

List your related community activities Lawrence Technological University Trustee, Past Board Member and President for AIA Detroit and AIA Michigan Chapter's.

List your related educational experience Lawrence Technological University Undergraduate and Graduate Degree's in Architecture.

To the best of your knowledge, do you or a member of your immediate family have any direct financial or business relationships with any supplier, service provider or contractor of the City of Birmingham from which you or they derive direct compensation or financial benefit? If yes, please explain: None currently. Several years ago our firm participated with a Parking

Consultant to develop parking structure studies for the City of Birmingham.

Do you currently have a relative serving on the board/committee to which you have applied? No

Are you an elector (registered voter) in the City of Birmingham? Yes

  
 \_\_\_\_\_  
 Signature of Applicant

4/20/2023  
 \_\_\_\_\_  
 Date

Return the completed and signed application form to: City of Birmingham, City Clerk's Office, 151 Martin, Birmingham, MI 48009 or by email to [clerksoffice@bhamgov.org](mailto:clerksoffice@bhamgov.org) or by fax to 248.530.1080.

\*By providing your email to the City, you agree to receive news & notifications from the City. If you do not wish to receive these messages, you may unsubscribe at any time.

**APPLICATION FOR CITY BOARD OR COMMITTEE**

Thank you for your interest in serving on a Board or Committee. The purpose of this form is to provide the City Commission with basic information about applicants considered for appointment. NOTE: Completed applications are included in the City Commission agenda packets. The information included on this form is open to the public. All Board and Committee members are subject to the provisions of the Ethics Ordinance (Chapter 2, Article IX of the City Code).

Information on various Boards and Committees and a list of current openings can be found on the City website at [www.bhamgov.org/boardopportunities](http://www.bhamgov.org/boardopportunities).

(Please print clearly)

Board/Committee of Interest Construction Review Board (Board of Building Trades Appeal)

Specific Category/Vacancy on Board \_\_\_\_\_ (see back of this form for information)

Name Bradley H. Klein

Phone (248) 863-6302 (Cell)

Residential Address 5063 Parkside Drive

Email \* bklein@kleinelectric.net

Residential City, Zip West Bloomfield, MI 48323

Length of Residence 13 years

Business Address 2044 Winner St.

Occupation Electrical Contractor/Master Electrician

Business City, Zip Commerce, MI 48390

Reason for Interest: Explain how your background and skills will enhance the board to which you have applied \_\_\_\_\_

Interest in construction and the application of codes and prior member of this board

List your related employment experience Familiar with the installation of electrical in both the residential and commercial installations and also have provided consulting services for repairs in the insurance restoration business.

List your related community activities Electrical Contractor (EC), also known at times as an Electrical Charity

List your related educational experience Bachelor of Science, Psychology from The University of Michigan, Ann Arbor  
State of Michigan Master Electrician, State of Michigan Electrical Contractor

To the best of your knowledge, do you or a member of your immediate family have any direct financial or business relationships with any supplier, service provider or contractor of the City of Birmingham from which you or they derive direct compensation or financial benefit? If yes, please explain: No

Do you currently have a relative serving on the board/committee to which you have applied? Myself?

Are you an elector (registered voter) in the City of Birmingham? No

Bradley H. Klein  
Signature of Applicant

April 20, 2023  
Date

Return the completed and signed application form to: City of Birmingham, City Clerk's Office, 151 Martin, Birmingham, MI 48009 or by email to [clerk@bhamgov.org](mailto:clerk@bhamgov.org) or fax to 248.530.1080.

Updated 11/18/2020

\*By providing your email to the City, you agree to receive **3A** notifications from the City. If you do not wish to

**STILLE-DEROSSETT-HALE SINGLE STATE CONSTRUCTION CODE ACT (EXCERPT)**  
**Act 230 of 1972**

**125.1514 Construction board of appeals; creation; appointment, qualifications, and terms of members; appeal to board; hearing; decision; statement of reasons for decision; appeal to commission; copy of decision; additional powers or duties; procedures; conducting business at public meeting; notice; availability of certain writings to public.**

Sec. 14. (1) A construction board of appeals for each governmental subdivision enforcing the code shall be created consisting of not less than 3 nor more than 7 members, as determined by the governing body of the governmental subdivision. Unless otherwise provided by local law or ordinance, the members of the board of appeals shall be appointed for 2-year terms by the chief executive officer of a city, village, or township and the chairperson of the county board of commissioners of a county. A member of the board of appeals shall be qualified by experience or training to perform the duties of members of the board of appeals. A person may serve on the board of appeals of more than 1 governmental subdivision. If an enforcing agency refuses to grant an application for a building permit, or if the enforcing agency makes any other decision pursuant or related to this act, or the code, an interested person, or the person's authorized agent, may appeal in writing to the board of appeals. The board of appeals shall hear the appeal and render and file its decision with a statement of reasons for the decision with the enforcing agency from whom the appeal was taken not more than 30 days after submission of the appeal. Failure by the board of appeals to hear an appeal and file a decision within the time limit is a denial of the appeal for purposes of authorizing the institution of an appeal to the commission. A copy of the decision and statement of the reasons for the decision shall be delivered or mailed, before filing, to the party taking the appeal.

(2) This act does not prevent a governmental subdivision from granting its board of appeals additional powers or duties not inconsistent with this act, or from establishing procedures to be followed by its board of appeals insofar as the procedures do not conflict with this act. Except as otherwise provided by this act, or by other laws or ordinances, a board of appeals may by rules establish its own procedures.

(3) The business which the board of appeals may perform shall be conducted at a public meeting of the board of appeals held in compliance with Act No. 267 of the Public Acts of 1976. Public notice of the time, date, and place of the meeting shall be given in the manner required by Act No. 267 of the Public Acts of 1976.

(4) A record of decisions made by the board of appeals, properly indexed, and any other writing prepared, owned, used, in the possession of, or retained by the board of appeals in the performance of an official function shall be made available to the public in compliance with Act No. 442 of the Public Acts of 1976.

**History:** 1972, Act 230, Eff. Jan. 1, 1973;—Am. 1977, Act 195, Imd. Eff. Nov. 17, 1977;—Am. 1978, Act 442, Imd. Eff. Oct. 9, 1978.

**Popular name:** Act 230

**Popular name:** Uniform Construction Code



**NOTICE OF INTENTION TO APPOINT TO THE  
CITY OF BIRMINGHAM  
BROWNFIELD REDEVELOPMENT AUTHORITY**

At the regular meeting of Monday, May 8, 2023 the Birmingham City Commission intends to appoint to the Brownfield Redevelopment Authority two regular member to serve three-year term to expire May 23, 2026 and one regular member to serve the remainder of a three-year term to expire May 23, 2024.

The authority shall have the powers and duties to the full extent as provided by and in accordance with the provisions of the Brownfield Redevelopment Financing Act, being Act 381 of the Public Acts of the state of Michigan of 1996, as amended. Among other matters, in the exercise of its powers, the Board may prepare Brownfield plans pursuant to Section 13 of the Act and submit the plans to the Commission for consideration pursuant to Section 13 and 14 of the Act.

**Members shall be appointed by the Mayor, subject to approval by the City Commission.**

Interested citizens may submit an application available at the city clerk’s office or online at [www.bhamgov.org/boardopportunities](http://www.bhamgov.org/boardopportunities). Applications must be submitted to the city clerk's office on or before noon on Wednesday, May 3, 2023. These documents will appear in the public agenda for the regular meeting at which time the City Commission will discuss recommendations, and may make nominations and vote on appointments.

Applicant(s) Presented For City Commission Consideration:

<b>Applicant Name</b>	<b>Criteria/Qualifications</b>
Robert Runco	Current regular member, Resident at 1556 Lakeside Drive

*NOTE: All members of boards and commissions are subject to the provisions of City of Birmingham City Code Chapter 2, Article IX, Ethics and the filing of the Affidavit and Disclosure Statement.*

The following board member will not be continuing on the board. We thank them for their service to the community:

- Beth Gotthelf, Appointed 2005

**SUGGESTED ACTION:**

To concur with the Mayor's appointment of \_\_\_\_\_, as a regular member to the Brownfield Redevelopment Authority to serve a three-year term to expire May 23, 2026.

To concur with the Mayor's appointment of \_\_\_\_\_, as a regular member to the Brownfield Redevelopment Authority to serve a three-year term to expire May 23, 2026.

To concur with the Mayor's appointment of \_\_\_\_\_, as a regular member to the Brownfield Redevelopment Authority to serve the remainder of a three-year term to expire May 23, 2024.



# BROWNFIELD REDEVELOPMENT AUTHORITY

Resolution # 04-123-05

5 members, three-year terms, appointed by the mayor subject to approval of the commission.

The authority shall have the powers and duties to the full extent as provided by and in accordance with the provisions of the Brownfield Redevelopment Financing Act, being Act 381 of the Public Acts of the state of Michigan of 1996, as amended. Among other matters, in the exercise of its powers, the Board may prepare Brownfield plans pursuant to Section 13 of the Act and submit the plans to the Commission for consideration pursuant to Section 13 and 14 of the Act.

Last Name	First Name	Home Business E-Mail	Appointed	Term Expires
<b>Awdey</b> 1633 Graefield	<b>Harry</b>	(586) 453-4677 <i>hawdey@gmail.com</i>	9/25/2017	5/23/2025
<b>Gotthelf</b> 363 Catalpa	<b>Beth</b>	(248) 227.6920 <i>gotthelf@butzel.com</i>	5/9/2005	5/23/2023
<b>Runco</b> 1556 Lakeside	<b>Robert</b>	(248) 388-8100 <i>rrunco@runcowaste.com</i>	5/9/2005	5/23/2023
<b>Torcolacci</b> 2047 Windemere	<b>Daniella</b>	(248) 217-4805 <i>dtorcolacci@gmail.com</i>	10/27/2014	5/23/2025
<b>Vacated</b>	<b>3/1/2022</b>			5/23/2024





**NOTICE OF INTENTION TO APPOINT TO THE  
PARKS AND RECREATION BOARD**

At the regular meeting of Monday, May 8, 2023, the Birmingham City Commission intends to appoint to the Parks and Recreation Board an alternate member to serve the remainder of a three-year term expiring on March 13, 2025.

Interested citizens may submit an application available at the City Clerk’s office or online at [www.bhamgov.org/boardopportunities](http://www.bhamgov.org/boardopportunities). Applications must be submitted to the City Clerk's office on or before noon on Wednesday, May 3, 2023. These applications will appear in the public agenda for the regular meeting at which time the City Commission will discuss recommendations, and may make nominations and vote on the appointments.

Responsibilities

The Parks & Recreation Board consists of seven members and two alternate members who serve for three-year terms without compensation. The goal of the board is to promote a recreation program and a park development program for the City of Birmingham. The Board shall recommend to the City Commission for adoption such rules and regulations pertaining to the conduct and use of parks and public grounds as are necessary to administer the same and to protect public property and the safety, health, morals, and welfare of the public.

The meetings are held the first Tuesday of the month at 6:30 P.M.

*NOTE: All members of boards and commissions are subject to the provisions of City of Birmingham City Code Chapter 2, Article IX, Ethics and the filing of the Affidavit and Disclosure Statement.*

Applicant(s) Presented for City Commission Consideration:

<b>Applicant Name</b>	<b>Criteria</b>	<b>Qualifications</b>
	Members must be electors (registered voters) of the City of Birmingham	
Jessica Einstein	Birmingham Elector	Start-Up Executive, Marketing background, young family focus
Jane Hoffman	Birmingham Elector	Attorney, Masters in City Planning

**SUGGESTED ACTION:**

To appoint \_\_\_\_\_ to the Parks and Recreation Board as an alternate member to serve the remainder of a three-year term to expire March 13, 2025.

# PARKS AND RECREATION BOARD

Article II, Section 78

Objectives: The Parks and Recreation Board shall promote a recreation program and a park development program for the City. The Board shall recommend to the city commission for adoption such rules and regulations pertaining to the conduct and use of parks and public grounds as are necessary to administer the same and to protect public property and the safety, health, morals, and welfare of the public.

Seven regular members, Three-year Terms, Appointed by the City Commission

Two alternate members, Three-year Terms, Appointed by the City Commission

Members must be electors of the City of Birmingham

Meetings held the first Tuesday of each month at 6:30 PM.

Last Name	First Name	Home Address	Home Business E-Mail	Appointed	Term Expires
<b>Carmona</b>	<b>Heather</b>	887 Lakeview Ave.	(248) 867-1346  <i>htcarmona@sbcglobal.net</i>	3/12/2018 Regular Member	3/13/2024
<b>Collins</b>	<b>Susan</b>	958 Pleasant	(248) 761-6873  <i>sbdcollins@comcast.net</i>	3/9/2020 Regular Member	3/13/2024
<b>Glasier</b>	<b>Kate</b>			2/27/2023 Student representative	12/31/2023
<b>Graham</b>	<b>Pam</b>	884 Knox	(248) 408-6277  <i>pamcracker@gmail.com</i>	1/13/2020 Regular Member	3/13/2026

Last Name	First Name	Home Business E-Mail	Appointed	Term Expires
<b>Kupczyk</b> 592 W Lincoln	<b>Sarah</b>	(773)414-4727  <i>sc23carroll@gmail.com</i>	3/27/2023 Regular Member	3/13/2026
<b>Lipp</b> 2682 Buckingham	<b>Anne</b>	(248) 225-0136  <i>aecubera@gmail.com</i>	11/23/2020 Regular Member	3/13/2025
<b>Reynolds</b>	<b>Archie</b>		2/27/2023 Student representative	12/31/2023
<b>Rusche</b> 358 Henley St.	<b>John</b>	(248) 731-7068 (248) 219-8114  <i>jprusche@aol.com</i>	9/6/2018 Regular Member	3/13/2024
<b>Sweeney</b> 160 Larchlea Ave	<b>Steve</b>	(248) 875-9973  <i>stevesweeney22@yahoo.com</i>	3/28/2022 Regular Member	3/13/2026
<b>Vacated</b>	<b>3/27/2023</b>		Alternate	3/13/2025

<b>Last Name</b>	<b>First Name</b>	<b>Home Business</b>	<b>Appointed</b>	<b>Term Expires</b>
<b>Home Address</b>		<b>E-Mail</b>		
<b>Wrobel</b>	<b>Joe</b>	(248)225-5937	4/3/2023	3/13/2026
2665 Windemere			Alternate	
		<i>wrobel4j@aol.com</i>		

---

**OFFICE USE ONLY**  
 Meets Requirements? Yes No  
 Will Attend / Unable to Attend

## APPLICATION FOR CITY BOARD OR COMMITTEE

Thank you for your interest in serving on a Board or Committee. The purpose of this form is to provide the City Commission with basic information about applicants considered for appointment. NOTE: Completed applications are included in the City Commission agenda packets. The information included on this form is open to the public. All Board and Committee members are subject to the provisions of the Ethics Ordinance (Chapter 2, Article IX of the City Code).

Information on various Boards and Committees and a list of current openings can be found on the City website at [www.bhamgov.org/boardopportunities](http://www.bhamgov.org/boardopportunities).

(Please print clearly)

Board/Committee of Interest Parks & Recreation Board

Specific Category/Vacancy on Board Alternate Member (see back of this form for information)

Name Jessica Einstein Phone 248-821-0306

Residential Address 419 Pilgrim Avenue Email \* jessicaeinstein@gmail.com

Residential City, Zip Birmingham, MI 48009 Length of Residence 2.5 years in Birmingham

Business Address \_\_\_\_\_ Occupation Start up executive

Business City, Zip \_\_\_\_\_

Reason for Interest: Explain how your background and skills will enhance the board to which you have applied \_\_\_\_\_

I grew up here and have two young children who I'm raising in Birmingham. We spend a lot of time outside at parks and I'm keenly interested in ways to bring the community together.

List your related employment experience I run customer experience and talent for a technology start up. My background is in building and scaling tech companies largely through marketing and community functions.

List your related community activities In Washington DC, I served on the board of the YMCA, Anthony Bowen where I focused on supporting the YMCA in developing curriculum and resources for young families to come together and have support

List your related educational experience I went to Birmingham Schools (quarton, derby, seaholm) - Studied Philosophy and Sociology at Denison University

To the best of your knowledge, do you or a member of your immediate family have any direct financial or business relationships with any supplier, service provider or contractor of the City of Birmingham from which you or they derive direct compensation or financial benefit? If yes, please explain: \_\_\_\_\_

no

Do you currently have a relative serving on the board/committee to which you have applied? no

Are you an elector (registered voter) in the City of Birmingham? yes

[Signature] 4/5/2023  
 Signature of Applicant Date

Return the completed and signed application form to: City of Birmingham, City Clerk's Office, 151 Martin, Birmingham, MI 48009 or by email to [clerk@bhamgov.org](mailto:clerk@bhamgov.org) or fax to 248.530.1080. Updated 11/18/2020

*\*By providing your email to the City, you agree to receive news & notifications from the City. If you do not wish to receive these messages, you may unsubscribe at any time.*

**APPLICATION FOR CITY BOARD OR COMMITTEE**

Thank you for your interest in serving on a Board or Committee. The purpose of this form is to provide the City Commission with basic information about applicants considered for appointment. NOTE: Completed applications are included in the City Commission agenda packets. The information included on this form is open to the public. All Board and Committee members are subject to the provisions of the Ethics Ordinance (Chapter 2, Article IX of the City Code).

Information on various Boards and Committees and a list of current openings can be found on the City website at [www.birmingham.gov](http://www.birmingham.gov).

(Please print clearly)

Board/Committee of Interest Parks and Recreation Board

Specific Category/Vacancy on Board Regular Member or (see back of this form for information)  
Alternate Member

Name Jane Hoffman Phone 248-880-9609

Residential Address 2324 Buckingham Ave. Email \* j3Hoffman14@gmail.com

Residential City, Zip Birmingham, MI 48009 Length of Residence 8 years

Business Address \_\_\_\_\_ Occupation Attorney

Business City, Zip \_\_\_\_\_

Reason for Interest: Explain how your background and skills will enhance the board to which you have applied \_\_\_\_\_

Interest in supporting Birmingham and our parks and recreation endeavors

I have a master in city planning, so I know a bit about zoning and planning; I also have a law degree, which may be useful.

List your related employment experience Primarily work on regulatory and commercial contracts and disputes.

List your related community activities Volunteer for a few ministries at Church and at events coordinated by my employer of Habitat for Humanity.

List your related educational experience Master of City Planning from The Ohio State University, J.D. from The University of Cincinnati College of Law

To the best of your knowledge, do you or a member of your immediate family have any direct financial or business relationships with any supplier, service provider or contractor of the City of Birmingham from which you or they derive direct compensation or financial benefit? If yes, please explain: NO

Do you currently have a relative serving on the board/committee to which you have applied? No

Are you an elector (registered voter) in the City of Birmingham? yes

Signature of Applicant Jane Hoffman Date 4/1/2023

Return the completed and signed application form to: City of Birmingham, City Clerk's Office, 151 Martin, Birmingham, MI 48009 or by email to [cityclerk@birmingham.gov](mailto:cityclerk@birmingham.gov) or fax to 248.530.1080. Updated 11/18/2020

\*By providing your email to the City, you agree to receive **BCS** & notifications from the City. If you do not wish to receive these messages, you may unsubscribe at any time.

## **ARTICLE II. PARKS AND RECREATION BOARD<sup>1</sup>**

### **Sec. 78-26. Created; composition.**

There is hereby created a parks and recreation board consisting of the city manager and the director of public services or their designated representatives as nonvoting ex-officio members, and seven members, who are electors in the city, appointed by the city commission.

The city commission may appoint two alternate members to serve as needed on the parks and recreation board during their term of appointment. An alternate member may be called on a rotating basis to sit as a regular member of the parks and recreation board in the absence of a regular member. An alternate member may also be called to service in the place of a regular member for the purpose of reaching a decision on a case in which the regular member has abstained for reasons of conflict of interest. An alternate member having been appointed shall serve in the case until a final decision has been made. An alternate member shall have the same voting rights as a regular member of the parks and recreation board.

(Code 1963, § 3.21; Ord. No. 2233, 5-22-17)

### **Sec. 78-27. Terms of members; vacancies.**

The initial members of the parks and recreation board shall be appointed for the following terms: Two for one year, two for two years, and three for three years. Thereafter, all such appointments, except to fill vacancies, shall be for a term of three years. All appointments for the purpose of filling vacancies occurring otherwise than by expiration of term of office, shall be for the unexpired term.

(Code 1963, § 3.21)

### **Sec. 78-28. Organization.**

Within 15 days after the appointment of members to the original parks and recreation board and within 15 days after the making of annual appointments to the board, the members of the board shall meet in regular session and elect from the members a chairman who shall be the presiding officer of the board, and a vice-chairman who shall serve in the absence of the chairman. A secretary who shall keep and maintain the minutes and records of the board shall also be elected. The secretary need not be a member of the board. The terms of office for such officers shall be one year and until their successors have been elected, and there shall be no limitation upon successive elections of the same person to any office. The ex-officio members of the board may not act as chairman or vice-chairman but may act as secretary.

(Code 1963, § 3.22)

---

<sup>1</sup>Cross reference(s)—Boards and commissions, § 2-171 et seq.

---

### **Sec. 78-29. Compensation.**

All members of the parks and recreation board, except ex-officio members, shall serve without compensation.

(Code 1963, § 3.23)

### **Sec. 78-30. Meetings and quorum.**

The parks and recreation board shall set a time for a regular meeting at least once each month and shall determine the manner in which special meetings may be noticed and held. The chairman may cancel a meeting if there is no matter requiring consideration by the board. A quorum for the transaction of business at the regular and special meetings shall be five members, at least one of whom shall be an ex-officio member or his designated representative.

(Code 1963, § 3.24; Ord. No. 2022, 2-22-10)

### **Sec. 78-31. Objectives and duties.**

The parks and recreation board shall promote a recreation program and a park development program for the city. In carrying out these objectives it shall:

- (1) Serve as a forum for the consideration of policy matters related to the operation of a park and recreation program.
- (2) Advise the public with regard to the policies established by the city commission relating to the park and recreation program.
- (3) Serve in advisory capacity to the city commission in regard to all matters affecting parks and recreation which are referred to it by the city commission.
- (4) Recommend to the city commission a recreation program, fee schedules, and the adoption of a long-range program for the development of park areas and facilities.
- (5) Recommend to the city commission hours of operation and allocation of facility use.

(Code 1963, § 3.25)

### **Sec. 78-32. Regulations.**

The parks and recreation board shall recommend to the city commission for adoption such rules and regulations pertaining to the conduct and use of parks and public grounds as are necessary to administer the same and to protect public property and the safety, health, morals, and welfare of the public. The violation of any such duly adopted rule or regulation by any party shall be deemed to constitute a violation of this section.

(Code 1963, § 3.26)

### **Sec. 78-33. Scope of authority.**

The parks and recreation board is a nonadministrative board serving solely in an advisory capacity. In that capacity, the board may make recommendations to the city commission but may not assume any legislative or



---

administrative authority in the operation of any city department, park, or recreation facility except as specifically provided in this article.

(Code 1963, § 3.27)

**Secs. 78-34—78-55. Reserved.**

***EXCERPT***  
**BIRMINGHAM CITY COMMISSION MINUTES**  
**MAY 22, 2017**  
**MUNICIPAL BUILDING, 151 MARTIN**  
**7:30 P.M.**

**I. CALL TO ORDER AND PLEDGE OF ALLEGIANCE**

Mayor Mark Nickita called the meeting to order at 7:30 PM.

**II. ROLL CALL**

ROLL CALL: Present,	Mayor Nickita Mayor Pro Tem Harris Commissioner Bordman Commissioner Boutros Commissioner DeWeese Commissioner Hoff Commissioner Sherman
Absent,	None

Administration: City Manager Valentine, City Attorney Currier, City Clerk Brown, Police Commander Grewe, City Planner Ecker, Finance Director Gerber, Assistant to the City Manager Haines, City Engineer O'Meara, Library Director Koschik

**05-139 -17 USE OF ALTERNATES, REPORTING BOARD ATTENDANCE, AND MODIFYING REQUIREMENTS FOR BOARD MEMBERS**

Assistant to the City Manager Haines presented results of a review of board and committee attendance suggesting that three groups might benefit from having two alternate positions added to increase attendance and/or achieve quorum: 1) Advisory Parking Committee, 2) Parks and Recreation Board, and 3) Public Arts Board.

Assistant to the City Manager Haines also presented, based on review of current methods of using alternates, the following recommended process for use of alternates to be consistent for all boards and committees, with the exception of the Zoning Board of Appeals.

1. Alternates are to be called on a rotating basis to sit as a regular member in the absence of a regular member.
2. Alternates are provided the same access (printed or electronic) to the agenda packet as regular members, regardless if they have been called to sit in as an alternate or not.
3. Alternates are to be contacted with as much lead time before the meeting date as possible. Staff will ask during each meeting if any regular member is planning to be absent at the upcoming meeting. Staff will also email regular members at least two days prior to the meeting date to confirm attendance. The appropriate alternate (using a rotating schedule) is contacted by staff and confirms or denies the offer to sit in. A record of their attendance is maintained by staff based on if they were called and turned down the opportunity; then it would count as an absence. Not being asked does not constitute an absence and would be left blank in the attendance record.
4. Alternates are expected to be familiar with current board issues either by attending live meetings, watching live broadcast remotely, reviewing archived video recordings of the

meetings, or by reading the meeting minutes. In meetings where an issue discussed will be continued at a future meeting, it is appropriate to require that same alternate to come back, and the regular member to recuse his or herself based on their earlier absence.

5. Alternates under consideration for selection and addition to a committee or board, must meet one of the already established criteria for one of the regular members.

Commissioner Hoff asked why the rosters for some boards were included in the packet, and Assistant to the City Manager Haines explained the Commission had asked which boards used the language "in so far as possible" in regards to qualifications for appointment.

Commissioner Hoff stated the requirement for alternates to be aware of issues is an important point.

Commissioner Bordman advocated for alternates being required to attend all meetings, explaining that being present in the meeting room will elevate the status of alternates, promote comradery between the alternates and the regular board members, establish continuity in discussions, and allow alternates to be fully prepared. She further proposed that every member of a board or committee who misses a meeting be required to either read the minutes or watch the video of the meeting in order to keep up.

Regarding attendance:

- Commissioner Boutros noted the importance of enforcing attendance of regular members as well as alternates, and suggested a minimum attendance requirement for reappointment eligibility.
- Mayor Nickita said attendance is documented for all appointees. He was not in favor of instituting a minimum attendance requirement, but suggested the Commission review attendance to determine whether or not reappointing a member would be appropriate.
- Commissioner DeWeese concurred that attendance be taken for both regular and alternate members, and believed recording attendance results in self-adjustment. He recommended the attendance recording document contain no blanks, as blanks signify something missed.

The Commission was generally in favor of Commissioner Bordman's requirement for alternates to attend all meetings and discussed ways in which to implement the requirement into recommended process for use of alternates. Commissioner Sherman suggested Assistant to the City Manager Haines revise the policy in conformity with the Commission's discussion, rather than either the Commission trying to draft new language at the table, or having staff bring a revised policy back.

Assistant to the City Manager Haines summarized the discussion, noting the Commission wants clarification that alternates are required to attend all meetings, that a record of attendance of both alternates and regular members be maintained, and that the language is clear that the expectation of the alternate is the same level as that of a regular member.

**MOTION:** Motion by Commissioner Bordman, seconded by Mayor Pro Tem Harris:  
To amend the ordinances of the Advisory Parking Committee, the Parks and Recreation Board, and the Public Arts Board, to add 2 alternate positions to each as follows:

To amend Resolution No. 08-882-84 – August 6, 1984, Advisory Parking Committee, Members.

**AND**

To amend Part II of the City Code, Chapter 78, Parks and Recreation, Article II., Parks and Recreation Board, Section 78-26, Created; composition.

**AND**

To amend Part II of the City Code, Chapter 78, Public Arts Board, Article V., Public Arts Board, Section 78-103, Composition and terms of members.

**AND**

To direct the city clerk to standardize the attendance reporting of all city boards and committees as outlined in the May 12, 2017 memorandum to the city manager and as clarified by the Commission and to direct staff to amend the Recommended Process for Use of Alternates as clarified by Commissioner Bordman.

VOTE:           Yeas,       7  
                  Nays,        0  
                  Absent,    0

CITY OF BIRMINGHAM

ORDINANCE NO. 2233

**AN ORDINANCE TO AMEND PART II OF THE CITY CODE, CHAPTER 78 PARKS AND RECREATION, ARTICLE II. PARKS AND RECREATION BOARD, SECTION 78-26 CREATED; COMPOSITION.**

THE CITY OF BIRMINGHAM ORDAINS:

Part II of the City Code, Chapter 78 Parks and Recreation Board, Article II. Parks and Recreation Board, Section 78-26 Composition, as follows:

ARTICLE II. – PARKS AND RECREATION BOARD

Sec. 78-26. – Created; composition.

There is hereby created a parks and recreation board consisting of the city manager and the director of public services or their designated representatives as nonvoting ex-officio members, and seven members, who are electors in the city, appointed by the city commission.

**The city commission may appoint two alternate members to serve as needed on the Parks and Recreation Board during their term of appointment. An alternate member may be called on a rotating basis to sit as a regular member of the Parks and Recreation Board in the absence of a regular member. An alternate member may also be called to service in the place of a regular member for the purpose of reaching a decision on a case in which the regular member has abstained for reasons of conflict of interest. An alternate member having been appointed shall serve in the case until a final decision has been made. An alternate member shall have the same voting rights as a regular member of the Parks and Recreation Board.**

All other Sections of Chapter 78 Parks and Recreation Board shall remain unaffected.

Ordained this 22<sup>nd</sup> day of May, 2017. Effective upon publication.

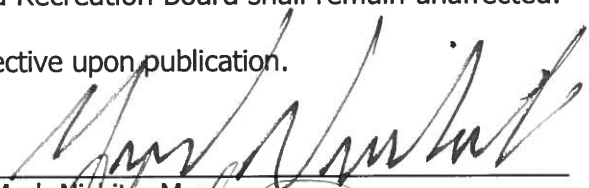
  
\_\_\_\_\_  
Mark Nickita, Mayor

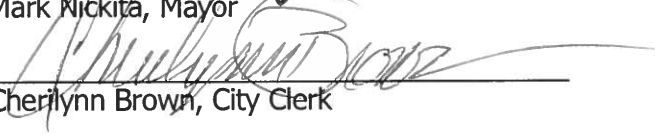
  
\_\_\_\_\_  
Cherilynn Brown, City Clerk

I, Cherilynn Brown, City Clerk of the City of Birmingham, do hereby certify that the foregoing ordinance was passed by the Commission of the City of Birmingham, Michigan at a regular meeting held 5-22-17 and that a summary was published on June 4, 2017.

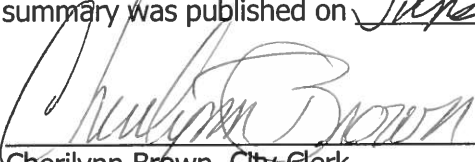
  
\_\_\_\_\_  
Cherilynn Brown, City Clerk



## **Expectations of Alternates on City Boards or Committees**

The following guidelines have been adopted from the May 22, 2017 Birmingham City Commission meeting. The Commission gave direction regarding alternates being required to attend all meetings, explaining that by being present in the room, it will elevate the status of alternates, promote comradery between the alternates and the regular board members, establish continuity in discussions, and allow alternates to be fully prepared. Further, it was proposed that every member of a board or committee who misses a meeting be required to either read the minutes or watch the video of the meeting in order to keep up. The expectation of the alternate is the same level of that of a regular member. The expectations are as follows:

1. Alternates are expected to attend all meetings of their appointed board just as regular members are expected to attend all meetings. Alternates are to be utilized on a rotating basis to sit as a regular member in the absence of a regular member, except the Board of Zoning Appeals (BZA) may continue the existing practice of utilizing alternates by seniority.
2. Alternates are provided the same access (printed or electronic) to the agenda packet as regular members.
3. A record of attendance for all members, regular and alternates, is maintained by the staff person assigned to each board. If a member or an alternate cannot make a meeting, he or she should contact the staff person and advise them of their intended absence.
4. In meetings where an issue discussed will be continued at a future meeting, and an alternate was utilized for that specific meeting, it is appropriate that the same alternate be utilized for that issue, and the regular member to recuse his or herself for that issue based on their earlier absence.
5. Alternates under consideration for selection and addition to a committee or board as a regular member, must meet one of the already established criteria for one of the regular members.



## **MEMORANDUM**

Engineering Department

**DATE:** May 8, 2023

**TO:** Thomas M. Markus, City Manager

**FROM:** Melissa A. Coatta, City Engineer

**SUBJECT:** Introduction to City Commission – Assistant Director of Engineering

---

### INTRODUCTION:

The Engineering Department had a vacancy for an Assistant Director of Engineering in December 2022 when Scott Zielinski was promoted to Director of the Department of Public Services. The City held external and internal job posting and an interview process, and Cory Borton was the top candidate for Assistant Director of Engineering.

Cory Borton has over 23 years of experience in civil engineering. For eighteen years, he worked at an engineering consulting firm specializing in municipal engineering. His tasks include general engineering services, MS4 and NPDES permitting, soil erosion and sedimentation Control programs, sewer investigation and rehabilitation program, and plan reviews for several communities. His last five and half years were at Charter Township of Bloomfield as their Asset Management Coordination in the Engineering and Environmental Services Department where he was responsible for the implementation of asset management plans for water and sewer systems, managing water and sewer projects, MS4 permitting, and plan reviews for water and sewer connection, ordinance compliance, wetland, and tree and natural features.

Cory has a bachelor's degree in Environmental Science from Central Michigan University and a master's degree in Urban Planning from Wayne State University.

**Birmingham City Commission Minutes**  
**April 24, 2023**  
**Municipal Building, 151 Martin**  
**7:30 p.m.**  
**Vimeo Link: <https://vimeo.com/820766927>**

**I. CALL TO ORDER AND PLEDGE OF ALLEGIANCE**

Therese Longe, Mayor, opened the meeting with the Pledge of Allegiance.

**II. ROLL CALL**

City Clerk Bingham called the roll.

Present: Mayor Longe  
Mayor Pro Tem McLain  
Commissioner Baller  
Commissioner Boutros  
Commissioner Haig  
Commissioner Host  
Commissioner Schafer

Absent: None

Staff: City Manager Markus; Senior Planner Cowan, Planning Director Dupuis, Assistant City Manager Ecker, Finance Director Gerber, City Attorney Kucharek, Fire Marshal Scaife, Fire Chief Wells

**III. PROCLAMATIONS, CONGRATULATORY RESOLUTIONS, AWARDS, APPOINTMENTS, RESIGNATIONS AND CONFIRMATIONS, ADMINISTRATION OF OATHS, INTRODUCTION OF GUESTS AND ANNOUNCEMENTS**

**Announcements**

- The City recommends members of the public wear a mask if they have been exposed to COVID-19 or have a respiratory illness. City staff, City Commission and all board and committee members must wear a mask if they have been exposed to COVID-19 or actively have a respiratory illness. The City continues to provide KN-95 respirators and triple-layered masks for attendees.
- Arbor Day Celebration Proclamation
- Arab American Heritage Month Proclamation
- Chaldean-American Month Proclamation
- Clerk Week Proclamation

**Appointments**

Neither Dennis Mando or Scott H. Sirich were available for interviews for the Board of Building Trades Appeals Appointments. The Mayor noted these would be reappointments and asked the Commission if they were interested in making nominations.

**04-083-23 Board of Building Trades Appeals Appointment**



**MOTION:** Nomination by MPT Boutros:  
To appoint Dennis Mando to the Board of Building Trades Appeals as a regular member to serve a three-year term to expire May 23, 2026.

VOICE VOTE:           Ayes, MPT McLain  
                                  Commissioner Boutros  
                                  Commissioner Host  
                                  Mayor Longe  
                                  Commissioner Haig  
                                  Commissioner Schafer  
                                  Commissioner Baller

Nays, None

**04-084-23 Board of Building Trades Appeals Appointment**

**MOTION:** Nomination by MPT McLain:  
To appoint Scott H. Sirich to the Board of Building Trades Appeals as a regular member to serve a three-year term to expire May 23, 2026.

VOICE VOTE:           Ayes, MPT McLain  
                                  Commissioner Boutros  
                                  Commissioner Host  
                                  Mayor Longe  
                                  Commissioner Haig  
                                  Commissioner Schafer  
                                  Commissioner Baller

Nays, None

The Mayor noted that Messrs. Mando and Sirich would be sworn in at a later date.

**Employee Recognition**

FC Wells stated that he was informed earlier on April 24, 2023 that Birmingham’s ISO rating was raised to a two. He recognized the promotion of Jeff Scaife to Fire Marshal.

FM Scaife briefly spoke and was acknowledged by the Commission.

<b>IV. OPEN TO THE PUBLIC FOR MATTERS NOT ON THE AGENDA</b>
---

<b>V. CONSENT AGENDA</b>
--------------------------

**04-085-23 Consent Agenda**

The following items were pulled from the Consent Agenda:

- Commissioner Haig: Item H – Amendment to Tennis Facility Lease
- Item K – Delinquent Special Assessments/Invoices to the Tax Roll
- MPT McLain:           Item D – Warrant List Dated 04/05/2023

Item M – Temporary Art Installation - Piano in the Park

**MOTION:** Motion by Commissioner Boutros, seconded by MPT McLain:  
To approve the Consent Agenda excluding Items D, H, K, and M.

ROLL CALL VOTE: Ayes, MPT McLain  
Commissioner Boutros  
Commissioner Host  
Mayor Longe  
Commissioner Haig  
Commissioner Schafer  
Commissioner Baller

Nays, None

- A. Resolution to approve the City Commission regular meeting minutes of March 27, 2023.
- B. Resolution to approve the City Commission workshop meeting minutes of April 3, 2023.
- C. Resolution to approve the City Commission regular meeting minutes of April 3, 2023.
- E. Resolution to approve the warrant list, including Automated Clearing House payments, dated April 12, 2023 in the amount of \$633,448.28.
- F. Resolution to approve the warrant list, including Automated Clearing House payments, dated April 19, 2023 in the amount of \$1,190,459.59.
- G. Resolution to approve the purchase of a Tandem-Axle Dump Truck from Wolverine Truck Group, located at 107 S. Groesbeck, Mt. Clemens, MI 48043, under the Rochester Hills Cooperative Agreement, RFP-RH-20-023, in the amount not to exceed \$313,976.00. In addition, to authorize the Mayor and City Clerk to sign the agreement on behalf of the City. Funds for this purchase are available in the FY 2022-2023 Auto Equipment Fund account #661.0-441.006.971.0100.
- I. Resolution to approve an extension of the public services and minor home repair contract with NEXT for the purpose of expending remaining program year 2020-2021 Community Development Block Grant funds for Minor Home Repair Services administered by NEXT through June 30, 2024; and further, to authorize the Mayor and the City Clerk to sign the amendment on behalf of the City.
- J. Resolution to award the 2022-2023 Public Services contract totaling \$10,445.00 for Yard Services and Senior Outreach Services to NEXT under the Community Development Block Grant Program; and further, to authorize the Mayor to sign the contract on behalf of the City.
- L. Resolution WHEREAS, The City Treasurer, in accordance with Chapter 114, Section 114-303, of the city code has reported certain water/sewage accounts, including interest and penalty, unpaid and delinquent on May 1, 2023, and

WHEREAS, Chapter 114, Section 114-303, of the city code provides that these payments shall be carried to the next annual city tax roll.

NOW, THEREFORE, BE IT RESOLVED, that the properties with unpaid and delinquent water/sewage accounts, listed in the Delinquent Water/Sewer Tax Roll, dated April 13, 2023, including interest and penalty, be transferred and reassessed to the 2023 city tax roll and authorization be given to remove from the list any bills paid or a payment plan agreement signed after commission approval.

- N. Resolution to approve the project budget increase for Contract #5-21 (P), 2021 Asphalt Resurfacing Program, by \$382,510.00 to a total budget for Parking Lot No. 5 of \$485,510.00, and approving the appropriation and amendment of the 2022/2023 budget as follows:

Automobile Parking System:

Revenues:

Draw from Fund Balance	514.1-000.000-400.0000	\$382,510.00
------------------------	------------------------	--------------

Expenditures:

Public Improvements	514.1-594.005-981.0100-21.ASPHALT	\$382,510.00
---------------------	-----------------------------------	--------------

- O. Resolution to set the Public Hearing of Necessity for the construction of sidewalk and streetscape improvements adjacent to all properties within the project area on Brown Street, from S. Old Woodward Ave. to Woodward Ave., on Monday, May 8, 2023, at 7:30 P.M.; and

If necessity is determined on May 8, 2023, to meet on Monday, May 22, 2023, at 7:30 P.M., for the purpose of conducting the Public Hearing to Confirm the Assessment Roll for construction of sidewalk and streetscape improvements adjacent to all properties within the project area on Brown Street, from S. Old Woodward Ave. to Woodward Ave.

- P. Resolution to accept the resignation of George Stern from the Greenwood Cemetery Advisory Board, to thank him for his service, and to direct the City Clerk to begin the process of filling the vacancy of this regular board member position with term expiration of July 6, 2024.

- Q. Resolution to accept the resignation of Robert Ziegleman, Chris McLogan and Luke Joseph from the Housing Board of Appeals, to thank them for their service, and to direct the City Clerk to continue to accept applications to fill vacancies on the Housing Board of Appeals.

The City Manager recommended the Commission handle the items removed from the consent agenda after discussing the Proposed Ordinance Amending Chapter 66 – Establishing Tenants Rights for Senior Citizens.

The Commission concurred.

**VI. UNFINISHED BUSINESS**

**04-086-23 Proposed Ordinance Amending Chapter 66 – Establishing Tenants Rights for Senior Citizens**

CA Kucharek presented the item. She and CM Markus answered informational questions from the Commission.

In reply to an inquiry from the Mayor, Oakland County Commissioner (OCC) Charlie Cavell advised the Commission that the two Michigan House bills regarding tenants’ rights have been introduced every year for the last fifteen years.

Commissioner comments were as follows:

- It would be prudent to have some form of renters' protections, and it is also important to ensure that the requirements are not overly burdensome for either landlord or tenant. A landlord-tenant Code of Conduct, in which present protections are listed and mediation is encouraged, might be an appropriate first step before legislation;
  - Landlords could be invited to sign on to such a Code of Conduct, and could be listed as such. Tenants could also share comments regarding violations of the Code of Conduct; and,
- All tenants, regardless of age, should be able to renew their leases unless there is just cause for non-renewal.

### Public Comment

Diane Anderson described some renters' recent difficulties with certain landlords in Birmingham and stated that Michigan is well-known for being lax in its tenant protections.

Steve Tomkowiak, attorney with the Fair Housing Center of Metropolitan Detroit (FHCMD), listed 13 Michigan municipalities that have source of income protection. He stated that, to his knowledge, no litigation has occurred because of source of income protection in Michigan. He said he could provide training and other comments on the matter free-of-charge since the FHCMD is grant-funded. He recommended, in concurrence with Commissioner Host, that tenant protections not be restricted by age, noting that it is illegal in Michigan for landlords to ask a tenant's age.

Dorothy Conrad stated the cost of fighting an eviction would often be prohibitive to renters. She stated she prevailed in her eviction case because of the support of hundreds of community members, and noted that every tenant could not rely on similar levels of advocacy. She noted that her tenant rights' group had not been asked for input on the proposed ordinance changes. She asked that the currently proposed ordinance changes not be approved, that the Commission seek comment from tenants, and that the Commission reformulate the proposed changes based on those conversations.

Mary Williams said, in concurrence with Commissioner Host, that tenant protections should be available to all good tenants.

Jim Gromer, attorney, said limiting auto-renewal and source of income protections to the over 65 groups was proper. He spoke in favor of reaching a balance between landlords' and tenants' interests.

Mike Santi stated he was a landlord to a tenant that remained in her apartment until she passed away at 106 years old. He said there were two sides to the story about landlords.

Jenni Scheid, attorney, said she worked for 20 years with the Michigan Department of Civil Rights (MDCR) and that age restrictions included in the currently proposed ordinance changes would violate Michigan's Elliott-Larsen Civil Rights Act. She recommended the City consult the MDCR for their opinion on the currently proposed ordinance changes.

Sue Chatlin noted that people with disabilities are another group that could be severely impacted by a lack of tenant protections. She asked that tenant protections be extended to all tenants, and not just those over the age of 65.

Mary Ryan Taras said she was disappointed with the narrowness of the proposed ordinance changes. She said Birmingham had an opportunity to present a moderate ordinance that would balance landlord and tenant rights, and that the State could look to for a model for future legislation. She expressed

disappointment that tenants were not asked for input on the proposed ordinance changes. She encouraged the Commission to be brave and to have a meeting for listening to all affected voices on the topic. She said that rights and justice should not be age-limited.

OCC Cavell stated that Oakland County created an Attainable Housing Trust Fund in 2021. He said that any increased housing access, fair housing, and/or protection of renters' rights in the City would enable developers working in Birmingham to access funds from the Attainable Housing Trust Fund, which is permanently funded.

Seeing no further public comment, the Mayor returned the discussion to the Commission.

Commissioner Boutros said he was not ready to vote on the item. He recommended the City solicit more guidance from attorneys who work on these topics and from the MDCR.

The Mayor said there were a minimum of three open issues regarding the matter: the practicality of a Code of Conduct as opposed to an ordinance change, whether an age limit in the ordinance would be prohibited under the Elliott-Larsen Civil Rights Act, and whether the word 'citizen' should be removed.

The Mayor encouraged any interested member of the public to email their opinions on the matter to the City Manager for referral to the Commission.

MPT McLain explained all the research and work that goes into consideration of these matters. She also encouraged residents to reach out, by email, mailed letters, the GovAlert app, or via voicemail that could be transcribed and shared.

**MOTION:** Motion by Commissioner Boutros, seconded by Commissioner Haig:  
To table the proposed ordinance to establish tenants' rights for senior citizens to a later date.

VOICE VOTE: Ayes, MPT McLain  
Commissioner Boutros  
Commissioner Host  
Mayor Longe  
Commissioner Haig  
Commissioner Schafer  
Commissioner Baller

Nays, None

The Mayor thanked everyone for their participation.

**VII. REMOVED FROM CONSENT AGENDA**

**04-087-23 Amendment to Tennis Facility Lease (Item H)**

CM Markus answered informational questions from the Commission. He stated that he believed this represented a recreational asset to the community.

Commissioner Baller concurred with CM Markus, and added that he would be supportive of considering similar recreational opportunities with other operators on small portions of public land.

Commissioner Boutros concurred with the City Manager as well. He said requiring parking would change the operator's considerations.

Commissioner Haig said he would like to know if the tennis operator would be charged market rate. He said not requiring parking in this case was different from other commercial uses that have been before the Commission.

CM Markus explained that this would be a public-private partnership, which is different from the other commercial uses mentioned by Commissioner Haig as potentially precedential. He noted that there would be common parking for all recreational uses. He said there was no shortage of parking during the winter months unless there was a major hockey tournament, and noted that on-street parking was also available.

Commissioner Baller said he estimated that the rate was close to market rate, and noted that the City was receiving a service in return.

**MOTION:** Motion by Commissioner Baller, seconded by Commissioner Schafer:  
To approve the Fourth Amendment to the Tennis Facility Lease with the Birmingham Racquet Club authorizing a second ten (10) year extension to the lease, ending September 30, 2043, in consideration of the Lessee making long-term improvements and maintenance of the tennis facility and offering a resident discount of 20% across all memberships according to Attachment A. Further, to authorize the Mayor and Clerk to sign the agreement upon receipt of the required insurance.

Public Comment

Pam Graham recommended the motion not be approved presently because of concerns around transparency, competitiveness, meeting the programming needs of everyone in the community, the level and prices of services, flexibility, and the measures taken to protect City assets.

CM Markus noted that one of the courts is striped for pickleball, and agreed with Ms. Graham that it helps meet the programming needs of the community.

Jeff Stassen, CEO of the Birmingham Racquet Club, said the goal is to continue to provide first-rate service to Birmingham and the surrounding communities. He said the expense of the maintenance required more time to amortize the costs. He said the goal was to install the new domes in August 2024. He explained how the Racquet Club benefits the community and noted that tennis was a financially difficult sport to provide space for.

In reply to CM Markus, Mr. Stassen confirmed he was not just amortizing for depreciation purposes. He confirmed he was amortizing the cost over the expected life of the facility with the hope that enough revenue could be generated to pay the expenses and generate some profit. He stated that the rates being charged were competitive and were evidenced by the routinely full courts.

Commissioner Baller said he appreciated Ms. Graham's comments, and said it was possible the Parks and Recreation Board should have weighed in on the item. He also offered his support for the motion.

ROLL CALL VOTE: Ayes, MPT McLain  
Commissioner Boutros  
Commissioner Host  
Mayor Longe  
Commissioner Haig

Commissioner Schafer  
Commissioner Baller

Nays, None

**04-088-23 Delinquent Special Assessments/Invoices to the Tax Roll (Item K)**

Commissioner Haig said the City should discourage those who frequently are delinquent on their Special Assessments/Invoices to the Tax Roll from continuing to be so. He noted that previous Commissioner Sherman had made a similar comment when the same item had occurred in years prior.

FD Gerber said he was not sure, beyond the 15% penalty, how to encourage residents to pay their bills on time.

CM Markus noted the issue may have related more to Consent Agenda Item L.

Commissioner Haig said he picked between Consent Agenda Items K and L to make the comment.

**MOTION:** Motion by Commissioner Haig, seconded by Commissioner Boutros:  
To move Consent Agenda Item K as written in the evening's agenda packet.

K. Resolution WHEREAS, the City Treasurer, in accordance with the provisions in the City Code has reported certain special assessments and invoices, including interest and penalty, unpaid and delinquent on May 1, 2023, and

WHEREAS, the City Code provides that these delinquent special assessments and invoices shall be carried to the next annual City tax roll,

NOW THEREFORE BE IT RESOLVED, that the listing of unpaid and delinquent special assessments and invoices, including interest and penalty, be transferred and reassessed to the 2023 City tax roll with an additional 15% penalty and authorization be given to remove from the list any bills paid after commission approval.

ROLL CALL VOTE: Ayes, MPT McLain  
Commissioner Boutros  
Commissioner Host  
Mayor Longe  
Commissioner Haig  
Commissioner Schafer  
Commissioner Baller

Nays, None

**04-089-23 Warrant List Dated 04/05/2023 (Item D)**

MPT McLain noted that the warrant list included payments to the 48th District Court, and informed the public that she would observe every time the City makes a payment to the 48th District Court since concerns have arisen in the past.

**MOTION:** Motion by MPT McLain, seconded by Commissioner Host:  
To approve the warrant list, including Automated Clearing House payments, dated April 5, 2023 in the amount of \$402,708.23.

ROLL CALL VOTE: Ayes, MPT McLain  
Commissioner Boutros  
Commissioner Host  
Mayor Longe  
Commissioner Haig  
Commissioner Schafer  
Commissioner Baller

Nays, None

**04-090-23 Temporary Art Installation - Piano in the Park (Item M)**

MPT McLain said it would be beneficial to provide signage that encourages members of the public to respect the instrument.

CM Markus said he directed Staff to find a way to tether the piano so it could be moved for concerts but not removed from the Park. He said other communities also use outdoor furniture covers for their outdoor pianos.

MPT McLain said she would be happy to donate an outdoor furniture cover for the piano if allowed.

**MOTION:** Motion by MPT McLain, seconded by Commissioner Host:  
To approve the art donation and temporary art installation of a piano to be placed in Shain Park beneath the Markus Pavilion from the middle of May 2023 to the end of November 2023.

ROLL CALL VOTE: Ayes, MPT McLain  
Commissioner Boutros  
Commissioner Host  
Mayor Longe  
Commissioner Haig  
Commissioner Schafer  
Commissioner Baller

Nays, None

**VI. UNFINISHED BUSINESS (Cont.)**

**04-091-23 Public Hearing - to amend Chapter 126 (Zoning), Article 3, Section 3.04, Article 3, Section 3.16, Article 4, Section 4.44 and Article 9, Section 9.02 to provide clear and enforceable outdoor dining standards AND to amend Chapter 98 (Streets, Sidewalks and Other Public Places), Article 2 and Article 3, to add language for outdoor dining facilities on public property**



The Mayor opened the public hearing at 9:42 p.m.

PD Dupuis explained the request to postpone.

Seeing no public comment, the Mayor closed the public hearing at 9:43 p.m.

PD Dupuis answered informational questions from the Commission.

Commissioner Baller said he would like to know the history of, and the reasoning for, the City's dislike of eisenglass when the item returns.

**MOTION:** Motion by Commissioner Boutros:

To postpone consideration of the amendments to Chapter 126 (Zoning), Article 3, Section 3.04, Article 3, Section 3.16, Article 4, Section 4.44 and Article 9, Section 9.02 AND the amendments to Chapter 98 (Streets, Sidewalks and Other Public Places), Article 2 and Article 3, to a date certain of May 22, 2023.

ROLL CALL VOTE: Ayes, MPT McLain  
Commissioner Boutros  
Commissioner Host  
Mayor Longe  
Commissioner Schafer  
Commissioner Baller

Nays, None

Absent, Commissioner Haig

#### **04-092-23 Proposed Ordinance Amending Chapter 26 – Establishing and Regulating Marihuana**

CA Kucharek presented the item. CA Kucharek, CM Markus, and PD Dupuis answered informational questions from the Commission.

In reply to Commissioner Baller, PD Dupuis clarified that there were a few parcels on Woodward between 14 Mile and Lincoln that were inadvertently left off the map despite being an area where marihuana businesses could be located.

Commissioner comments were as follows:

- The content of petitions can be misrepresented, and there would be no recourse on the part of the City vis-a-vis those misrepresentations;
- The marihuana laws at the State level were in part formed in response to the lobbying process;
- Passing a marihuana ordinance preëemptively is a much more prudent step than the other available options; and,
- If additional parks were located in certain areas of the City, it might be impossible to locate a marihuana business in Birmingham that would be compliant with State law.

## Public Comment

Aric Klar of Quality Roots said that Birmingham was home to many people knowledgeable in the marijuana industry and recommended the City seek out expert advice. He said there was likely to be extensive competition to locate a retail marijuana business in the City. He cautioned that the proposed ordinance as presently written would likely result in litigation.

Christie Kelly of Sozo concurred with Mr. Klar that marijuana businesses would demonstrate significant interest in locating in Birmingham. She said the Commission might want to revisit whether one retail location would adequately meet the likely demand. She recommended that the City create an application review panel composed of some of the subject matter experts in the City.

Carol Mastroianni, Executive Director of the Birmingham Bloomfield Community Coalition (BBCC), reviewed: changes in THC content of marijuana products over time, the use of THC-containing products by high schoolers in the BBCC's served communities, the levels self-reported mental health concerns in teens in BBCC's served communities, and the increased link between mental health distress and the use of THC-containing products.

Rob Crosby said he runs a financial services business in downtown Birmingham and posited that business owners in downtown Birmingham would not like having a dispensary close by.

Kelly Michaud of BBCC reviewed: the perception among teens of risk and harm associated with trying marijuana, the perception among teens of access to THC-containing products, the likelihood of marijuana addiction in teens, and the potential links between marijuana use and long-term mental health difficulties.

Dana LaKritz Marcus said her preference would be that no marijuana retail establishments be allowed in the City. She acknowledged that may not be possible, and raised concerns about the appeal of marijuana establishments to children and the impact of marijuana on adolescents' brain development.

Seeing no further public comment, the conversation was returned to the Commission.

Commissioner comments were as follows:

- The City needs to consult some of the subject experts for advice on this process;
- It would be worthwhile for the City Attorney to speak with Keego Harbor, Michigan about their recent experiences with marijuana businesses; and,
- It would be worthwhile for the City Attorney to speak with litigators that specialize in defending municipalities in cases pertaining to marijuana businesses.

In reply to the Mayor, CA Kucharek said she would be happy to speak with a litigator that specializes in defending cities in cases pertaining to marijuana businesses about the proposed ordinance language.

**MOTION:** Motion by MPT McLain, Commissioner Boutros:  
To table consideration of the issue to a future date.

Commissioner Haig expressed concern about there being an influx of potential marijuana business applications based on comments from Mr. Klar.

The Mayor said that was likely to occur regardless of whether the proposed ordinance language was presently passed or not. She said her priority was to pass the most defensible ordinance possible.

Commissioner Host said he was intrigued by the idea of creating more City parks, and said residents would likely appreciate additional parks.

The Mayor noted that the City Manager could consider the feasibility of that option while CA Kucharek also conducts her separate research.

Commissioner Baller agreed the City Manager should explore that option. The Commissioner also requested an updated map inclusive of all possible locations.

In reply to a request for clarification, CA Kucharek said the ordinance would aim to limit the number of available marihuana business licenses in the City. She explained that because aspects of this area of the law are still being decided, she could not guarantee that the ordinance would limit the number of available marihuana business licenses in the City long-term.

The Mayor said it would be better for the City to be proactive.

Commissioner Schafer said it was appropriate to table the conversation since there seemed to be a number of opinions on how the Commission should proceed. She also thanked Ms. Mastroianni and Ms. Michaud for their work on behalf of Birmingham youth.

Public Comment

David Bloom concurred with Commissioner Schafer that more information would help the Commission navigate the available options, including the potential option of creating new parks. He recommended the City create a board to study the options available to the community, and that the board could also serve to review marihuana business applications if the City proceeds with that option.

Ms. Kelly said State marihuana law does not set forth parks as a prohibited use or create a buffer space around parks.

ROLL CALL VOTE:     Ayes,   MPT McLain  
  Commissioner Boutros  
  Commissioner Host  
  Mayor Longe  
  Commissioner Haig  
  Commissioner Schafer  
  Commissioner Baller

Nays,   None

**VIII. NEW BUSINESS**

**04-093-23   Establishment of an Ad Hoc Aging in Place Committee**

ACM Ecker presented the item and answered informational questions from the Commission.

Commissioner comments were as follows:

- It would be appropriate to have someone on the committee who studies demographics and data;
- It might be appropriate to have additional committee members familiar with the needs of the senior community;

- It would be appropriate to have an additional committee member able to write well for the composition of the committee’s action plan;
- It might be worthwhile to increase the number of committee members to nine, from seven; and,
- The committee would have the opportunity to speak with Oakland County and SEMCOG experts on seniors, which would help address the need for demographic data.

ACM Ecker said that Staff tends to prefer committees of seven instead of nine, and noted the Commission has discretion on the committee size.

In reply to Commissioner Baller, the Mayor concurred that Staff could be encouraged to make whatever changes deemed necessary based on the Commission’s comments.

**MOTION:** Motion by Commissioner Haig, MPT McLain:  
To establish the Ad Hoc Aging in Place Committee for a term of 18 months, and to direct staff to advertise for upcoming appointments to this committee; further, once established, to direct staff to facilitate the requested studies and research needed to develop an action plan to improve the health, safety and welfare of senior citizens in Birmingham.

Commissioner Baller said he would support the motion as long as ACM Ecker had the ability to adjust the committee roster based on Commission comments.

Commissioner Haig concurred.

The Mayor noted the committee roster would also be informed by the qualifications of the applicants.

VOICE VOTE: Ayes, MPT McLain  
Commissioner Boutros  
Commissioner Host  
Mayor Longe  
Commissioner Haig  
Commissioner Schafer  
Commissioner Baller

Nays, None

**04-094-23 Public Hearing for 1429 Quarton Road (Parcel # 19-26-203-003) – Lot Division**

The Mayor opened the public hearing at 11:23 p.m.

SP Cowan presented the item.

Jon and Jan Elvekrog, applicants, spoke on behalf of the item.

Public Comment

In reply to Mike Santi, neighbor to the west, SP Cowan stated that further lot splits would be up to the future property owner and would have to be checked against the requirements of the municipal code. He explained how setbacks in the City are calculated.

Mr. Santi said he would not be in favor of further lot splits because it could increase the number of adjacent homes and decrease the green space visible from this home.

Webb Barnes, neighbor to the east, said he was fine with the lot split and just did not want his property taxes to be increased as a result of the lot split.

In reply to Mr. Barnes, CM Markus explained that property taxes are usually based on the value of the property determined from comparable sales. CM Markus said that a lot split of one property would not cause a different property's taxes to increase.

The Mayor noted there were five letters on the matter that were entered into the record, with two in support and three against the requested lot split.

The Mayor closed the public hearing at 11:44 p.m.

Individual Commissioner comments were as follows:

- This lot split would adversely impact the interests of the abutting property owners, which is one of the criteria the ordinance requires the Commission consider. The neighbor to the south asserted this lot split would devalue their property. The lots were probably platted with the depth they have to compensate for being located on Quarton, which is a busy road. The letter writers concerned about drainage on Pilgrim should consider petitioning for improvements to their unimproved street, in order to improve the drainage on the street;
- The lot complies with the ordinance requirements for a lot split, and consequently should be permitted. The left side of Chesterfield between Raynale and Quarton has three lots where one previously was;
- The previous Commission moved lot splits and lot combinations to the Commission so that they could be reviewed on a case-by-case basis to determine what was best for the community. Usually these proposals come to the Commission with more information, including a proposed house design and a developer, which allowed for more certainty in the evaluation;
- The previous Commission only ran into issues with neighbors regarding lot combinations, since they allowed for larger houses. There has not been an issue before with lot splits. There should not be an issue with a requested lot split that otherwise meets all of the ordinance requirements;
- Since neighbors have voiced concerns about the lot split, and the applicant seemed more flexible in their request, it would be better to err on the side of the neighbors;
- The applicant, if interested, could include a covenant for this lot split that would prevent further lot splits so as to not adversely affect Mr. Santi. The lot split otherwise meets the ordinance requirements. Those on Pilgrim should petition to improve their road to address drainage issues; and,
- The argument that the lot split would devalue a neighboring property is subjective. The argument that the increased green space is more pleasing to the neighbors is also not relevant, since each property owner is allowed to do what they wish with their own private property. The lot split seems to meet the overall intent of the ordinance. In addition, if Mr. Santi wanted to preserve the green space on the split lot, he could always purchase the portion without a home.

The Mayor asked Mr. Elvekrog whether he would like the Commission to proceed with a vote or to pend the item.

Mr. Elvekrog asked the Commission to proceed with a vote.

**MOTION:** Motion by Commissioner Boutros, Commissioner Host:

To approve the lot division of 1429 Quarton Road, parcel # 19-26-203-003.

Commissioner Boutros addressed Mr. Santi's concerns, stating that the Commission reviews these requests on a case-by-case basis. He said it was unlikely that a further lot split of the property would be as supported by the Commission. He noted that some further lot splits might not even meet the requirements of the ordinance, given the setbacks and other considerations. Commissioner Boutros said he was moving this motion because he believed the present request was fair and met the ordinance requirements.

At the request of Commissioner Baller, the Mayor asked whether any Commissioners had any ex parte communication with the applicant.

No Commissioners indicated that they had.

Public Comment

Mr. Santi stated that the previous owner of his lot had pursued a lot split which was denied. He asked the Commission to research why the split of his lot was denied. He said the potential approval of this motion, in light of the previously denied split of his lot, was unfair.

ROLL CALL VOTE:     Ayes,   Commissioner Boutros  
  Commissioner Host  
  Commissioner Haig  
  Commissioner Schafer

                                  Nays,   MPT McLain  
  Mayor Longe  
  Commissioner Baller

**04-095-23   Proposed Ordinance Amending Chapter 2 – Changes to the Ethics Ordinance**

CC Bingham presented the item.

**MOTION:**                    Motion by Commissioner Baller, Commissioner Boutros:  
To adopt the ordinance amendments as recommended by the Board of Ethics and to further direct the City Clerk to notice the two available alternate Ethics Board member positions and begin the process of filling these vacancies.

Public Comment

Mr. Bloom said the ordinance required further revisions, including a way to address the conduct of officials outside of their official duties, a way for Commissioners to both engage in advocacy and to be fair and impartial where appropriate, and expanding the Ethics Board to five people plus two alternates.

ROLL CALL VOTE:     Ayes,   Commissioner Boutros  
  Commissioner Host  
  Commissioner Haig  
  Commissioner Schafer  
  MPT McLain  
  Mayor Longe  
  Commissioner Baller

Nays, None

**Commission Items for Future Discussion**

**04-096-23 Special Assessments for Funding Police and Fire Operations**

**MOTION:** Motion by Commissioner Baller, Commissioner Host:  
To have further discussion about how some communities use special assessments to fund Police and Fire operations and whether that would be an appropriate funding mechanism for Birmingham to explore.

VOICE VOTE: Ayes, Commissioner Host  
Commissioner Baller

Nays, Commissioner Schafer  
MPT McLain  
Mayor Longe  
Commissioner Boutros  
Commissioner Haig

**Commission Discussion On Items From A Prior Meeting**

No items were discussed.

**04-097-23 Request for Closed Session Under MCL § 15.268 Sec. 8(d) of the Open Meetings Act and MCL § 15.268 Sec. 8(h)**

CA Kucharek summarized the item.

**MOTION:** Motion by Commissioner Host, Commissioner Baller:  
To meet in closed session to discuss the potential purchase of land pursuant to MCL § 15.268 Sec. 8(d) of the Open Meetings Act and pursuant to MCL § 15.268 Sec. 8(h) to discuss a written attorney client privileged communication.

ROLL CALL VOTE: Ayes, Commissioner Host  
Commissioner Baller  
Commissioner Schafer  
MPT McLain  
Mayor Longe  
Commissioner Boutros  
Commissioner Haig

Nays, None

The Commission went into closed session at 12:40 a.m.

The Commission returned from closed session at 1:23 a.m.

**IX. COMMUNICATIONS**

**X. REPORTS**

- A. Commissioner Reports
  - 1. Notice of Intention to Appoint to the Historic District Study Committee

- 2. Notice of Intention to Appoint to the Greenwood Cemetery Advisory Board
  - 3. Notice of Intention to Appoint to the Martha Baldwin Park Board
  - 4. Notice of Intention to Appoint to the Board of Ethics
- B. Commissioner Comments

Commissioner Host read a statement explaining his concerns regarding the revised Code of Conduct and provided a copy of the statement to the City Clerk to receive and file.

Commissioner Baller addressed an item in the City Manager’s Report. He clarified that he had no interest in having the City involved in the formation or administration of a Foundation. He described further topics around event creation and administration that he was interested in exploring and discussing.

Commissioner Baller then praised the Commission and the City administration. He asked the Commission to read the budget thoroughly in advance of the upcoming Budget Hearing and to raise questions and concerns.

MPT McLain asked that the City develop a one-page summary of the Ad Hoc Unimproved Streets Study Committee’s report in order to better communicate the information to residents. She said there was a lot of resident interest in the topic.

- C. Advisory Boards, Committees, Commissions’ Reports and Agendas
- D. Legislation
- E. City Staff
  - 1. City Manager’s Report

CM Markus reviewed his report. He said Staff would schedule a workshop for the Commission to discuss the Code of Conduct.

- 2. Code of Conduct

INFORMATION ONLY

**XI. ADJOURN**

Mayor Longe adjourned the meeting at 1:23 a.m.

Alexandria Bingham, City Clerk



Laura Eichenhorn, City Transcriptionist



# City of Birmingham

## Warrant List Dated 04/26/2023

Meeting of 05/08/2023

Check Number	Early Release	Vendor #	Vendor	Amount
<u>PAPER CHECK</u>				
291740		BDREFUND	ALBERT D THOMAS INC	500.00
291741		009372	ALLIED FIRE SALES & SERVICE	4,384.91
291742		009126	AMAZON CAPITAL SERVICES INC	70.24
291743		BDREFUND	APEX ROOFING INC	100.00
291744		000500	ARTECH PRINTING INC	65.00
291745	*	006759	AT&T	375.00
291746	*	006759	AT&T	318.03
291747	*	006759	AT&T	155.61
291748	*	003703	AT&T MOBILITY	1,187.84
291749		BDREFUND	B-DRY SYSTEM OF MICHIGAN INC	100.00
291750		BDREFUND	Ball Construction	300.00
291751		BDREFUND	BAZAJ, ADRIAN	100.00
291752	*	002429	BIRMINGHAM BLOOMFIELD CHAMBER	2,500.00
291753	*	000524	BIRMINGHAM LOCKSMITH INC	464.00
291754		008355	BIRMINGHAM PUBLIC SCHOOLS	32.60
291755		BDREFUND	BLACK & VEATCH	200.00
291756	*	002982	BLOOMFIELD TWP FIRE DEPT	139.86
291757	*	005706	DAVID A. BOUTETTE	200.00
291758		BDREFUND	BREWER ROOFING	100.00
291759		006966	BRIDGESTONE GOLF, INC	501.74
291760		BDREFUND	BRIGHT HOME RENOVATION	200.00
291761		006520	BS&A SOFTWARE, INC	1,756.00
291761	*	006520	BS&A SOFTWARE, INC	13,225.00
291762	*	009078	CANON SOLUTIONS AMERICA INC	2,677.54
291763		004269	CENTER POINT LARGE PRINT	57.34
291764		BDREFUND	CLARK BASEMENT WATERPROOFING/D	100.00
291765	*	008006	CLEAR RATE COMMUNICATIONS, INC	1,615.24
291766		BDREFUND	COMPLETE CONTRACTING SERVICES, LLC	100.00
291767	*	000627	CONSUMERS ENERGY	1,579.57
291768		008582	CORE & MAIN LP	1,178.88
291769	*	008801	COSTAR REALTY INFORMATION, INC	1,836.00
291770	*	009549	DANIEL CRUMP DBA	1,850.00
291771		009529	DAVEY RESOURCE GROUP, INC.	2,275.00
291772		MISC	DAVID BRUECKMAN	180.00
291773		009643	DEFENSE TECHNOLOGY LLC	650.00
291774		MISC	DENNIS DEMBIEC	1,710.00
291775		BDREFUND	DJLL1 LLC	2,000.00
291776	*	000190	DOWNRIVER REFRIGERATION	7.80
291777	*	000179	DTE ENERGY	194.16
291778	*	000180	DTE ENERGY	9,953.46
291779	*	007045	DYNAMIC BRANDS	140.00
291780		009575	EAGLE SECURITY & LIFE SAFETY, INC	4,572.00
291781	*	000995	EQUATUR	1,170.15

**City of Birmingham**  
**Warrant List Dated 04/26/2023**

Meeting of 05/08/2023

Check Number	Early Release	Vendor #	Vendor	Amount
291782		MISC	ERIKA MCCLOSKEY	14.95
291783		000585	FARMINGTON COMM. LIBRARY	4,334.36
291784		001223	FAST SIGNS	277.00
291785	*	000936	FEDEX	16.83
291786		007136	FERGUSON ENTERPRISES, INC.	593.33
291787	*	007366	FIRST ADVANTAGE OCCUPATIONAL CORP	44.23
291788		BDREFUND	FORTRESS HOME IMPROVEMENT	100.00
291789		BDREFUND	FOUNDATION SYSTEMS OF MICHIGAN INC.	100.00
291790	*	009313	FRANCE MEDIA INC	1,500.00
291791		BDREFUND	FULLERTON ENGINEERING	200.00
291792	*	004604	GORDON FOOD	2,223.55
291793	*	006666	GRID 4 COMMUNICATIONS INC.	225.04
291794		000249	GUARDIAN ALARM	279.60
291795		006346	HARRELL'S LLC	6,594.00
291796		003132	HASTINGS AIR-ENERGY CONTROL INC	875.00
291797		BDREFUND	HATHAWAY, JOSEPH EDWARD	1,000.00
291798		009527	HFF MICHIGAN HOLDINGS INC	263.99
291799		BDREFUND	HILLAN HOMES, INC	1,400.00
291800		BDREFUND	HM HOMES LLC	1,400.00
291801	*	001956	HOME DEPOT CREDIT SERVICES	466.80
291802	*	006801	HOWLEY AGENCY SALES	227.68
291803	*	009500	IBM CORPORATION	2,976.00
291804		001090	INGRAM LIBRARY SERVICES	5,284.69
291806		BDREFUND	J.M. OLSON	500.00
291807		BDREFUND	JOSEPH J GILLETTE	1,000.00
291808		BDREFUND	K & K COMPANIES	1,000.00
291809		BDREFUND	KAMEN, ERIC	500.00
291810	*	009238	KATHERINE ROSE COLLINS	599.29
291811		BDREFUND	KELLETT DEVELOPMENT LLC	100.00
291812		BDREFUND	KEVIN B FANDOZZI ANN M EVENSON	100.00
291813		004088	KGM DISTRIBUTORS INC	151.00
291814	*	000362	KROGER COMPANY	74.85
291815		MISC	LAURA C PHILLIPS	19.99
291816		009375	LITHIA MOTORS, INC SUPPORT SERVICES	78.43
291817	*	009350	LITTLE GUIDE LLC	500.00
291818		BDREFUND	LOCHIRCO CUSTOM HOMES	100.00
291819		BDREFUND	LUXE HOMES DESIGN BUILD LLC	1,913.18
291820		BDREFUND	MAPLEWOOD EQUITIES LLC	200.00
291821	*	MISC	MARC GARRISON	20.00
291822		BDREFUND	MASTERWORKS CONTRACTING LLC	500.00
291823	*	MISC	MATT DEROUSSE	226.45
291824	*	000369	MCFI	2,732.50
291825		MISC	MICHAEL CASEY	14.99

**City of Birmingham**  
**Warrant List Dated 04/26/2023**

Meeting of 05/08/2023

Check Number	Early Release	Vendor #	Vendor	Amount
291826	*	001228	STATE OF MICHIGAN-BOILERS	120.00
291827		006349	MIDWEST COLLABORATIVE	100.00
291828		BDREFUND	MIDWEST EXCAVATION LLC	542.30
291829		000230	MIKE SAVOIE CHEVROLET INC	1,729.70
291830	*	005634	GINA MOODY	288.00
291831		BDREFUND	MR ROOF HOLDING CO LLC	100.00
291832		BDREFUND	MT EVEREST MAINTENANCE	200.00
291833		BDREFUND	MULLIGAN CONSTRUCTION	100.00
291834		002010	MULTISTATE TRANSMISSIONS	3,961.27
291835		BDREFUND	N A MANS & SONS INC	500.00
291836		MISC	NARUDEE PHONGADULYASOOK	15.99
291837		MISC	NATALIE FORD	22.49
291838	*	008424	NATIONAL MAIN STREET	375.00
291839		008336	NBS COMMERCIAL INTERIORS	792.00
291840		BDREFUND	NCS CONSTRUCTION SERVICES LLC	1,000.00
291841	*	004827	NICK'S MAINTENANCE SERVICE	10,700.00
291842		BDREFUND	OAKES ROOFING SIDING & WINDOWS INC	100.00
291843	*	008519	OAKLAND COUNTY MOMS	450.00
291844	*	004370	OCCUPATIONAL HEALTH CENTERS	563.00
291845	*	009478	ODP BUSINESS SOLUTIONS, LLC	162.93
291846		BDREFUND	OVERLAND CONTRACTING INC.	200.00
291847	*	MISC	PAMELA GERBER	40.00
291848	*	MISC	PATRICK OBRIEN	40.00
291849		BDREFUND	PELLA WINDOWS & DOORS, INC.	500.00
291850	*	009614	PROGRESSIVE PLUMBING SUPPLY CO	34.36
291851		006625	PTS COMMUNICATIONS, INC	85.80
291852		BDREFUND	PYTIK DESIGN & BUILD	500.00
291853		002566	REYNOLDS WATER	22.15
291854		BDREFUND	ROBERT F RUNCO LODIA A RUNCO	1,560.00
291855	*	009639	ROBERT G WYLIN II	2,300.00
291856		BDREFUND	ROBERT J SOWLES	200.00
291857		BDREFUND	ROMA CEMENT CO INC	100.00
291858	*	004727	MARGARET SCHMALTZ	200.00
291859		009601	SCNS INC	159.20
291860	*	009282	SEEN MEDIA GROUP	15,450.00
291861		BDREFUND	SHEARS CONSTRUCTION	110.00
291862		BDREFUND	SIGNGRAPHIX, INC.	600.00
291863		009641	SINCLAIR RECREATION, LLC	2,255.00
291864		007907	SP+ CORPORATION	8,478.00
291865		000260	SPARTAN DISTRIBUTORS INC	1,949.40
291866	*	009338	SPECIALIZED STEELWORKS, LLC	3,040.00
291867	*	001716	SPEEDY TEES INC	816.00
291868	*	009201	STEPHEN SHUKWIT	1,200.00

# City of Birmingham

## Warrant List Dated 04/26/2023

Meeting of 05/08/2023

Check Number	Early Release	Vendor #	Vendor	Amount
291869		004544	STRYKER SALES CORPORATION	331.50
291870		005863	SUCCESS COMMUNICATIONS, INC.	845.00
291871		009618	SUPERIOR DIESEAL REPAIR INC	525.00
291872	*	007781	SWNAK MOTION PICTURES, INC	1,440.00
291873		BDREFUND	TECHHOME BUILDING CO., LLC	6,057.00
291874		BDREFUND	THOMAS PLUMBING & HEATING	1,000.00
291875		BDREFUND	THOMAS SEBOLD & ASSOCIATES, IN	5,630.00
291876	*	003173	TIFFANY FLORIST	96.90
291877	*	005449	UNEMPLOYMENT INS AGENCY	190.55
291878	*	001279	US FIGURE SKATING ASSOC.	520.00
291879		007226	VALLEY CITY LINEN, INC	182.48
291880	*	000293	VAN DYKE GAS CO.	112.36
291881	*	000158	VERIZON WIRELESS	98.12
291882	*	000158	VERIZON WIRELESS	151.22
291883	*	000158	VERIZON WIRELESS	316.37
291884		BDREFUND	VICTOR TALIA ARCHITECTURE LLC	300.00
291885		006491	VILLAGE AUTOMOTIVE INC	122.10
291886	*	009637	VISIT DETROIT	247.90
291887		000299	WEINGARTZ SUPPLY CO.	26.94
291888		BDREFUND	WIRELESS FACILITIES INC	100.00
291889		007620	WJE-WISS, JANNEY, ELSTNER ASSOC.INC	86,950.00
291890		BDREFUND	WORK COMPANY LLC	500.00
291891		BDREFUND	YOUNG HO LEE	100.00

SUBTOTAL PAPER CHECK \$269,056.73

ACH TRANSACTION

39	*	009126	AMAZON CAPITAL SERVICES INC	26.88
40	*	009126	AMAZON CAPITAL SERVICES INC	38.24
7857	*	009323	ALEXANDRIA BINGHAM	231.93
7858		009126	AMAZON CAPITAL SERVICES INC	(88.99)
7858	*	009126	AMAZON CAPITAL SERVICES INC	45.98
7859	*	009126	AMAZON CAPITAL SERVICES INC	165.87
7860	*	009126	AMAZON CAPITAL SERVICES INC	119.75
7861		009126	AMAZON CAPITAL SERVICES INC	197.46
7862		009126	AMAZON CAPITAL SERVICES INC	20.98
7863		009126	AMAZON CAPITAL SERVICES INC	69.99
7864	*	009126	AMAZON CAPITAL SERVICES INC	31.48
7865		009126	AMAZON CAPITAL SERVICES INC	107.99
7866		009126	AMAZON CAPITAL SERVICES INC	96.62
7867		009126	AMAZON CAPITAL SERVICES INC	123.27
7868		009126	AMAZON CAPITAL SERVICES INC	44.56
7869		009126	AMAZON CAPITAL SERVICES INC	80.78
7870		009126	AMAZON CAPITAL SERVICES INC	12.50
7871		009126	AMAZON CAPITAL SERVICES INC	82.00

**City of Birmingham**  
**Warrant List Dated 04/26/2023**

Meeting of 05/08/2023

Check Number	Early Release	Vendor #	Vendor	Amount
7872	*	009126	AMAZON CAPITAL SERVICES INC	44.19
7873	*	000517	BEIER HOWLETT P.C.	792.00
7874	*	007345	BEVERLY HILLS ACE	7.00
7875	*	003282	LISA MARIE BRADLEY	392.00
7876	*	008983	BRENNA SANDLES	761.00
7877		008545	JAIMI BROOK	16.50
7878		007875	CANFIELD EQUIPMENT SERVICE INC.	5,010.00
7879	*	009352	CHRISTINA WOODS	220.25
7880		000605	CINTAS CORPORATION	171.06
7881		000605	CINTAS CORPORATION	227.60
7882		003633	CLARKE MOSQUITO CONTROL PRODUCT INC	11,616.00
7883		002668	CONTRACTORS CLOTHING CO	314.95
7884	*	007359	DETROIT CHEMICAL & PAPER SUPPLY	26.52
7885	*	000565	DORNBOS SIGN & SAFETY INC	409.32
7886		000196	EJ USA, INC.	3,878.12
7887	*	009250	ERIKA BASSETT	16.50
7888	*	000213	FIRE DEFENSE EQUIP CO INC	1,084.08
7889	*	001230	FIRE SYSTEMS OF MICHIGAN LLC	199.50
7890	*	007314	FLEIS AND VANDENBRINK ENG. INC	2,424.75
7891		000217	FOUR SEASON RADIATOR SERVICE INC	512.20
7892	*	000243	GRAINGER	266.30
7893	*	001672	HAYES PRECISION INC	255.00
7894		009635	ICLEI	1,200.00
7895		000261	J.H. HART URBAN FORESTRY	21,281.50
7896	*	002576	JAX KAR WASH	304.00
7897	*	009249	JCC CREATIVE LLC	500.00
7898	*	003458	JOE'S AUTO PARTS, INC.	313.83
7899	*	004085	KONE INC	2,086.45
7900	*	005876	KROPF MECHANICAL SERVICE COMPANY	4,116.64
7901		002013	MIDWEST TAPE	722.91
7902	*	009242	MILES PARTNERSHIP LLLP	1,107.50
7903	*	006359	NYE UNIFORM COMPANY	562.50
7904	*	002767	OSCAR W. LARSON CO.	502.50
7905	*	001753	PEPSI COLA	523.72
7906	*	000478	ROAD COMM FOR OAKLAND CO	2,750.03
7907	*	001181	ROSE PEST SOLUTIONS	153.00
7908	*	003785	SIGNS-N-DESIGNS INC	1,015.00
7909	*	007899	NICHOLAS SLANDA	25.00
7910		000254	SOCRRA	73,144.00
7911	*	004692	TRANSPARENT WINDOW CLEANING	6,740.00
7912		008711	VOLVIK USA	1,235.55
7913		002088	WM. CROOK FIRE PROTECTION CO.	2,492.00
7914		009592	YOURMEMBERSHIP.COM, INC	249.00

**City of Birmingham**  
**Warrant List Dated 04/26/2023**

Meeting of 05/08/2023

Check Number	Early Release	Vendor #	Vendor	Amount
			SUBTOTAL ACH TRANSACTION	\$151,077.26
			GRAND TOTAL	<u>\$420,133.99</u>

All bills, invoices and other evidences of claim have been audited and approved for payment.



Mark Gerber  
Finance Director/ Treasurer

\*-Indicates checks released in advance and prior to commission approval in order to avoid penalty or to meet contractual agreement/obligation.

**City of Birmingham**  
**Warrant List Dated 05/04/2023**

Meeting of 05/08/2023

Check Number	Early Release	Vendor #	Vendor	Amount
<u>PAPER CHECK</u>				
291892		006638	ACTION MAT & TOWEL RENTAL, INC	70.72
291893	*	008106	ACUSHNET COMPANY	200.23
291894		MISC	ALEXANDER MICHAEL PUDVAY	60.00
291895		009126	AMAZON CAPITAL SERVICES INC	30.33
291896	*	006759	AT&T	291.10
291897	*	006759	AT&T	721.33
291898	*	006759	AT&T	3,037.39
291899		009609	BALIAN LEGAL, PLC	600.00
291900	*	UBREFUND	BECKETT, ROBERT A	203.16
291901	*	MISC	BRENDEN MEREDITH	20.54
291902	*	006953	JACQUELYN BRITO	21.93
291903	*	009078	CANON SOLUTIONS AMERICA INC	163.20
291904	*	003904	CAPITAL ONE BANK	909.16
291905		008959	CASS COLLISION CLAWSON, INC	2,173.62
291906	*	000444	CDW GOVERNMENT INC	4,456.00
291907	*	009137	CGS, INC	1,005.00
291908		002234	CMP DISTRIBUTORS INC	9,095.00
291909	*	007774	COMCAST BUSINESS	1,268.94
291910	*	000627	CONSUMERS ENERGY	7,528.04
291911		008512	COOL THREADS EMBROIDERY	1,860.50
291912	*	009557	ZECO, LLC	2,709.00
291913		000575	DEMCO, INC	188.87
291914		009130	DOG WASTE DEPOT	1,305.62
291915	*	000179	DTE ENERGY	6,487.45
291916	*	000179	DTE ENERGY	189.90
291917	*	000179	DTE ENERGY	5,559.01
291918	*	000179	DTE ENERGY	480.02
291919	*	000179	DTE ENERGY	1,987.76
291920	*	000179	DTE ENERGY	44.25
291921	*	000179	DTE ENERGY	338.40
291922	*	000179	DTE ENERGY	6,999.79
291923	*	000179	DTE ENERGY	2,068.56
291924	*	000179	DTE ENERGY	3,549.37
291925	*	000179	DTE ENERGY	14.89
291926	*	000179	DTE ENERGY	1,924.43
291927	*	000179	DTE ENERGY	42.13
291928	*	000179	DTE ENERGY	15.71
291929	*	000179	DTE ENERGY	29.62
291930	*	000179	DTE ENERGY	123.79
291931	*	000179	DTE ENERGY	26.58
291932	*	000179	DTE ENERGY	42.34
291933	*	000179	DTE ENERGY	142.00

**City of Birmingham**  
**Warrant List Dated 05/04/2023**

Meeting of 05/08/2023

Check Number	Early Release	Vendor #	Vendor	Amount
291934		000179	DTE ENERGY	14.89
291935	*	MISC	EASTERN MICHIGAN UNIVERSITY	44.95
291936		008164	GARY EISELE	58.75
291937		009620	CITY OF FARMINGTON HILLS	350.00
291938	*	001223	FAST SIGNS	175.75
291939	*	MISC	FUNTASTIC FACES	325.00
291940		009648	GLOCK PROFESSIONAL, INC	500.00
291941	*	004604	GORDON FOOD	265.12
291942	*	009275	GREAT LAKES COCA-COLA DISTRIBUTION	743.50
291943	*	008007	GREAT LAKES WATER AUTHORITY	8,180.30
291944		001531	GUNNERS METER & PARTS INC	3,326.00
291945		007458	HERITAGE - CRYSTAL CLEAN, LLC	2,868.94
291946	*	001956	HOME DEPOT CREDIT SERVICES	1,548.97
291947	*	007211	HOME DEPOT CREDIT SERVICES	239.00
291948		001090	INGRAM LIBRARY SERVICES	1,647.13
291949	*	009401	IRENE S WASSEL	300.00
291950	*	MISC	JOHN MANDICH	346.00
291951	*	MISC	JUDITH SIEGEL-ORR	6.00
291952		MISC	JUSTIN BURRIS	8.32
291953	*	009403	JUSTIN ZAYID	600.00
291954	*	002630	KEATON PUBLICATIONS GROUP LLC	1,250.00
291955	*	000362	KROGER COMPANY	73.88
291956	*	009386	LAW OFFICE OF BRIAN P. FENECH	2,170.00
291957	*	009388	LAW OFFICE OF PATRICK G. GAGNIUK	600.00
291958		000797	THE LIBRARY NETWORK	624.00
291959		002207	MICHIGAN AUTOMATIC SPRINKLER, INC.	9,644.00
291960		MISC	MICHIGAN AUTOMATIC SPRINKLERS	1,513.00
291961	*	001677	STATE OF MICHIGAN-ELEVATOR	195.00
291962	*	008687	NORTH BREATHING AIR, LLC	640.00
291963		009461	OAKLAND COUNTY MUTUAL AID ASSOCIATI	1,215.00
291964	*	009478	ODP BUSINESS SOLUTIONS, LLC	380.46
291965		003881	ORKIN PEST CONTROL	6,045.00
291966		001325	P.K. CONTRACTING INC	26,250.00
291967		009649	PAGE, WOLFBERG& WIRTH, LLC	3,390.39
291968	*	000801	POSTMASTER	290.00
291969	*	000801	POSTMASTER	290.00
291970		004137	R & R FIRE TRUCK REPAIR INC	808.25
291971	*	008342	RAIN MASTER CONTROL SYSTEMS	38.85
291972		007252	RAY WIEGAND'S NURSERY INC.	367.00
291973	*	MISC	RYAN KATZ	99.96
291974	*	002806	SAM'S CLUB/SYNCHRONY BANK	125.17
291975	*	MISC	SANFORD STONE	34.00
291976		009009	SIGNATURE CLEANING LLC	225.00



# City of Birmingham

## Warrant List Dated 05/04/2023

Meeting of 05/08/2023

Check Number	Early Release	Vendor #	Vendor	Amount
291976	*	009009	SIGNATURE CLEANING LLC	4,937.99
291977	*	008073	SITEONE LANDSCAPE SUPPLY, INC	56.64
291978		009325	SMITH'S WATERPROOFING LLC	69,071.78
291979		000260	SPARTAN DISTRIBUTORS INC	39,136.30
291979	*	000260	SPARTAN DISTRIBUTORS INC	41,060.76
291980		008694	TIGERPRESS ADMINISTRATION	1,470.00
291981	*	MISC	TODD BORSE	18.37
291982	*	004379	TURNER SANITATION, INC	1,010.00
291983		005806	ULINE	102.93
291984	*	000293	VAN DYKE GAS CO.	140.45
291985	*	000158	VERIZON WIRELESS	1,471.77
291986	*	000158	VERIZON WIRELESS	850.44
291987	*	000158	VERIZON WIRELESS	49.06
291988	*	000158	VERIZON WIRELESS	147.18
291989		001490	WEST SHORE FIRE INC	403.75
291990		007620	WJE-WISS, JANNEY, ELSTNER ASSOC.INC	36,750.00
SUBTOTAL PAPER CHECK				\$342,480.68

ACH TRANSACTION

7918	*	008649	ROBERT ABRAHAM JR.	958.00
7919		009126	AMAZON CAPITAL SERVICES INC	49.48
7920	*	009126	AMAZON CAPITAL SERVICES INC	14.57
7921		009126	AMAZON CAPITAL SERVICES INC	50.22
7922		009126	AMAZON CAPITAL SERVICES INC	125.12
7923		009126	AMAZON CAPITAL SERVICES INC	69.99
7924		009126	AMAZON CAPITAL SERVICES INC	53.74
7925		009126	AMAZON CAPITAL SERVICES INC	62.40
7926		009126	AMAZON CAPITAL SERVICES INC	9.96
7927		009126	AMAZON CAPITAL SERVICES INC	35.76
7928		009126	AMAZON CAPITAL SERVICES INC	30.93
7929	*	009126	AMAZON CAPITAL SERVICES INC	100.79
7930		009126	AMAZON CAPITAL SERVICES INC	194.00
7931		009126	AMAZON CAPITAL SERVICES INC	32.39
7932	*	009126	AMAZON CAPITAL SERVICES INC	58.42
7933	*	009126	AMAZON CAPITAL SERVICES INC	72.58
7934	*	009126	AMAZON CAPITAL SERVICES INC	74.97
7935	*	008655	ANGELO IAFRATE CONSTRUCTION	148,799.36
7936	*	009383	BATTI LAW PLLC	1,280.00
7937		000518	BELL EQUIPMENT COMPANY	9,346.20
7937	*	000518	BELL EQUIPMENT COMPANY	(265.28)
7938	*	007345	BEVERLY HILLS ACE	225.37
7939	*	009396	CECILIA QUIRINDONGO BAUNSOE	300.00
7940	*	009122	CLAIRE CHUNG	736.00
7941		000605	CINTAS CORPORATION	171.06

**City of Birmingham**  
**Warrant List Dated 05/04/2023**

Meeting of 05/08/2023

Check Number	Early Release	Vendor #	Vendor	Amount
7942		000605	CINTAS CORPORATION	72.40
7943	*	000605	CINTAS CORPORATION	129.15
7944	*	009540	CIVICPLUS, LLC	350.00
7945	*	008044	CLUB PROPHET	2,081.74
7946		002668	CONTRACTORS CLOTHING CO	209.21
7947		001367	CONTRACTORS CONNECTION INC	69.35
7948	*	006999	CHRISTOPHER DEMAN	1,586.50
7949	*	000565	DORNBOS SIGN & SAFETY INC	378.80
7950	*	000995	EQUATURE	3,167.46
7951	*	009449	BRYAN GRULKE	42.97
7952		000331	HUBBELL ROTH & CLARK INC	2,942.05
7953	*	009390	IDUMESARO LAW FIRM, PLLC	600.00
7954	*	008851	INSIGHT INVESTMENT	6,143.76
7955		009249	JCC CREATIVE LLC	450.00
7956		009298	JCR SUPPLY INC	496.22
7957	*	003458	JOE'S AUTO PARTS, INC.	932.82
7958	*	009392	LAMB LEGAL CONSULTING SERVICES	300.00
7959	*	009385	LAW OFFICE OF MICHAEL J. DICK	1,660.00
7960		005550	LEE & ASSOCIATES CO., INC.	7,680.00
7961	*	009398	MARCIA C ROSS PC	1,400.00
7962	*	009370	MICHAEL SIMON	343.00
7963		002013	MIDWEST TAPE	585.34
7964		000462	MOTOR CITY INDUSTRIAL	1,740.34
7965		001194	NELSON BROTHERS SEWER	654.00
7966		007755	NETWORK SERVICES COMPANY	903.00
7967	*	007856	NEXT	654.00
7968		001864	NOWAK & FRAUS ENGINEERS	1,345.00
7969	*	006359	NYE UNIFORM COMPANY	486.00
7970	*	009395	ORLANDO LAW PRACTICE PC	930.00
7971	*	003963	DAVID PAPANDREA	750.00
7972		002852	QMI GROUP INC	135.00
7973	*	009397	RABAA PLLC	500.00
7974	*	005344	RESERVE ACCOUNT	8,000.00
7975	*	003554	RKA PETROLEUM	17,473.95
7976	*	001181	ROSE PEST SOLUTIONS	79.00
7977		000273	TERMINAL SUPPLY CO.	31.20
7978	*	009254	THOMAS M MARKUS	570.00
7979	*	002037	TOTAL ARMORED CAR SERVICE, INC.	281.45
7980	*	002088	WM. CROOK FIRE PROTECTION CO.	1,950.00
7981	*	009379	YELLOW DOOR LAW	4,566.00
SUBTOTAL ACH TRANSACTION				\$235,255.74

**City of Birmingham**  
**Warrant List Dated 05/04/2023**

Meeting of 05/08/2023

Check Number	Early Release	Vendor #	Vendor	Amount
GRAND TOTAL				\$577,736.42

All bills, invoices and other evidences of claim have been audited and approved for payment.



Mark Gerber  
Finance Director/ Treasurer

\*-Indicates checks released in advance and prior to commission approval in order to avoid penalty or to meet contractual agreement/obligation.



## MEMORANDUM

Planning Division

DATE: May 8, 2023

TO: Thomas M. Markus, City Manager

FROM: Brooks Cowan, Senior Planner

APPROVED: Nicholas Dupuis, Planning Director

SUBJECT: Set a Public Hearing for a Lot Combination of 36877 Woodward Ave – Gasow Veterinary Clinic, Parcels #19-25-101-008, 19-25-101-009, 19-25-101-010, and 19-25-101-011.

---

### INTRODUCTION:

The property known as 36877 Woodward Ave – Gasow Veterinary Clinic – has operated on four separate parcels since the 1960’s. The subject lots are located on the west side of Woodward Ave, just south of Quarton Road. The current veterinary building exists on two of southernmost parcels while the northern parking lot exists on the northernmost parcels. The applicant is applying to combine the four parcels into one in order to construct a new veterinary clinic building.

### BACKGROUND:

On July 25, 2022 ([Agenda](#) – [Minutes](#)), the City Commission approved a Special Land Use Permit, Final Site Plan and Design Review application for 36877 Woodward – Gasow – to permit the applicant to demolish the existing 1-story building and parking lot and construct a new 2-story veterinary clinic and associated parking/site improvements. The application was approved with the condition that the applicant obtain lot combination approval from the City Commission.

The Combination of Land Parcels Ordinance (Chapter 102, Section 102-83) requires that the following standards be met for approval of a lot combination.

- (1) *The Combination will result in lots or parcels of land consistent with the character of the area where the property is located, Chapter 126 of this Code for the zone district in which the property is located, and all applicable master land use plans.*

The subject properties are zoned TZ-3 with vacant lots located to the north and the west. A DTE substation is located to the south and there are single family residential homes to the southwest. To the east is Bloomfield Hills with Eddie Merlot’s restaurant and an office building. The property was zoned TZ-3 as a transition zone where Woodward Ave commercial properties abut single family residential sites. The single story veterinary

clinic with adequate parking and newly proposed screen wall appears to blend with the character of the area.

In regards to zoning, the proposed building was approved by the Planning Board on June 8<sup>th</sup>, 2022 ([Agenda](#) – [Minutes](#)). The applicant was required to verify certain design elements be met including proper screening, lighting, and signage. Such elements will be verified administratively before the applicant may obtain their building permit.

**Accordingly, the lot combination proposal meets the requirements of #1.**

- (2) *All residential lots formed as a result of a combination shall be a maximum width of no more than twice the average lot width of all lots in the same zone district within 300 feet on the same street.*

**This standard only applies to single family residential zones. The proposed combination is zoned for mixed use, commercial and multi-family residential, therefore this requirement is not applicable.**

- (3) *All residential lots formed as a result of a combination shall be a maximum area of no more than twice the average lot area of all lots in the same zone district within 300 feet on the same street.*

**This standard only applies to single family residential zones. The proposed combination is zoned for mixed use, commercial and multi-family residential, therefore this requirement is not applicable.**

- (4) *The combination will result in building envelopes on the combined parcels that will allow for the placement of buildings and structures in a manner consistent with the existing rhythm and pattern of development within 500 feet in all directions in the same zone district.*

**Given the existing conditions and variety of buildings and parcel sizes surrounding the subject properties, the proposed lot combination and building envelope appear to meet this requirement.**

- (5) *Any due or unpaid taxes or special assessments upon the property have been paid in full.*

There are no outstanding taxes due on this property.

**The proposal meets this requirement.**

- (6) *The combination will not adversely affect the interest of the public or the abutting property owners. In making this determination, the City Commission shall consider, but not be limited to the following:*

*a.) The location of proposed buildings or structures, the location and nature of vehicular ingress or egress so that the use or appropriate development of adjacent land or buildings will not be hindered, nor the value thereof impaired.*

On June 8<sup>th</sup>, 2022, the Planning Board recommended approval of the Final Site Plan

and SLUP for Gasow Veterinary Clinic. The applicant has coordinated with the City's Engineering Department and MDOT to create a safer turning radius from southbound Woodward Ave. The applicant is also constructing a large screen wall to separate the vet clinic from neighboring properties in order to minimize its impact.

**The proposed lot combination does not appear to hinder the use, development, or value of adjacent land.**

*b.) The effect of the proposed combination upon any floodplain areas, wetlands and other natural features and the ability of the applicant to develop a buildable site on the resulting parcel without unreasonable disturbances of such natural features.*

**The property is not located in a floodplain or wetlands, nor adjacent to a floodplain or wetlands. Additionally, there are no natural features on the site.**

*c.) The location, size, density and site layout of any proposed structures or buildings as they may impact an adequate supply of light and air to adjacent properties and the capacity of essential public facilities such as police and fire protection, drainage structures, municipal sanitary sewer and water, and refuse disposal.*

**The proposed two-story veterinary clinic and lot combination does not appear to impact the supply of light and air to adjacent properties or the ability of the City to provide essential services.**

**LEGAL REVIEW:**

The City Attorney has reviewed the application and supporting documentation and has no objections as to form or process.

**FISCAL IMPACT:**

There are no fiscal impacts for this agenda item.

**PUBLIC COMMUNICATIONS:**

As required for lot combinations, a legal ad will be placed in a newspaper of local circulation to advertise the nature of the request in advance of the June 5<sup>th</sup>, 2023 public hearing at the City Commission, and notices will be sent out to all property owners and tenants within 300 ft. of the property.

**SUMMARY:**

The Planning Division requests that the City Commission consider setting a public hearing date of June 5<sup>th</sup>, 2023 for the lot combination of 36877 Woodward Ave, Parcel ID #19-25-101-008, 19-25-101-009, 19-25-101-010, and 19-25-101-011.

**ATTACHMENTS:**

- Registered Land Surveys & Parcel Information
- Combination of Platted Lots Application
- Approved Site Plans (July 22nd, 2022)

**SUGGESTED ACTION:**

Make a motion adopting a resolution to set a public hearing date of June 5<sup>th</sup>, 2023 for the proposed lot combination of 36877 Woodward Ave, Parcel ID #19-25-101-008, 19-25-101-009, 19-25-101-010, and 19-25-101-011.

**Existing Parcels (4)**

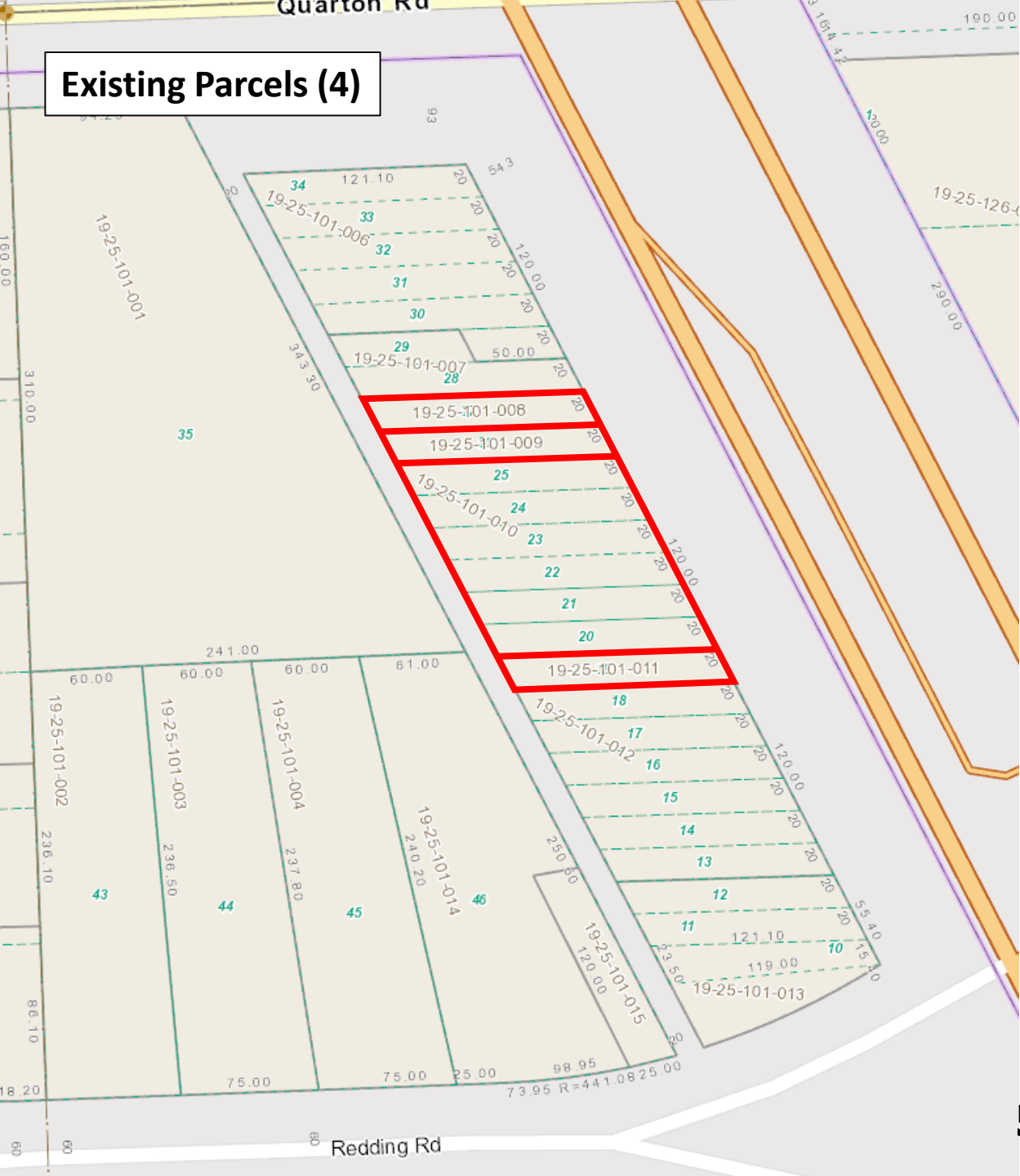

**Proposed Parcel**

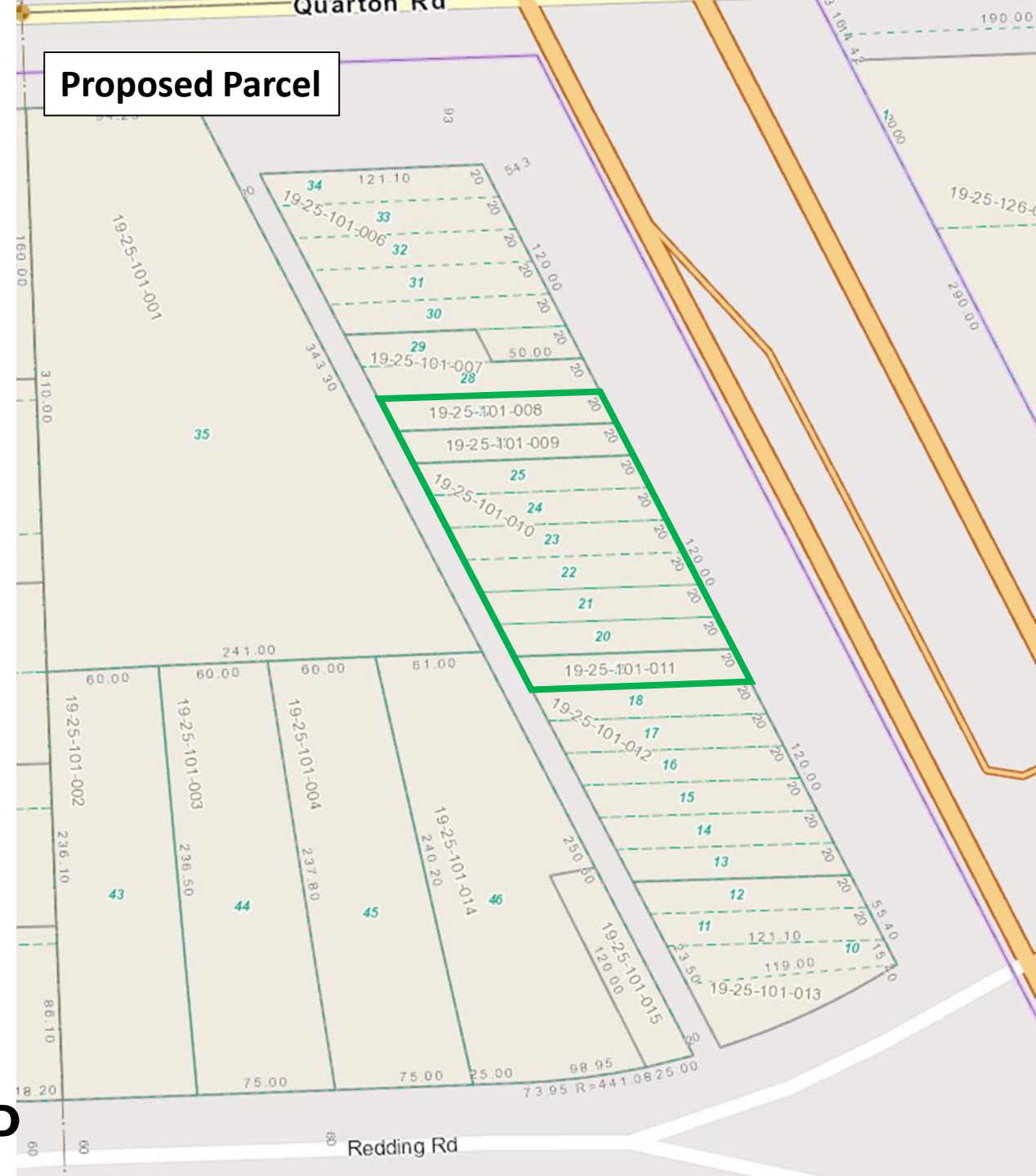



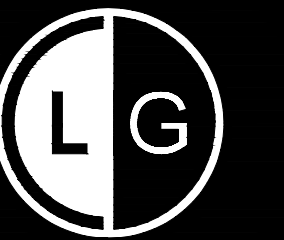

LINDEN GROUP

ARCHITECTURE  
LAND PLANNING  
INTERIOR ARCHITECTURE  
LANDSCAPE ARCHITECTURE  
10100 ORLAND PARKWAY SUITE 110  
ORLAND PARK, ILLINOIS 60467  
(708) 799-4400  
WWW.LINDENGROUPINC.COM



RWE  
DESIGN BUILD  
1303 Ogden Ave.  
Downers Grove, IL 60515  
(630) 734-0883

**GASOW VETERINARY  
HOSPITAL**  
36877 WOODWARD AVENUE  
BIRMINGHAM, MICHIGAN 48009

DATE	DESCRIPTION
02-23-2022	AS SITE PLAN REVIEW
04-12-2022	AS SITE PLAN REVIEW REVISIONS
06-03-2022	AS FINAL SITE PLAN APPROVAL

**2021-0131**  
PROJECT NUMBER

**06-03-2022**  
DATE

**AS** **MM**  
DRAWN BY FINAL REVIEW

COPYRIGHT - LINDEN GROUP INC.  
ALL RIGHTS RESERVED.  
ALL DRAWING SPECIFICATIONS, NOTES, CONDITIONS, AMENDMENTS  
AND REVISIONS REPRESENTED OR REFERRED TO IN THESE DOCUMENTS  
ARE HEREBY ACCEPTED BY THE CLIENT AND CONTRACTOR AND THE CONTRACTOR  
WARRANTS THAT THE WORK OF THE ARCHITECT SHALL BE ACCORDING TO  
ANY PERIODIC FOR ANY PERIODS BEFORE THE CONTRACT SIGNATURE  
AUTHORIZATION OF LINDEN GROUP INC.

SHEET TITLE  
**OFFSITE PARKING  
AND OVERALL PLAN**

SHEET NUMBER  
**SP-2**



**OFFSITE PARKING AND  
OVERALL AREA PLAN**

SCALE: 1" = 20'-0"

P:\2021\2021-0131\Gasow Vet\2021-0131\_Site Plan\2021-0131\_Site Plan.dwg, 6/2/2022 11:04 AM, 4526020201, SP-2

# Overview



	2 Foot Contours		100 yr - FEMA Floodplain
	5 Foot Contours		100 yr (detailed) - FEMA Floodplain
	FEMA Base Flood Elevations		500 yr - FEMA Floodplain
	FEMA Cross Sections		FLOODWAY - FEMA Floodplain

Disclaimer: The information provided herewith has been compiled from recorded deeds, plats, tax maps, surveys and other public records. It is not a legally recorded map or survey and is not intended to be used as one. Users should consult the information sources mentioned above when questions arise. FEMA Floodplain data may not always be present on the map.

**OAKLAND COUNTY MICHIGAN**  
Economic Development & Community Affairs  
**David Coulter**  
Oakland County Executive

Date Created: 7/18/2022  
  
**NORTH**  
1 inch = 200 feet



THIS DRAWING IS PRELIMINARY UNTIL SIGNED AND SEALED BY THE LICENSED PROFESSIONAL NOTED BELOW.  
PROFESSIONAL SEAL

Dr. Al Gonzalez P.E.  
DOTec Engineering  
424 Jefferson Street  
St. Charles, MO 63301  
Ph 636-724-9872  
Fx 636-724-9032  
WWW.DOTECENGINEERING.COM  
ALG@DOTECENGINEERING.COM

THE PROFESSIONAL ENGINEER WAIVES ANY AND ALL RESPONSIBILITY AND LIABILITY FOR PROBLEMS WHICH MAY OCCUR OR FAIL TO FOLLOW THESE PLANS, SPECIFICATIONS AND DESIGN INTENT THEY COPY, OR FOR PROBLEMS WHICH ARE PROBABLY CAUSED BY TO OBTAIN AND/OR FOLLOW THE PROFESSIONAL ENGINEER'S GUIDANCE WITH RESPECT TO ANY ERRORS, OMISSIONS, INCONSISTENCIES, AMBIGUITIES, OR CONFLICTS WHICH ARE ALLEGED TO BELONG TO THE CONTRACTOR IN FULL COMPLIANCE WITH ALL APPLICABLE CODES AND REGULATIONS. PROFESSIONAL ENGINEER TO BE NOTIFIED PRIOR TO CONSTRUCTION IN THE EVENT OF CODE REVISION OR CHANGES.

EXISTING LOTS

#	REVISION DATE	DESCRIPTION

SHEET NAME:  
**EXISTING LOT PLAN**

DATE: 7-18-2022

PROJECT: **GASOW VETERINARY HOSPITAL**  
CLIENT: **36877 WOODWARD AVENUE BIRMINGHAM, MICHIGAN 48009**  
SHEET NUMBER: **C-1**  
PROJECT NUMBER: 2202043  
DRAWN BY: ZSK  
CHECKED BY: ALG  
CONSTRUCTION DOCUMENTS

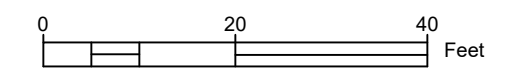

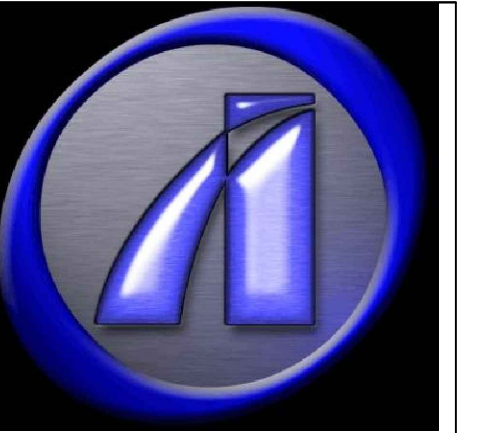

THIS DRAWING IS PRELIMINARY  
UNTIL SIGNED AND SEALED BY  
THE LICENSED PROFESSIONAL  
NOTED BELOW.  
PROFESSIONAL SEAL

Dr. Al Gonzalez P.E.  
DOTec Engineering  
424 Jefferson Street  
St. Charles, MO 63301  
Ph 636-724-9872  
Fx 636-724-9032  
WWW.DOTECENGINEERING.COM  
ALG@DOTECENGINEERING.COM

THE PROFESSIONAL ENGINEER WAIVES ANY AND ALL RESPONSIBILITY  
AND LIABILITY FOR PROBLEMS WHICH ARISE FROM FAILURE TO  
FOLLOW THESE PLANS, SPECIFICATIONS AND DESIGN INTENT THEY  
COPY, OR FOR PROBLEMS WHICH ARISE FROM OTHERS FAILING  
TO OBTAIN AND/OR FOLLOW THE PROFESSIONAL ENGINEER'S  
GUIDANCE WITH RESPECT TO ANY ERRORS, OMISSIONS,  
INCONSISTENCIES, AMBIGUITIES, OR CONFLICTS WHICH ARE  
ALLEGED TO BELONG TO THE CONTRACTOR IN FULL CONFORMANCE  
WITH ALL APPLICABLE CODES AND REGULATIONS. PROFESSIONAL  
ENGINEER TO BE NOTIFIED PRIOR TO CONSTRUCTION IN THE EVENT  
OF CODE REVISION OR CHANGES.

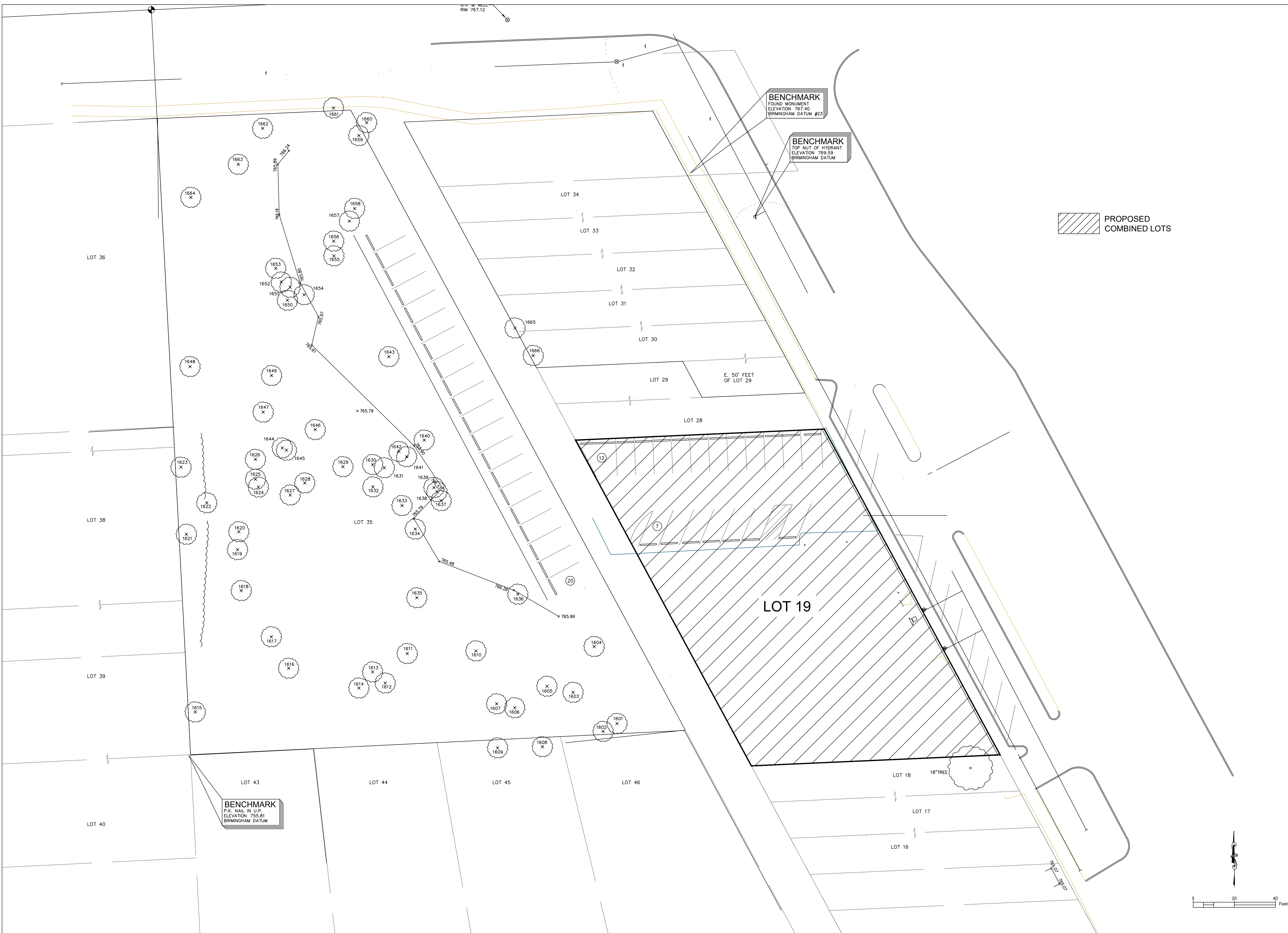

PROPOSED  
COMBINED LOTS

#	REVISION DATE	DESCRIPTION

SHEET NAME:  
PROPOSED LOT PLAN

DATE: 7-18-2022

PROJECT:  
GASOW VETERINARY  
HOSPITAL  
CLIENT:  
36877 WOODWARD  
AVENUE BIRMINGHAM,  
MICHIGAN 48009

SHEET NUMBER:  
C-2

PROJECT NUMBER: 2202043  
DRAWN BY: ZSK  
CHECKED BY: ALG  
CONSTRUCTION DOCUMENTS



- LEGEND**
- ASPH = Asphalt
  - C = Cable Service
  - CATV = Cable Television/Box/Riser
  - CB = Catch Basin
  - CO = Clean Out
  - CONC = Concrete
  - E = Electric Service
  - EM = Electric Meter
  - EC = Electric Conduit/Riser
  - FI = Found Iron
  - FIP = Found Iron Pipe
  - FMON = Found Monument
  - G = Gas Service/Gas Main
  - GL = Ground Light
  - GM = Gas Meter
  - GP = Guard Post
  - GV = Gate Valve
  - HYD = Hydrant
  - LP = Light Pole
  - L/S = Landscape
  - MH = Manhole
  - MON = Monument
  - MW = Monitor Well
  - OH LINES = Overhead Lines
  - P = Phone
  - PH = Physically Hand-drawn
  - PVI = Post Indicator Valve
  - P/L = Property Line
  - PM = Parking Meter
  - ROW = Right of Way
  - SAN = Sanitary Sewer
  - SB = Stop Box (Water)
  - SI = Set Iron
  - SO = Shutoff (Water)
  - SS = Storm Sewer
  - STM = Transformer
  - TRANS = Transformer
  - UG = Underground
  - UP = Utility Pole
  - WM = Water Main
  - (R) = Record Measurement
  - (M) = Surveyed Measurement
  - (C) = Calculated

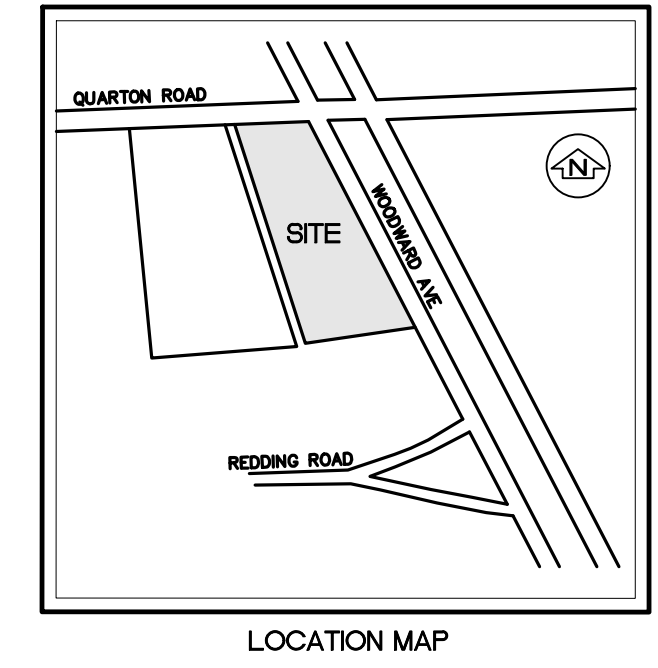
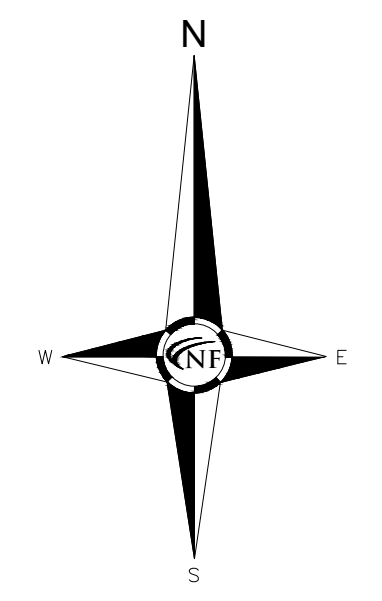

**LEGAL DESCRIPTION- PARENT PARCEL**  
 Land in the City of Birmingham, Oakland County, Michigan, described as follows:  
 Lots 19 through 27, both inclusive, except the Easterly 1 foot as measured at right angles to Woodward Avenue, also Lot 35 of Quarton Lake Estates Replat of East part of Quarton Lake Estates Subdivision according to the plat thereof recorded in Liber 38 of Plats, Pages 24 and 24A of Oakland County Records.

P.L.N.: 19-25-101-010 (Lots 20-25) 36877 Woodward Avenue  
 19-25-101-008 (Lot 26) Woodward Avenue  
 19-25-101-008 (Lot 27) Woodward Avenue  
 19-25-101-001 (Lot 35) Woodward Avenue  
 19-25-101-011 (Lot 19) Woodward Avenue

**PROPOSED LEGAL DESCRIPTION (04-04-2023)**  
 Land in the City of Birmingham, Oakland County, Michigan, described as follows:  
 Lots 19 through 27, except the Easterly 1 foot as measured at right angles to Woodward Avenue, Quarton Lake Estates Replat of East part of Quarton Lake Estates Subdivision according to the plat thereof recorded in Liber 38 of Plats, Pages 24 and 24A of Oakland County Records; All being more particularly described as: Beginning at the Southwest corner of said Lot 19; thence North 24 degrees 12 minutes 50 seconds West, 180.00 feet along the Westerly line of said Lots 19 through 27 (said line also being the Easterly line of a 20 foot Public Alley) to a point on the Northwest corner of said Lot 27; thence North 88 degrees 23 minutes 35 seconds West, 119.99 feet to a point on the Westerly line of Woodward Avenue (201 feet wide); thence South 24 degrees 12 minutes 50 seconds East, 180.00 feet along said line of Woodward Avenue to a point on the South line of said Lot 19; thence North 88 degrees 23 minutes 35 seconds West, 119.99 feet along the South line of said Lot 19 to the point of beginning.

Gross Land Area: 19,442 square feet or 0.446 acres.

**BASIS OF BEARING NOTE**  
 The basis of bearing for this survey was established by Woodward Avenue as shown on the recorded Plat of QUARTON LAKE ESTATES REPLAT OF EAST PART OF QUARTON LAKE ESTATES SUBDIVISION

**UTILITY NOTE**  
 All utilities are underground unless otherwise noted.  
 The utilities shown on this survey were determined by field observation. All locations are approximate. The location of any other underground services which may exist can only be depicted if a Utility Plan is furnished to the surveyor.

**NOTE:** DTE has new regulations that may impact development outside their easement or the public right of way. Client shall contact DTE to determine the "New Structures and Power Line" requirements as they may apply to any future building or renovation of a structure. DTE Energy can be contacted at 800-477-4747.

**FLOOD HAZARD NOTE**  
 The Property described on this survey does not lie within a Special Flood Hazard Area as defined by the Federal Emergency Management Agency, the property lies within Zone X of the Flood Insurance Rate Map identified as Map No. 261250556F bearing an effective date of 09-29-2006.

**EASEMENT NOTES**  
 Easements shown or noted on this survey were obtained from Title Commitment No. 85215, with a commitment date of November 12, 2018, issued by Absolute Title Inc, AND Title Commitment No. NCS-938243-MICH, with a commitment date of November 16, 2018, issued by First American Title Insurance Company.

This survey may not show all easements of record unless an updated Title Search, Commitment or Policy is furnished to the surveyor.



**NOWAK & FRAUS ENGINEERS**  
 46777 WOODWARD AVENUE  
 PONTIAC, MI 48342  
 TEL. (248) 332-7931  
 FAX. (248) 332-8257  
 EMAIL: www.nowakfraus.com

**PROJECT**  
 GASOW VETERINARY HOSPITAL

**PROJECT LOCATION**  
 No. 36877  
 Woodward Avenue  
 Part of the NW. 1/4 of  
 Section 25, T.2N., R.10E.,  
 City of Birmingham,  
 Oakland County, MI

**SHEET**  
 PROPOSED  
 LOT COMBINATION

**REVISIONS**  
 11-01-2018 Original Survey  
 06-23-2019 Field Survey Updated

**DRAWN BY:**  
 K.N.  
**APPROVED BY:**  
 K.N./R.FRAUS  
**EMAIL:**  
 rfraus@nfe-engr.com

**DATE ISSUED:**  
 April 10, 2023  
**SCALE:**  
 1"=20'  
**NFE JOB NO.** K700 **SHEET NO.** 1 of 1





## Combination of Platted Lots Application Planning Division

*Form will not be processed until it is completely filled out.*

### 1. Applicant

Name: 36877 WOODWARD AVENUE LLC/ROMEO PLANK PROPERTIES  
Address: 36877 WOODWARD AVENUE  
BIRMINGHAM, MICHIGAN 48009  
Phone Number: (248) 644-7171  
Fax Number: \_\_\_\_\_  
Email address: mbailey@mtbpartnersllc.com

### 2. Property Owner

Name: 36877 WOODWARD AVENUE LLC/ROMEO PLANK PROPERTIES  
Address: 36877 WOODWARD AVENUE  
BIRMINGHAM, MICHIGAN 48009  
Phone Number: (248) 644-7171  
Fax Number: \_\_\_\_\_  
Email address: mbailey@mtbpartnersllc.com

### 3. Applicant's Attorney/Contact Person

Name: Michael Matthys, Linden Group Architects  
Address: 10100 Orland Parkway, Orland Park IL 60467  
Phone Number: 7087994400  
Fax Number: \_\_\_\_\_  
Email address: mmatthys@lindengroupinc.com

### 4. Project Designer/Developer

Name: RWE DESIGN-BUILD  
Address: 1303 OGDEN AVENUE  
DOWNERS GROVE, ILLINOIS 60515  
Phone Number: (630) 734-0883  
Fax Number: \_\_\_\_\_  
Email address: ken@rwedesignbuild.com

### 5. Project Information

Address/Location of Property: 36877 WOODWARD AVENUE  
BIRMINGHAM, MICHIGAN 48009  
Sidwell #: 19-25-101-010 (lots 20-25); 009 (lot 26); 008 (lot 27); 011 (lot 19)  
Parcel #: 19-27  
Current Zoning: TZ-3

Legal Description: Lots 19-27, both inclusive, except Easterly 1 foot as measured at right angles to Woodward Avenue.

### 6. Required Attachments

- I. Two (2) copies of a *registered* land survey showing:
  - i. All existing and proposed platted lot lines;
  - ii. Legal descriptions of proposed lots;
  - iii. Locations of existing/surrounding structures for at least 500 ft. in all directions;
  - iv. Footprints of proposed development including proposed building envelope with front, side and rear setbacks clearly marked;

- II. One (1) digital copy of plans;
- III. Proof of ownership;
- IV. Written statement of reasons for request;
- V. A letter of authority or power of attorney in the event the application is made by a person other than the property owner;
- VI. Sketches of proposed development (*optional*);
- VII. Other data having a direct bearing on the request.
- VIII. Any other data requested by the Planning Board, Planning Department, or other City Departments.

### 7. Details of the Proposed Development (attach separate sheet if necessary)

DEMOLITION OF EXISTING ONE-STORY STRUCTURE AND CONSTRUCTION OF NEW 12,000 SQUARE FOOT PARTIAL TWO-STORY STRUCTURE  
EXISTING PARKING LOTS AND SIDEWALKS TO BE REPAIRED AND REPLACED AS REQUIRED, AND WORK PURSUANT TO NEW CONSTRUCTION SCOPE. NEW BUILDING USE WILL  
REMAIN AS GASOW VETERINARY HOSPITAL. EXTERIOR MATERIALS WILL INCLUDE BRICK, STONE, GLASS, AND METAL PANEL.

(I), (We), the undersigned, do hereby request to combine lots of record in the City of Birmingham, Oakland County, Michigan.  
(I), (We), do hereby swear that all of the statements, signatures, and descriptions appearing on and with this request are in all respects true and accurate to the best of (my), (our), knowledge.

*By providing your e-mail to the City, you agree to receive news notifications from the City. If you do not wish to receive these messages, you may unsubscribe at any time.*

Signature of Property Owner:  Date: 7/18/2022

Print Name: Michael T. Bailey

Signature of Applicant:  Date: 7/18/2022

Print Name: Michael T Bailey

*Office Use Only*

Application#: \_\_\_\_\_ Date Received: \_\_\_\_\_ Fee: \_\_\_\_\_

Date of Approval: \_\_\_\_\_ Date of Denial: \_\_\_\_\_ Reviewed By: \_\_\_\_\_

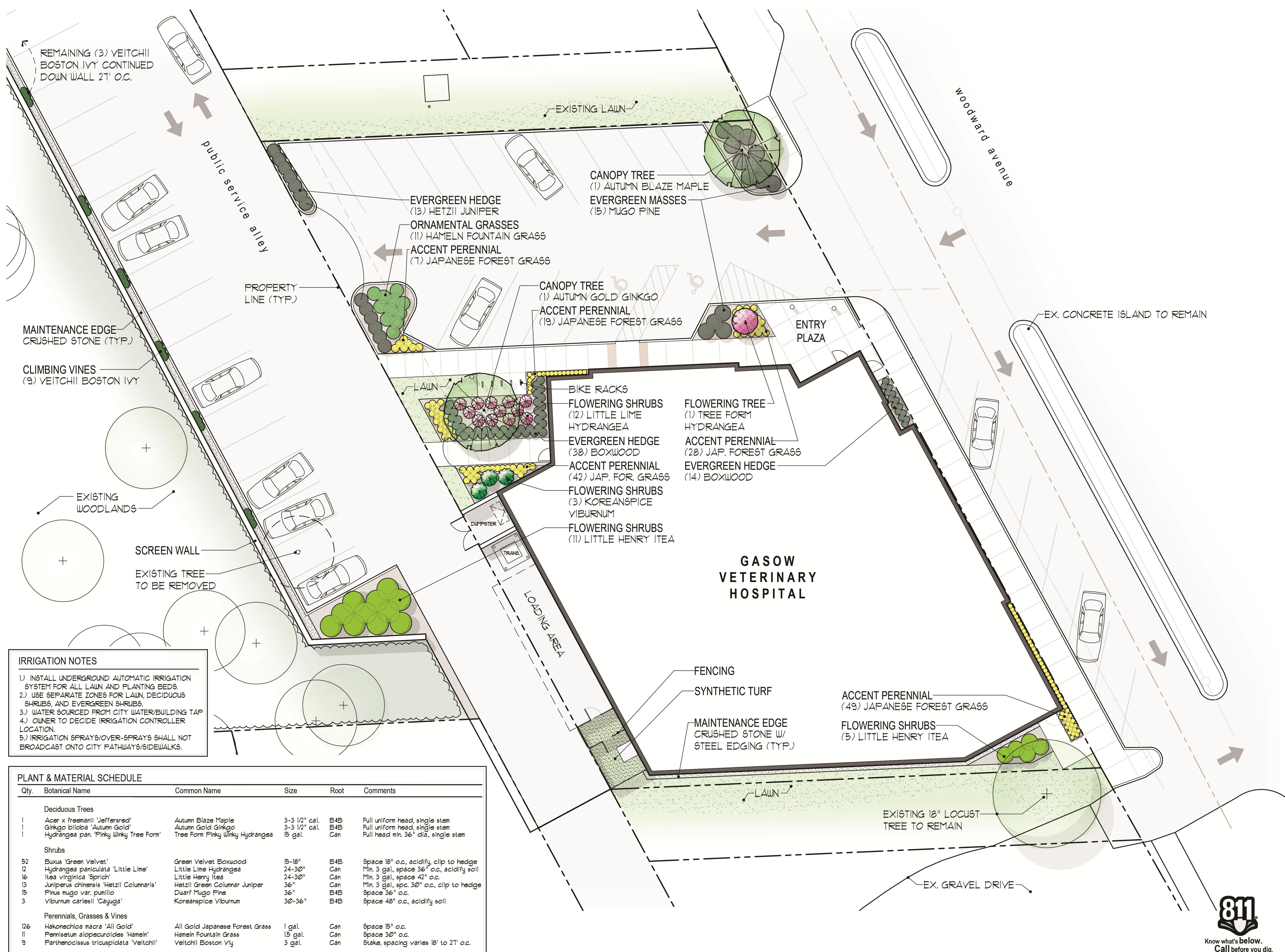

**IRRIGATION NOTES**

- 1) INSTALL UNDERGROUND AUTOMATIC IRRIGATION SYSTEM FOR ALL LAWN AND PLANTING BEDS.
- 2) USE SEPARATE ZONES FOR LAWN, DECIDUOUS SHRUBS, AND EVERGREEN SHRUBS.
- 3) WATER SOURCED FROM CITY WATER/BUILDING TAP
- 4) OWNER TO DECIDE IRRIGATION CONTROLLER LOCATION.
- 5) IRRIGATION SPRAYS/OVER-SPRAYS SHALL NOT BROADCAST ONTO CITY PATHWAYS/SIDEWALKS.

Qty.	Botanical Name	Common Name	Size	Root	Comments
<b>Deciduous Trees</b>					
1	Acer x freemanii 'Jeffersred'	Autumn Blaze Maple	3-3 1/2" cal.	B4B	Full uniform head, single stem
1	Ginkgo biloba 'Autumn Gold'	Autumn Gold Ginkgo	3-3 1/2" cal.	B4B	Full uniform head, single stem
1	Hydrangea pan. 'Pinky Winky Tree Form'	Tree Form Pinky Winky Hydrangea	15 gal.	Can	Full head min. 36" dia., single stem
<b>Shrubs</b>					
52	Buxus 'Green Velvet'	Green Velvet Boxwood	15-18"	B4B	Space 18" o.c., acidify, clip to hedge
12	Hydrangea paniculata 'Little Lime'	Little Lime Hydrangea	24-30"	Can	Min. 3 gal., space 36" o.c., acidify soil
16	Itea virginica 'Sprich'	Little Henry Itea	24-30"	Can	Min. 3 gal., space 42" o.c.
13	Juniperus chinensis 'Hetzlil Columnaris'	Hetzlil Green Columnar Juniper	36"	Can	Min. 3 gal., spc. 30" o.c., clip to hedge
15	Pinus mugo var. pumilio	Dwarf Mugo Pine	36"	B4B	Space 36" o.c.
3	Viburnum carlesii 'Cayuga'	Korean Spice Viburnum	30-36"	B4B	Space 48" o.c., acidify soil
<b>Perennials, Grasses &amp; Vines</b>					
126	Hakonechloa macra 'All Gold'	All Gold Japanese Forest Grass	1 gal.	Can	Space 15" o.c.
11	Fernisetum alopecuroides 'Hameln'	Hameln Fountain Grass	15 gal.	Can	Space 30" o.c.
9	Parthenocissus tricuspidata 'Veitchii'	Veitchii Boston Ivy	3 gal.	Can	Stake, spacing varies 18' to 27' o.c.



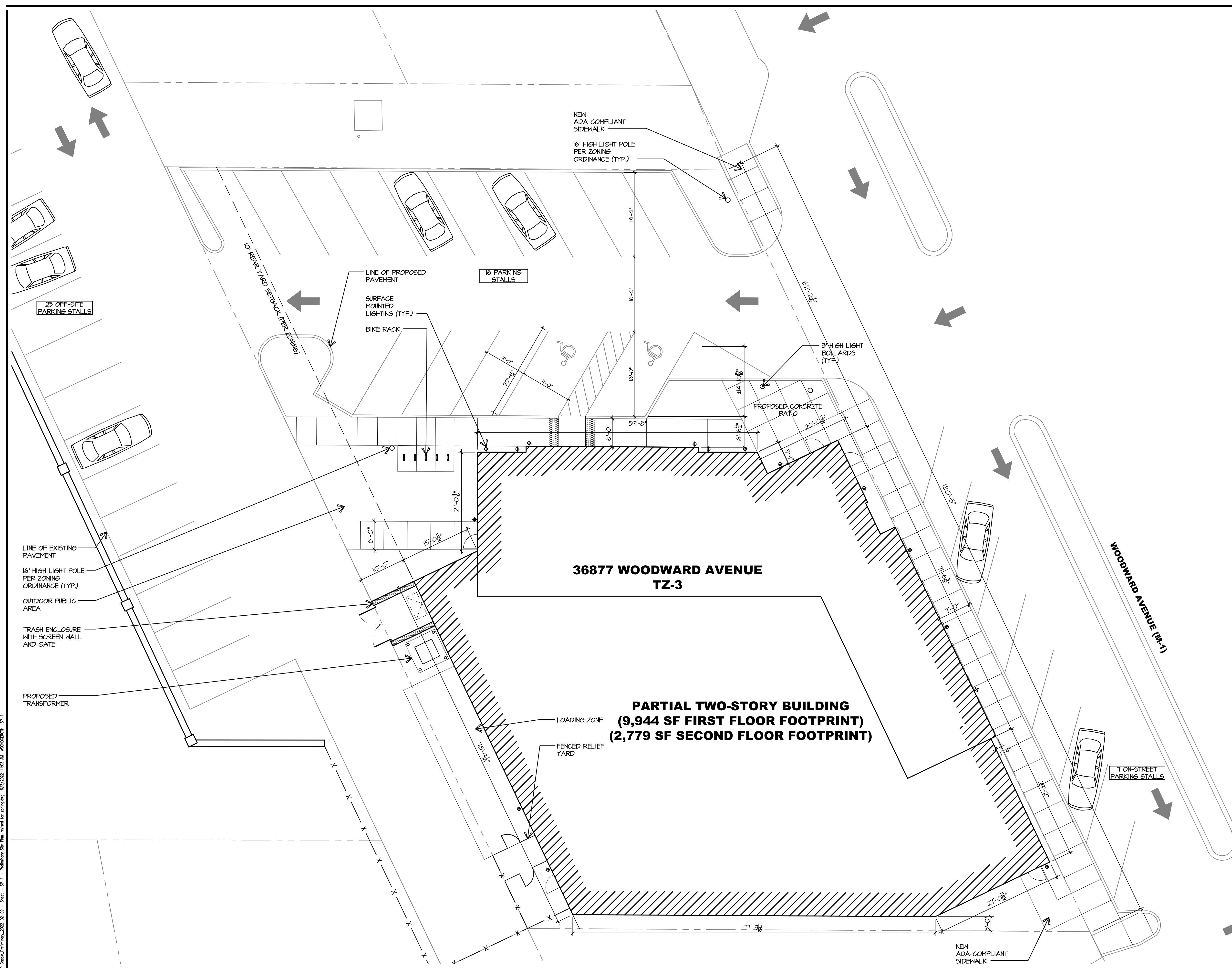

Gasow Veterinary Hospital - Variance Chart

Requested Variances	Required	Existing	Proposed	Variance Amount
Variance A	75% of Frontage; With in 0-5 feet (135' required)	180' (Total Stree Frontage)	100'-0" (55%)	35'-0"
Variance B	Max 25% of Frontage parking lot (max 45')	180' (Total Stree Frontage)	57'-0" (32%)	12'-0"
Variance C	1 usable entrance for every 50' of frontage (2 required)	100'-8" wide building	1 entrance	1 entrance

**ZONING DATA - 36877 WOODWARD AVENUE**

36877 WOODWARD AVENUE, BIRMINGHAM, MICHIGAN  
 PER BIRMINGHAM ZONING ORDINANCE (AMENDED DECEMBER 19, 2021) AND ZONING MAP (AMENDED AUGUST 2022)

**TZ-3** TRANSITION ZONE DISTRICT (TZ3) - PROVIDES FOR A REASONABLE AND ORDERLY TRANSITION FROM, AND BUFFER BETWEEN, COMMERCIAL USES AND PREDOMINANTLY SINGLE-FAMILY RESIDENTIAL AREAS OR FOR PROPERTY WHICH EITHER HAS DIRECT ACCESS TO A MAJOR TRAFFIC ROAD OR IS LOCATED BETWEEN MAJOR TRAFFIC ROADS AND PREDOMINANTLY SINGLE-FAMILY RESIDENTIAL AREAS.

**USES PERMITTED PER TABLE 5.1**

VETERINARY CLINIC	EXISTING ANIMAL HOSPITAL USE, 11,450 SF.	EXISTING SPECIAL LAND USE, 1,171 SF.
PROPOSED ANIMAL HOSPITAL USE:		

**SETBACKS (PER 2-46.173 DISTRICT STANDARDS)**

FRONT YARD	ALLOWED 0'-0" - 5'-0"	ACTUAL/PROPOSED PER PLAN
SIDE YARD	0'-0"	PER PLAN
REAR YARD	10'-0"	PER PLAN
MAX. FLOOR AREA	N/A	12,723 SF
MAX. BUILDING HEIGHT (STORIES)	4 STORIES	2 STORIES
MAX. BUILDING HEIGHT (FEET)	42 FEET	TBD
MIN LOT AREA =	N/A	71,911 SF (PER ALTA)

**OFF-STREET PARKING REQUIREMENTS (PER TABLE 5.A.2 AND CHAPTER III)**

COMMERCIAL/PROFESSIONAL USE = 1/300 SF OF GROSS AREA (PER 4.52 OF ZONING ORDINANCE)

PARKING LOT SETBACKS = PERMITTED IN SIDE AND REAR YARDS PERMITTED ON ALL STREET FRONTAGES

SIZE = 9 FT WIDE X 18 FT LENGTH, 24 FT AISLES (FOR 90 DEGREE PARKING) 18 FT AISLES FOR ONE-WAY

FIRE LANE = 20 FEET WIDTH

SCREENING = REQUIRED WHERE VISIBLE FROM STREET 3 FEET MIN FENCE, HEDGE OR HALL

INTERIOR LANDSCAPING = NO LESS THAN 5% OF TOTAL PARKING LOT INTERIOR AREA INTERIOR PLANTING AREA TO BE NO LESS THAN 150 SF IN SIZE AT LEAST ONE CANOPY TREE FOR EACH 150 SF IN EACH INTERIOR PLANTING AREA INTERIOR PLANTING AREAS SHALL BE LOCATED IN A MANNER THAT BREAKS UP EXPANSE OF PAVEMENT

**OFF-STREET PARKING CALCULATION**

MEDICAL USE = 3500 SF / 150 X 1 =	36 PARKING SPACES
HOSPITAL USE = 1 SPACE / 4 BEDS X 13 BEDS =	3 PARKING SPACES
OFFICE USE = 1653 SF / 300 X 1 =	6 PARKING SPACES
TOTAL REQUIRED:	45 PARKING SPACES

A. OFF STREET PARKING ON SITE = 16 PARKING SPACES  
 B. OFF STREET PARKING OFF SITE = 25 PARKING SPACES  
 C. STREET PARKING = 7 PARKING SPACES  
 ACTUAL PARKING PROVIDED = 48 PARKING SPACES

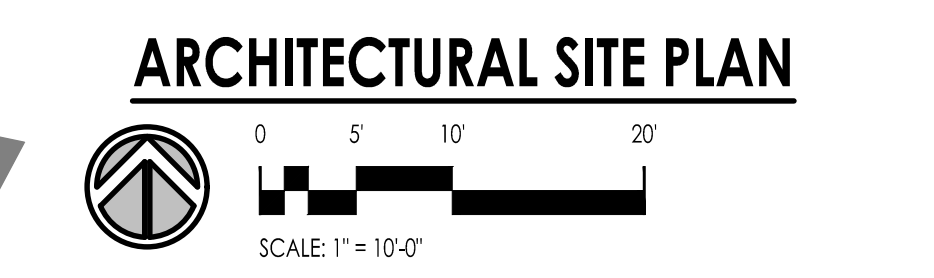
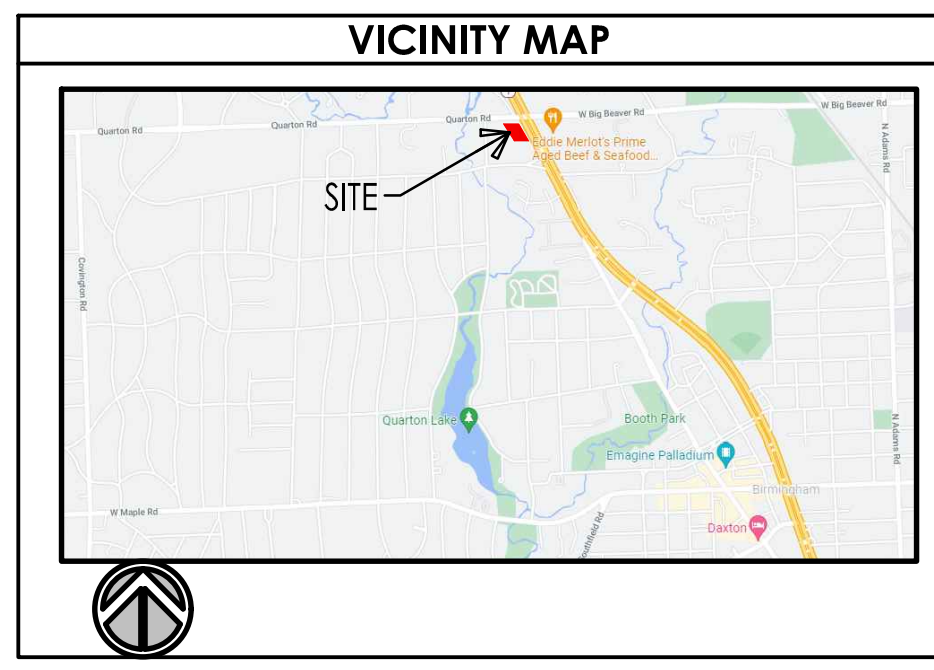

ARCHITECTURE  
 LAND PLANNING  
 INTERIOR ARCHITECTURE  
 LANDSCAPE ARCHITECTURE

10100 ORLAND PARKWAY SUITE 110  
 ORLAND PARK, ILLINOIS 60467  
 (708) 799-4400  
 WWW.LINDENGROUPINC.COM



1303 Ogden Ave.  
 Downers Grove, IL 60515  
 (630) 734-0883

**GASOW VETERINARY HOSPITAL**

36877 WOODWARD AVENUE  
 BIRMINGHAM, MICHIGAN 48009

DATE: 02-23-2022 AS  
 04-12-2022 AS  
 06-03-2022 AS

DESCRIPTION:  
 SITE PLAN REVIEW REVISIONS  
 SITE PLAN REVIEW REVISIONS  
 FINAL SITE PLAN APPROVAL

**2021-0131**  
 PROJECT NUMBER

**06-03-2022**  
 DATE

**AS** **MM**  
 DRAWN BY FINAL REVIEW

COPYRIGHT - LINDEN GROUP INC. ALL RIGHTS RESERVED. ALL DRAWING SPECIFICATIONS, NOTES, CONDITIONS, AMENDMENTS AND REVISIONS REPRESENTED OR REFERRED TO IN THESE DOCUMENTS ARE HEREBY ACCEPTED BY THE CLIENT AND THE PROJECTOR OF ANY WORK DONE BY THE CLIENT OF THE WORK SHALL BE ACCORDING TO ANY PROVISIONS IN ANY PERMITS, ORDINANCES, AND THE GENERAL PRACTICES AND STANDARDS OF LINDEN GROUP INC.

SHEET TITLE  
**ARCHITECTURAL SITE PLAN**

SHEET NUMBER  
**SP-1**



LINDEN GROUP

ARCHITECTURE  
LAND PLANNING  
INTERIOR ARCHITECTURE  
LANDSCAPE ARCHITECTURE  
10100 ORLAND PARKWAY SUITE 110  
ORLAND PARK, ILLINOIS 60467  
(708) 799-4400  
WWW.LINDENGROUPINC.COM



RWE  
DESIGN BUILD  
1303 Ogden Ave.  
Downers Grove, IL 60515  
(630) 734-0883

**GASOW VETERINARY  
HOSPITAL**  
36877 WOODWARD AVENUE  
BIRMINGHAM, MICHIGAN 48009

DATE	DESCRIPTION
02-23-2022	AS SITE PLAN REVIEW
04-12-2022	AS SITE PLAN REVIEW REVISIONS
06-03-2022	AS FINAL SITE PLAN APPROVAL

**2021-0131**  
PROJECT NUMBER

**06-03-2022**  
DATE

**AS** **MM**  
DRAWN BY FINAL REVIEW

COPYRIGHT - LINDEN GROUP INC.  
ALL RIGHTS RESERVED.  
ALL DRAWING SPECIFICATIONS, NOTES, CONDITIONS, AMENDMENTS  
AND REVISIONS REPRESENTED OR REFERRED TO IN THESE DOCUMENTS  
ARE HEREBY INCORPORATED BY REFERENCE AND THE DRAWING IS TO BE  
UNDERSTOOD AS SUCH. NO PART OF THIS DRAWING IS TO BE REPRODUCED  
OR TRANSMITTED IN ANY FORM OR BY ANY MEANS, ELECTRONIC OR  
MECHANICAL, INCLUDING PHOTOCOPYING, RECORDING, OR BY ANY  
INFORMATION STORAGE AND RETRIEVAL SYSTEM, WITHOUT THE EXPRESS  
AUTHORIZATION OF LINDEN GROUP INC.

SHEET TITLE  
**OFFSITE PARKING  
AND OVERALL PLAN**

SHEET NUMBER  
**SP-2**



**OFFSITE PARKING AND  
OVERALL AREA PLAN**

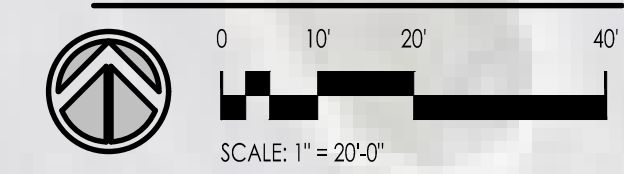

P:\2021\2021-0131\Gasow Vet\2021-0131\_Site Plan\_Preliminary.dwg, 6/2/2022 11:04 AM, 6526022021, SP-2



LINDENGROUP

ARCHITECTURE  
LAND PLANNING  
INTERIOR ARCHITECTURE  
LANDSCAPE ARCHITECTURE  
10100 ORLAND PARKWAY SUITE 110  
ORLAND PARK, ILLINOIS 60467  
(708) 799-4400  
WWW.LINDENGROUPINC.COM



1303 Ogden Ave.  
Downers Grove, IL 60515  
(630) 734-0883

**GASOW VETERINARY  
HOSPITAL**  
36877 WOODWARD AVENUE  
BIRMINGHAM, MICHIGAN 48009

DATE DESCRIPTION  
02-23-2022 AS SITE PLAN REVIEW REVISIONS  
04-12-2022 AS SITE PLAN REVIEW REVISIONS  
06-03-2022 AS FINAL SITE PLAN APPROVAL

**2021-0131**

PROJECT NUMBER

**06-03-2022**

DATE

**AS MM**

DRAWN BY FINAL REVIEW

COPYRIGHT - LINDEN GROUP INC.  
ALL RIGHTS RESERVED.  
ALL DRAWING SPECIFICATIONS, NOTES, CONDITIONS, AMENDMENTS  
AND REVISIONS REPRESENTED OR REFERRED TO IN THESE DOCUMENTS  
ARE HEREBY INCORPORATED BY REFERENCE AND THE PROJECT OR  
OWNER SHALL BE RESPONSIBLE FOR THE ACCURACY AND COMPLETION OF  
ALL INFORMATION FOR ANY PURPOSES WITHOUT THE EXPRESS WRITTEN  
AUTHORIZATION OF LINDEN GROUP INC.

SHEET TITLE  
**FIRST  
FLOOR PLAN**

SHEET NUMBER

**PD1-1**



**PRELIMINARY FIRST FLOOR PLAN**



PD1-1 (2021-0131) Gasow Veterinary Hospital (Preliminary) 2021-0131 - PD1-1 - PRELIMINARY FLOOR PLAN.dwg 6/2/2022 11:00 AM A020220201 PD1-1  
OWNER: MM GROUP INC.

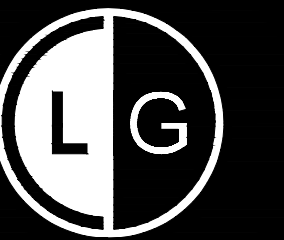

LINDEN GROUP

ARCHITECTURE  
LAND PLANNING  
INTERIOR ARCHITECTURE  
LANDSCAPE ARCHITECTURE  
10100 ORLAND PARKWAY SUITE 110  
ORLAND PARK, ILLINOIS 60467  
(708) 799-4400  
WWW.LINDENGROUPINC.COM



1303 Ogden Ave.  
Downers Grove, IL 60515  
(630) 734-0883

**GASOW VETERINARY  
HOSPITAL**  
36877 WOODWARD AVENUE  
BIRMINGHAM, MICHIGAN 48009

DATE DESCRIPTION  
02-23-2022 AS SITE PLAN REVIEW REVISIONS  
04-12-2022 AS SITE PLAN REVIEW APPROVAL  
06-03-2022 AS FINAL SITE PLAN APPROVAL

**2021-0131**  
PROJECT NUMBER

**06-03-2022**  
DATE

**AS** **MM**  
DRAWN BY FINAL REVIEW

COPYRIGHT - LINDEN GROUP INC.  
ALL RIGHTS RESERVED.  
ALL DRAWING SPECIFICATIONS, NOTES, CONDITIONS, AMENDMENTS  
AND RECORDS REPRESENTED OR REFERRED TO IN THESE DOCUMENTS  
ARE HEREBY ACCEPTED AS PART OF THE CONTRACT AND THE PROJECTOR  
OR ARCHITECT SHALL BE RESPONSIBLE FOR ANY AND ALL RECORDS  
AND RECORDS FOR ANY PROJECTS UNDER THE CONTRACT SPECIFIC  
AUTHORIZATION OF LINDEN GROUP INC.

SHEET TITLE  
**SECOND FLOOR  
PLAN**

SHEET NUMBER  
**PD1-2**

**AIR HANDLING UNIT SCHEDULE**

TAG	MANUFACTURER	MODEL	TONS	SEER /EER	FAN DATA				CEILING DATA				HTG. DATA		ELECTRICAL DATA				MIN O/A [°F]	GAS CONN. SIZE	DRAIN CONN. SIZE	UNIT WT. [LB.]	REMARKS
					CFM	ESP	RPM	HP	TOT. MBH	SENS MBH	EAT [dB]	EAT [WB]	MBH IN	MBH OUT	MCA	MOC P	VOLT	PH					
RT-1	AAON	RN01680EB093C4	3.5	12.2			1760	5										200	3			3514	
RT-2	AAON	RN01380EA092F2	1.4	12			1760	5										200	3			1936	
RT-3	AAON	RN00280EA092K2	1.2	11.4			1760	2										200	3			1223	

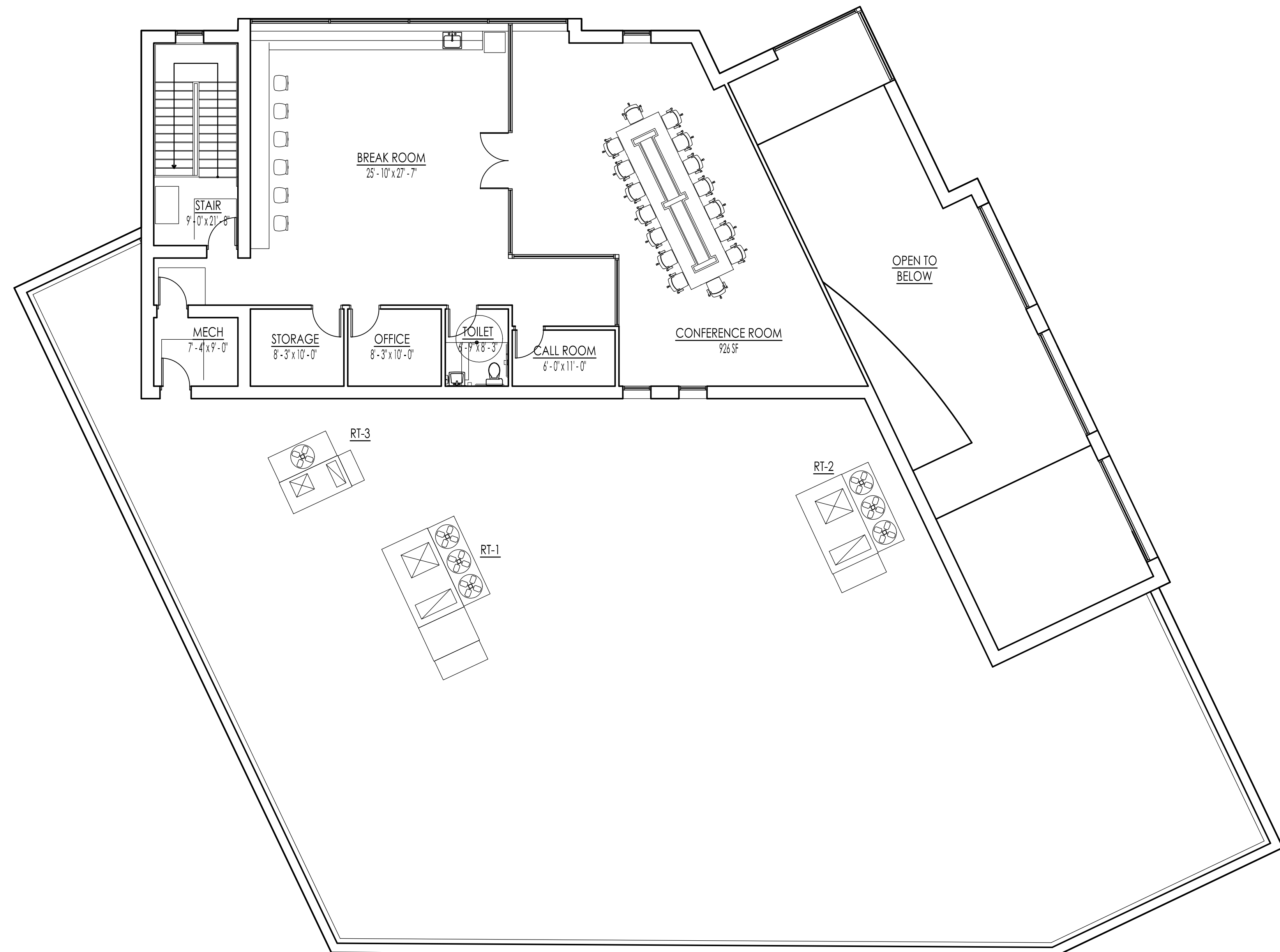

**PRELIMINARY SECOND FLOOR PLAN**

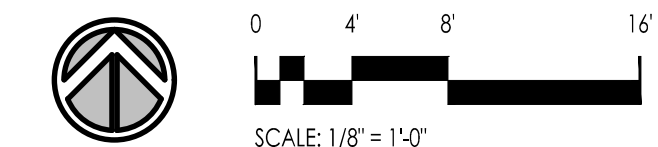

P:\2021\2021-0131\Gasow\_Vet\_Hospital\2021-0131\_MLP\_Gasow\_Preliminary\_2022-02-29 - Sheet - PD-1-1 - PRELIMINARY FLOOR PLAN.dwg 6/27/2022 11:00 AM A509020201 PD1-2

**ARCHITECTURAL SIGN AREA**  
 SIGNAGE LIMITED TO 33% OF OVERALL WALL FRONTAGE OR CANOPY LENGTH  
 WALL SIGNAGE - WOODWARD AVENUE SIDE  
 100'-2" LENGTH x 15" = 150.25 SF MAXIMUM  
 CANOPY SIGNAGE  
 28'-6" / 3 = 9.5 SF MAXIMUM  
 OVERALL AREA OF SIGNAGE: 1.08 SF  
  
**ARCHITECTURAL FLOOR PLAN SYMBOLS**  
 NOTE: SEE MECH, PLUMB, AND ELECTRICAL DRAWINGS FOR ADDITIONAL INFORMATION  
 3 FLOOR PLAN KEYNOTE

- ELEVATION NOTES LEGEND**
- 1 CUT STONE ACCENT
  - 2 STEEL CANOPY
  - 3 SIGNAGE
  - 4 COMPOSITE ALUMINUM
  - 5 ALUMINUM STOREFRONT GLAZING
  - 6 STONE CORNICE
  - 7 METAL COPING
  - 8 METAL MECHANICAL SCREEN WALL
  - 9 EXTERIOR ARCHITECTURAL WALL SCIENCE
  - 10 CUT STONE BASE
  - 11 BRICK 1
  - 12 BRICK 2
  - 13 CUT STONE BASE



**2 NORTH BUILDING ELEVATION**  
 3/16" = 1'-0"  
 SCALE: 3/16" = 1'-0"  



**1 EAST BUILDING ELEVATION**  
 3/16" = 1'-0"  
 SCALE: 3/16" = 1'-0"  

**GLAZING AREAS - 1'-0" TO 8'-0" A.F.F.**

	WALL	TOTAL AREA OF WALL (S.F.)	TOTAL AREA OF STOREFRONT (S.F.)	PERCENTAGE OF WALL AS STOREFRONT	PERCENTAGE OF WALL AS GLAZING PER ZONING ORDINANCE
NORTH		534.2914	196.5	36.77%	30%
EAST		704.6664	504	71.52%	70%

PD1-3 (2021-0131) Drawing Title (Preliminary) 2021-0131 - 0131 - Preliminary Elevation - 06/03/2022 1:00 PM - 6/3/2022 1:00 PM - 6/3/2022 1:00 PM - 6/3/2022 1:00 PM

ARCHITECTURAL FLOOR PLAN SYMBOLS	
NOTE: SEE MECA, PLUMB, AND ELECTRICAL DRAWINGS FOR ADDITIONAL INFORMATION	
3	FLOOR PLAN KEYNOTE

ELEVATION NOTES LEGEND	
1	CUT STONE ACCENT
2	STEEL CANOPY
3	SIGNAGE
4	COMPOSITE ALUMINUM
5	ALUMINUM STOREFRONT GLAZING
6	STONE CORNICE
7	METAL COPING
8	METAL MECHANICAL SCREEN WALL
9	EXTERIOR ARCHITECTURAL WALL SCIENCE
10	CUT STONE BASE
11	BRICK 1
12	BRICK 2
13	CUT STONE BASE



**LINDEN GROUP**

ARCHITECTURE  
LAND PLANNING  
INTERIOR ARCHITECTURE  
LANDSCAPE ARCHITECTURE

10100 ORLAND PARKWAY SUITE 110  
ORLAND PARK, ILLINOIS 60467  
(708) 799-4400  
WWW.LINDENGROUPINC.COM

**RWE**  
DESIGN BUILD

1303 Ogden Ave.  
Downers Grove, IL 60515  
(630) 734-0883



**2 WEST BUILDING ELEVATION**  
3/16" = 1'-0"

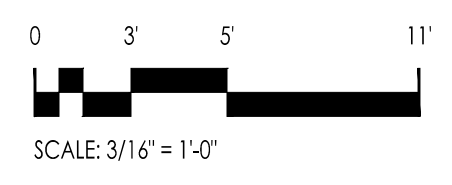

**1 SOUTH BUILDING ELEVATION**  
3/16" = 1'-0"

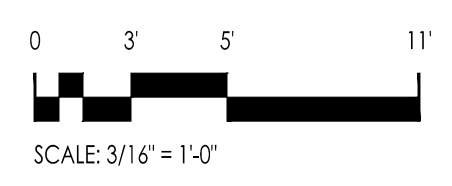

**GASOW VETERINARY HOSPITAL**  
36877 WOODWARD AVENUE  
BIRMINGHAM, MICHIGAN 48009

DATE	DESCRIPTION
02-23-2022	AS SITE PLAN REVIEW
04-12-2022	AS SITE PLAN REVIEW REVISIONS
06-03-2022	AS FINAL SITE PLAN APPROVAL

**2021-0131**  
PROJECT NUMBER

**06-03-2022**  
DATE

**AS** **MM**  
DRAWN BY FINAL REVIEW

COPYRIGHT - LINDEN GROUP INC. ALL RIGHTS RESERVED. ALL DRAWING SPECIFICATIONS, NOTES, CONCEPTS, INFORMATION AND DECISIONS REPRESENTED OR REFERRED TO IN THESE DOCUMENTS ARE THE PROPERTY OF LINDEN GROUP INC. AND SHALL BE THE PROPERTY OF LINDEN GROUP INC. NO PART OF THIS DOCUMENT IS TO BE REPRODUCED OR TRANSMITTED IN ANY FORM OR BY ANY MEANS, WITHOUT THE EXPRESS WRITTEN PERMISSION OF LINDEN GROUP INC.

SHEET TITLE  
**PRELIMINARY S-W ELEVATIONS**

SHEET NUMBER  
**PD1-4**

PD1-4 (2021-0131) Drawing Title (Preliminary) 2021-0131 - 0131 - PD1-4 - Preliminary Elevations - 2-Jan-21 6/9/2022 10:57 AM ASD/MS/001/PD1-4  
 06/03/2022 10:57 AM ASD/MS/001/PD1-4

# Gasow Veterinary Hospital

Woodward Avenue—Birmingham



EXISTING WOODWARD  
AVENUE VIEW



PROPOSED WOODWARD  
AVENUE VIEW



## **MEMORANDUM**

Department of Public Services

**DATE:** May 8, 2023

**TO:** Thomas M. Markus, City Manager

**APPROVED:** Scott Zielinski, DPS Director

**FROM:** Carrie Laird, Parks and Recreation Manager

**SUBJECT:** Birmingham Little League Agreement

---

### INTRODUCTION

Birmingham Little League (BLL) would like to enter into an agreement with the City. This agreement would allow for the BLL to procure, install, and maintain shade coverings over players benches, a total of four (4) for the two (2) improved fields at Kenning Park.

### BACKGROUND:

Birmingham Little League (BLL) has been selected to host the Little League Minors State Tournament in 2023. The Minors division is for teams of 8-10 year olds, and it is set to take place from July 28 through August 2, 2023. Hosting a state tournament is an honorable and expensive venture for any Little League organization. BLL has been approved ([March 27, 2023 City Commission Meeting](#)) to hold a special event as they plan to host many families and have additional items available that far exceed a standard field rental permit.

As described in the attached letter from BLL, permanent field modifications to Field #2 and Palmieri Field at Kenning Park were proposed and desired to have in place for the Minors State Tournament and beyond for future field rentals and their usage:

- (4) dugout shade covers to help protect players from the elements, namely heat from the sun. These would require a fair amount of modifications to the current dugout fencing, including the addition of cross rails to help support the covers.
- (2) electrical outlets in the existing dugout storage areas. This feature was discussed and planned for during field construction as an alternate but removed from project award in 2019 as a cost saving measure at the time. *The Department of Public Services (DPS) has since budgeted and planned for this enhancement and the electrical was recently installed at both fields*
- (4) permanent pitching "bullpen" areas in foul territory within the current field fencing (adjacent to the field of play). These areas would each have a mound and plate



surrounded by infield mix. *The DPS does not approve this item and is therefore reflected in the agreement as not approved.*

BLL would assume all liability and would be entirely responsible for the purchase, installation, any necessary maintenance (including checking the shade covers after storm events), as well as offsite storage for the shade covers. All work would be completed under City supervision.

**LEGAL REVIEW:**

The City Attorney has reviewed the agreement with Birmingham Little League and has no objections to form or content.

**FISCAL IMPACT:**

Electrical improvements were completed this past April as part of a planned for and budgeted project totaling \$7,680. The City planned for and budgeted to add electrical outlets into the dugout storage areas on Field #2 and Palmieri Field, and in doing so prepped the area during field construction back in 2019.

The City has not budgeted for field modifications other than the electrical, and as such the BLL is entirely fiscally responsible for the shade covering improvements. Thus no additional fiscal burdens would be seen by the City in relation to this agreement.

**PUBLIC COMMUNICAITONS:**

N/A

**SUMMARY:**

The DPS enjoys our relationship and works to accommodate BLL and their requests. The City believes the addition of shade covers in addition to the City installed electricity closer to the fields is advantageous for all field users. Shade coverings were anticipated to be an additional needed improvement at some point in the future, even though they were removed from the original development of the fields that were completed in 2019.

Initial discussions with BLL about the construction of the fields in 2019 did not include bullpen areas, and did not include specs for permanent installation of mounds and plates in foul territory. Therefore, bullpens are not approved by the city and the appended agreement reflects this.

The DPS will oversee the work done by an agreed upon contractor, that will obtain all required insurances and permits necessary to perform the installation of the four (4) shade coverings over the players benches. Birmingham Little League is to procure the shade coverings, maintain them after wind and storm events, and store them in the off-season.

The attached agreement between the City and BLL reflects the desires of both parties in order to accomplish the improvements of shade coverings over players benches at Field #2 and Palmeri Field at Kenning Park.

The BLL proposal went to the Parks and Recreation Board at their February 7, 2023 meeting for comment and feedback as well. Overall, comments and feedback from the Parks and Recreation Board were supportive of the improvements that DPS agrees to have completed.

**ATTACHMENTS:**

1. The Agreement between the City and Birmingham Little League
2. Birmingham Little League Proposal dated 1/30/23

**SUGGESTED COMMISSION ACTION:**

Make a motion adopting a resolution to approve the Agreement with Birmingham Little League. In addition, to authorize the Mayor and Clerk to sign the agreement on behalf of the City.

**THE BIRMINGHAM LITTLE LEAGUE AGREEMENT  
FOR FACILITY IMPROVEMENTS**

**THIS AGREEMENT** is entered into this \_\_\_\_ day of \_\_\_\_\_, 2023 by and between the **CITY OF BIRMINGHAM**, whose address is 151 Martin Street, Birmingham, MI 48009 (hereinafter referred to as the City) and **BIRMINGHAM LITTLE LEAGUE**, whose address is P.O. Box 2536, Birmingham, Michigan 48012, (hereafter referred to as “BLL”) and the foregoing shall collectively be referred to as the parties.

**WHEREAS**, BLL has approached the City and the representatives from the Department of Public Services (“DPS”) to engage in good faith discussions about field improvements to Kenning Park, in particular field #2 and Palmeri Field (“Fields”) in advance of the 2023 Birmingham Little League season which starts in April and the Little League Minor State Tournament taking place from July 27, 2023 through August 2, 2023 (“State Tournament”); and,

**WHEREAS**, hosting the State Tournament is believed to be a once in a generation opportunity for BLL, and, therefore, are desirous for this event to have, what they believe to be, needed improvements; and,

**WHEREAS**, the representatives of BLL and DPS have been in discussions regarding the installation of dugout covers, electricity to the field and bullpen mounds.

**NOW, THEREFORE**, in consideration of the foregoing preambles, the adequacy of which is acknowledged by and between the parties to this Agreement, the parties agree as follows:

1. **DUGOUT COVERS:**

A. It is agreed to that the BLL will purchase the dugout covers and is completely financially and physically responsible for the installation, maintenance, and storage offsite during the off season, which is approximately October through March or until the season begins each year, of all four dugout covers which are to be located over the players’ benches located on Field #2, which involves two covers and two covers for the Palmeri Field. The physical responsibility and financial responsibility will include making sure the covers are properly secured and repaired or replaced after any and all storm or wind events which alters or changes the dugout covers.

B. The BLL is responsible financially and physically to provide all necessary ordering information such as measurements and specifications to the City via its DPS Department in advance of placing any order for the City’s review and approval.

C. The BLL is to provide to the DPS Department all schedules, work and plans in advance regarding the installation and/or maintenance of the covers to DPS. The DPS will always maintain oversight and inspection regarding the installation and all approvals are necessary before installation and continues throughout the life of the

dugout covers and the City, through its DPS, reserves the right to stop or change the work should any correction be necessary. All matters regarding dugout covers will be upon the approval and acceptance of DPS, Engineering or Building Departments.

2. **ELECTRICITY:** The City is presently pursuing electrical service to the Fields. The electrical work was previously budgeted and planned for the Fields. Therefore, BLL will be able to enjoy electricity being provided to the Fields without any cost to the BLL.

3. **BULLPEN MOUNDS:** While the BLL would like the placement of bullpens for enhancement to the fields for the State Tournament and beyond, the City will not agree to bullpen mounds due to concerns for safety issues of anyone utilizing the fields. The fields are located in the City of Birmingham for the enjoyment of all people and, therefore, the City does not agree to nor consent to bullpen mounds being placed in the City fields.

4. **TERM:** This Agreement shall have a term of 10 years from the date stated above, and is renewable upon expiration for 6 month terms. The City shall have the right to unilaterally terminate this Agreement, with or without cause, on thirty (30) days written notice. In the event of termination, the BLL shall receive compensation for services up to the date the termination takes effect and the City shall be entitled to retain and use the results of all services, goods and information prepared by the BLL through such date.

5. **FEES:** The fees for this entire project, except electricity to the fields, shall be borne solely by BLL.

6. **GOOD MORAL CHARACTER:** BLL shall employ personnel of good moral character and fitness in performing all services under this Agreement.

7. **INSURANCE SUBMISSION REQUIREMENTS:** The BLL has submitted proof to the City that it meets all City insurance requirements. Insurance, with coverage amounts at no less than the City's minimum requirements, must be held by the BLL throughout the term of this Agreement. Certificates of insurance as stated below will be required no later than five (5) business days from the date of the BLL's acceptance of the terms of this Agreement.

8. **CONFIDENTIAL AND OR PROPRIETARY INFORMATION:** The BLL acknowledges that in performing services pursuant to this Agreement, certain confidential and/or proprietary information (including, but not limited to, internal organization, methodology, personnel and financial information, etc.) may become involved. The BLL recognizes that unauthorized exposure of such confidential or proprietary information could irreparably damage the City. Therefore, the BLL agrees to use reasonable care to safeguard the confidential and proprietary information and to prevent the unauthorized use or disclosure thereof. The BLL shall inform its employees of the confidential or proprietary nature of such information and shall limit access thereto to employees

rendering services pursuant to this Agreement. The BLL further agrees to use such confidential or proprietary information only for the purpose of performing services pursuant to this Agreement.

9. **INDEPENDENT:** The BLL and the City agree that the BLL is acting as an independent contractor with respect to the BLL's role in providing services to the City pursuant to this Agreement, and as such, shall be liable for its own actions and neither the BLL nor its employees shall be construed as employees of the City. Nothing contained in this Agreement shall be construed to imply a joint venture or partnership and neither party, by virtue of this Agreement, shall have any right, power or authority to act or create any obligation, express or implied, on behalf of the other party, except as specifically outlined herein. Neither the City nor the BLL shall be considered or construed to be the agent of the other, nor shall either have the right to bind the other in any manner whatsoever, except as specifically provided in this Agreement, and this Agreement shall not be construed as a contract of agency. The BLL shall not be considered entitled or eligible to participate in any benefits or privileges given or extended by the City, or be deemed an employee of the City for purposes of federal or state withholding taxes, FICA taxes, unemployment, workers' compensation or any other employer contributions on behalf of the City.

10. **COMPLIANCE WITH LAWS:** The BLL agrees to fully and faithfully carry out the duties of set forth herein using its best efforts in accomplishing all assignments from the City, and further, in addition to upholding all federal, and state laws and applicable codes of professional conduct to which the BLL is subject, the BLL hereby agrees to be bound by all Federal, State, or City of Birmingham ordinances, rules, regulations and policies as are amended from time to time, and including without limitation the Fair Labor Standards Act, the Equal Employment Opportunity rules and regulations, the Transportation Safety Act and the Occupational Safety and Health Acts.

11. **NON-COMPLIANCE WITH INSURANCE REQUIREMENTS:** Failure to deliver and maintain insurance in accordance with the terms of this Agreement will be cause for the City, by and through its City Manager, to terminate this Agreement, or at the City's option, the City may purchase on the open market such required insurance and shall be entitled to charge any additional cost to the BLL, either by offset to any amounts due and owing the BLL for services provided to the City, or, by separate bill and demand for payment. Nothing in this paragraph shall be deemed to create or be interpreted as establishing a "for cause" termination; the BLL agrees and understands that its engagement is at will and may be terminated by the City Manager for any cause or no cause.

12. **INDEMNIFICATION:** To the fullest extent permitted by law, the BLL and any entity or person for whom the BLL is legally liable, agrees to be responsible for any liability, defend, pay on behalf of, indemnify, and hold harmless the City of Birmingham, its elected and appointed officials, employees and volunteers and others working on their behalf against any and all claims, demands, suits, or loss, including all costs and reasonable attorney fees connected therewith, and for any damages which may be

asserted, claimed or recovered against or from the City, its elected and appointed officials, employees, volunteers or others working on their behalf, by reason of personal injury, including bodily injury and death and/or property damage, including loss of use thereof, which arise out of the acts, errors or omissions of the BLL including its employees and agents, in the performance of this Agreement. Such responsibility shall not be construed as liability for damage caused by or resulting from the sole act or omission of its elected or appointed officials, employees, volunteers or others working on behalf of the City.

13. **STANDARD INSURANCE REQUIREMENTS:** The BLL shall assure that its contractors maintain the following insurance during the life of this Agreement and obtain proof for the applicable types of insurance coverage and minimum limits as set forth below:

A. Workers' Compensation Insurance:

For Non-Sole Proprietorships: The Contractor shall procure and maintain during the life of this Agreement, Workers' Compensation Insurance, including Employers Liability Coverage, in accordance with all applicable statutes of the State of Michigan.

For Sole Proprietorships: The Contractor shall complete and furnish to the City prior to the commencement of work under this Agreement a signed and notarized Sole Proprietor Form, for sole proprietors with no employees or with employees, as the case may be.

B. Commercial General Liability Insurance: The Contractor shall procure and maintain during the life of this Agreement, Commercial General Liability Insurance on an "Occurrence Basis" with limits of liability not less than **\$1,000,000** per occurrence combined single limit, Personal Injury, Bodily Injury and Property Damage. Coverage shall include the following extensions: (A) Contractual Liability; (B) Products and Completed Operations; (C) Independent Coverage; (D) Broad Form General Liability Extensions or equivalent; (E) Deletion of all Explosion, Collapse and Underground (XCU) Exclusions, if applicable.

C. Motor Vehicle Liability: The Contractor shall procure and maintain during the life of this Agreement Motor Vehicle Liability Insurance, including all applicable no-fault coverages, with limits of liability of not less than \$1,000,000 per occurrence combined single limit Bodily Injury and Property Damage. Coverage shall include all owned vehicles, all non-owned vehicles, and all hired vehicles.

D. Additional Insured: Commercial General Liability and Motor Vehicle Liability Insurance, as described above, shall include an endorsement stating the following Additional Insureds: The City of Birmingham, including all elected and appointed officials, all employee and volunteers, all boards,

**commissions and/or authorities and board members, including employees and volunteers thereof.** This coverage shall be primary to any other coverage that may be available to the additional insured, whether any other available coverage by primary, contributing or excess.

E. Professional Liability: If applicable, professional liability insurance with limits of not less than \$2,000,000 per claim if the Contractor will provide services that are customarily subject to this type of coverage.

F. Coverage Expiration: If any of the above coverages expire during the term of this Agreement, the Contractor shall deliver renewal certificates and/or policies to the City at least (10) days prior to the expiration date.

G. Proof of Insurance Coverage: The Contractor shall provide the City of Birmingham at the time the Agreement is returned for execution, Certificates of Insurance and/or policies, acceptable to the City of Birmingham, as listed below.

- 1) Two (2) copies of Certificate of Insurance for Workers' Compensation Insurance, or a signed and notarized copy of the Sole Proprietor Form;
- 2) Two (2) copies of Certificate of Insurance for Commercial General Liability Insurance;
- 3) Two (2) copies of Certificate of Insurance for Vehicle Liability Insurance;
- 4) Two (2) copies of Certificate of Insurance for Professional Liability Insurance, if applicable;
- 5) If so requested, Certified Copies of all policies mentioned above will be furnished.

H. Maintaining Insurance: Upon failure of the Contractor to obtain or maintain such insurance coverage for the term of the Agreement, the City of Birmingham may, at its option, purchase such coverage and subtract the cost of obtaining such coverage from the Agreement amount. In obtaining such coverage, the City of Birmingham shall have no obligation to procure the most cost-effective coverage but may contract with any insurer for such coverage.

14. **WRITTEN NOTICES**: Written notices regarding this Agreement shall be addressed to the following:

City: City of Birmingham  
P.O. Box 3001  
Birmingham, Michigan 48012  
Attn: Carrie Laird, Parks & Recreation Manager

League: BLL  
P.O. Box 2536  
Birmingham, Michigan 48012  
Attention: Andrew M. Harris, Esq., President

15. **COVID:** The Contractor shall follow all of the City's COVID-19 safety protocols while on City property. Additionally, the Contractor staff which will be in physical contact with city staff must have current vaccinations against COVID-19. The City, at its discretion, may ask for proof of vaccination of the Contractor's staff. Failure to provide proof of vaccination when requested will cause the City to request un-vaccinated personnel to leave, request alternate staff, and if the Contractor is unable to comply, this violation of safety protocols will constitute a breach of contract by the Contractor.

16. **AMENDMENTS:** No amendment, modification or supplement to this Agreement shall be binding unless it is in writing and signed by authorized representatives of the parties.

17. **WAIVER OF BREACH:** No waiver by either party of any breach of any of the terms, covenants or conditions herein contained by the other party shall be construed as a waiver of any succeeding breach of this same or of any other term, covenant or condition.

18. **COMPLETE AGREEMENT:** The parties agree that the conditions set forth in this Agreement sets forth all terms and conditions of the BLL's agreement with the City of Birmingham. This Agreement supersedes all prior agreements or understandings between the parties. There are no promises, conditions or understandings other than those stated herein, and, that any prior negotiations, terms or conditions discussed between the City and the BLL shall not constitute a part of this Agreement. The term "agreement" as used in this clause shall include any future written amendments, modifications, or supplements made in accordance herewith.

19. **DIRECT OR INDIRECT INTEREST:** If, after the effective date of this Agreement, any official of the City, or spouse, child, parent or in-law of such official or employee shall become directly or indirectly interested in this Agreement or the affairs of the BLL, the City shall have the right to terminate this Agreement without further liability to the BLL if the disqualification has not been removed within thirty (30) days after the City has given the BLL notice of the disqualifying interest. Ownership of less than one percent (1%) of the stock or other equity interest in a corporation or partnership shall not be a disqualifying interest. Employment shall be a disqualifying interest.

20. **FAILURE TO PERFORM.** If the BLL fails to perform its obligations hereunder, the City may take any and all remedial actions provided by the general specifications or otherwise permitted by law.



21. **LEGAL PROCEEDINGS:** Any controversy or claim arising out of or relating to this Agreement, or the breach thereof, shall be settled either by commencement of a suit in Oakland County Circuit Court, the 48<sup>th</sup> District Court or by arbitration. If both parties elect to have the dispute resolved by arbitration, it shall be settled pursuant to Chapter 50 of the Revised Judicature Act for the State of Michigan and administered by the American Arbitration Association with one arbitrator being used, or three arbitrators in the event any party's claim exceeds \$1,000,000. Each party shall bear its own costs and expenses and an equal share of the arbitrator's and administrative fees of arbitration. Such arbitration shall qualify as statutory arbitration pursuant to MCL §600.5001 et seq., and the Oakland County Circuit Court or any court having jurisdiction shall render judgment upon the award of the arbitrator made pursuant to this Agreement. The laws of the State of Michigan shall govern this Agreement, and the arbitration shall take place in Oakland County, Michigan. In the event that the parties elect not to have the matter in dispute arbitrated, any dispute between the parties may be resolved by the filing of a suit in a federal or state court with jurisdiction over Oakland County, Michigan.

**IN WITNESS WHEREOF**, the parties hereto agree to be bound by the above terms and conditions, and the BLL, by its authorized signature below, expressly accepts this Agreement upon the above provided terms and conditions contained in this Agreement as of the date first above written.

BIRMINGHAM LITTLE LEAGUE

By: [Signature]  
Andrew M. Harris, President

STATE OF MICHIGAN )  
 ) ss:  
COUNTY OF OAKLAND )

On this 1st day of May, 2023, before me personally appeared Andrew M. Harris, President who acknowledged that with authority on behalf of the Birmingham Little League to do so he/she signed this Agreement.

[Signature]  
Notary Public  
Wayne County, Michigan  
Acting in Oakland County, Michigan  
My commission expires: 10/05/2023

LISA RANDAZZO-SMITH  
NOTARY PUBLIC, STATE OF MI  
COUNTY OF WAYNE  
MY COMMISSION EXPIRES Oct 5, 2023  
ACTING IN COUNTY OF Oakland

**CITY OF BIRMINGHAM:**

By: \_\_\_\_\_  
Therese Longe, Mayor

By: \_\_\_\_\_  
Alexandria D. Bingham, City Clerk

**APPROVED:**

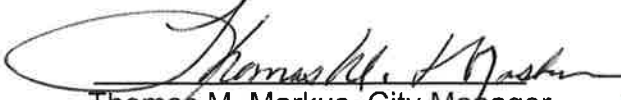
  
Thomas M. Markus, City Manager  
(Approved as to substance)

  
Scott D. Zielinski, Director of Public  
Services  
(Approved as to substance)

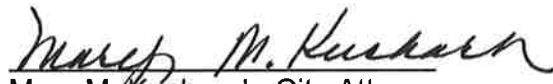
  
Mary M. Kucharek, City Attorney  
(Approved as to form)

# Birmingham Little League

January 30, 2023

**VIA E-MAIL ONLY**

Ms. Carrie Laird  
City of Birmingham-Department of Public Services  
Parks Manager  
851 S. Eton  
Birmingham, MI 48009

**RE: Proposal Between the City of Birmingham Department of Public Services and Birmingham Little League**

Dear Ms. Laird:

Since the summer of 2022, representatives from the Department of Public Services (“DPS”) and Birmingham Little League (“BLL”) engaged in good-faith discussions about field improvements to Kenning Park (in particular Field #2 and Palmeri Field (“Fields”)) in advance of the 2023 BLL season in April as well as the Little League Minors State Tournament, taking place from July 27<sup>th</sup> through August 2<sup>nd</sup> (“State Tournament”). Hosting the State Tournament is a once-in-a-generation opportunity for BLL, an event which is fueling some of these needed improvements.

As you know, the talked-about improvements included Dugout Covers on the Fields (“Covers”), powering additional electricity and installation of bullpen mounds/plates (“Bullpens”). During these discussions, BLL understood it would be financially responsible for the improvements (but for the electricity) due in part to DPS’s previously approved budget which did not include these items.

Initially, the aforementioned discussions produced a plan wherein DPS would negotiate directly with a vendor(s) to procure and install the Covers while BLL would prepare a site plan to request the Bullpens. Recently, however, DPS underwent significant staffing changes which upended this plan.

On January 11<sup>th</sup>, we spoke about a viable alternative wherein the Covers and Bullpens could be subject to a separate agreement between DPS and BLL. To move forward with this approach and increase the chance the aforementioned improvements could occur before the 2023 season, you politely suggested I prepare the following written proposal for consideration by DPS as well as the Parks & Recreation Board during its February 7<sup>th</sup> meeting.

## **A. DUGOUT COVERS**

The initial discussions included a decision to procure Covers from Beacon Athletics which mirrored the ones at Keith Park in West Bloomfield Township. In fact, you spoke with Chris Frey from West Bloomfield in early October, 2022, who in turn provided information about the Covers’ measurements, maintenance and durability.

# Birmingham Little League

In exchange for DPS providing BLL the necessary authority, it is willing to procure the Covers, facilitate their installation, provide the necessary maintenance (including after weather events), oversee set-up/take down each season and provide offsite storage.

## B. ELECTRICITY

While our discussion on the improvements went through many changes, the initial plan wherein the City completes the due diligence necessary to run additional electricity to Kenning (and ensures the electricity is installed before the 2023 season) at its own cost in advance of the 2023 season remains.

## C. BULLPEN MOUNDS

The Bullpens will be a key enhancement for the 2023 season, the State Tournament and beyond. There will be four (4) separate Mound set-ups (one each in foul territory (but on the field side of the fences) on Field #2 and Palmeri), which will include a dirt area for pitchers, a pitcher's mound, a dirt area for a home plate and the home plate itself. The distance from the back of the mound to the plate will be roughly fifty (50) feet and start approximately twenty five (25) feet behind where the base coaches stand (please see the enclosed diagram marked as **Exhibit A**). BLL will install the Mounds, maintain them throughout the year and store them in the offseason.

I look forward to further discussion with DPS about this proposal. As you know, the prompt implementation of these improvements are important to BLL, the families it serves and the guests it will host throughout Michigan during the State Tournament.

Sincerely,

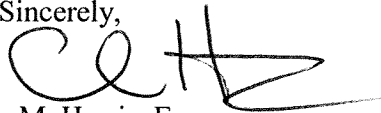

Andrew M. Harris, Esq.

President

Birmingham Little League

Enclosure

cc: Patrick O'Neill (via e-mail w/encl.)  
David Palmeri (via e-mail w/encl.)  
Wendy McIntyre Peard, Esq. (via e-mail w/encl.)

# **EXHIBIT A**

# KENNING PARK BALL FIELD CONSTRUCTION

CITY OF BIRMINGHAM - BIRMINGHAM, MICHIGAN

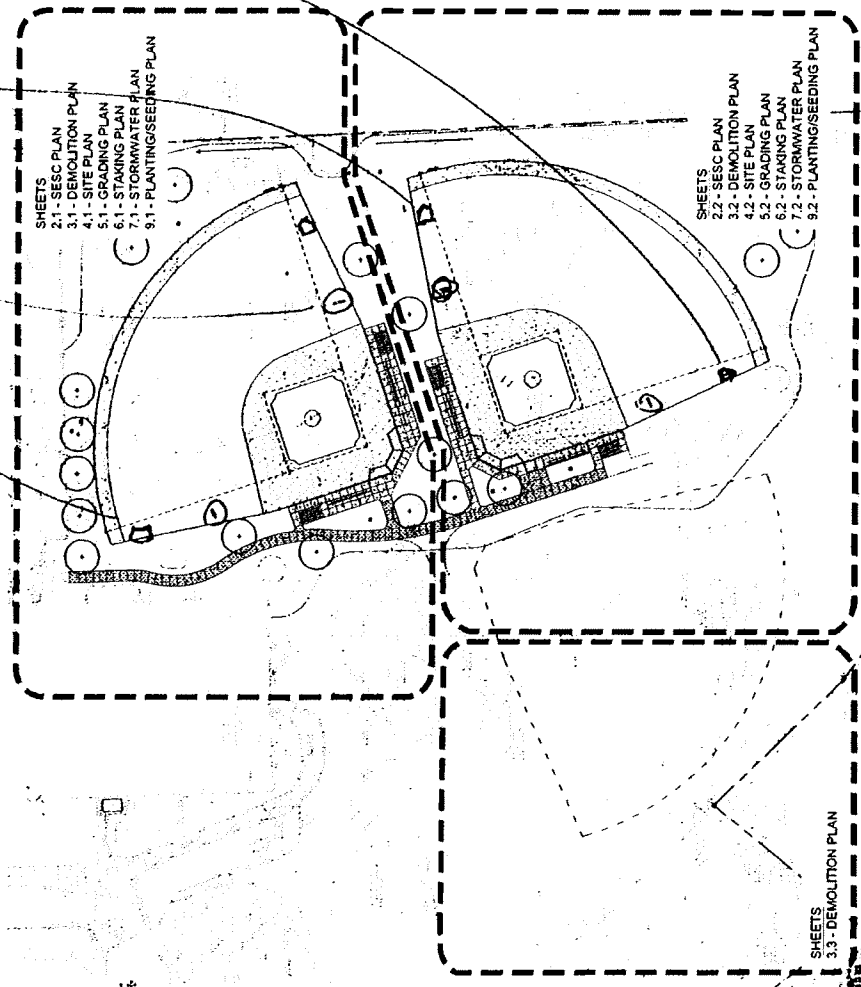

### SHEET INDEX:

- SHEET 1: COVER SHEET
- SHEET 2.1, 2.2: SESC PLAN
- SHEET 2.3: SESC NOTES & DETAILS
- SHEET 3.1, 3.2, 3.3: DEMOLITION PLAN
- SHEET 4.1, 4.2: SITE PLAN
- SHEET 5.1, 5.2: GRADING PLAN
- SHEET 6.1, 6.2: STAKING PLAN
- SHEET 7.1, 7.2: STORMWATER PLAN
- SHEET 8: IRRIGATION PLAN
- SHEET 9.1, 9.2: PLANTING AND SEEDING PLAN
- SHEET 10: CONSTRUCTION DETAILS
- SHEET 11: CONSTRUCTION DETAILS
- SHEET 12: CONSTRUCTION DETAILS
- SHEET 13: CONSTRUCTION DETAILS
- SHEET 14: CONSTRUCTION DETAILS
- SHEET 15: CONSTRUCTION DETAILS
- SHEET 16: CONSTRUCTION DETAILS
- SHEET 17: ELECTRICAL SYMBOLS AND INDEX
- SHEET E0.0: ELECTRICAL PLAN
- SHEET E1.0: ELECTRICAL PLAN

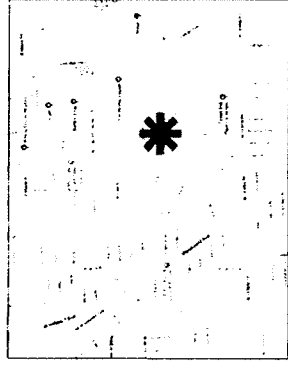

LOCATION MAP - NOT TO SCALE

- CONTRACTOR RESPONSIBILITIES THROUGHOUT THE PROJECT**
- THE CONTRACTOR SHALL BE RESPONSIBLE FOR CONTACTING AND COORDINATING WITH ALL UTILITIES TO DETERMINE THE DEPT. OF PUBLIC WORKS RECORDS TO IDENTIFY ALL UTILITIES TO BE MAINTAINED OR REMOVED. THE CONTRACTOR SHALL ASSUME SOLE RESPONSIBILITY FOR ANY COST INCURRED DUE TO DAMAGE OF ANY UTILITIES.
  - THE CONTRACTOR SHALL NOT WILLFULLY PROCEED WITH THE CONSTRUCTION AS DEFINED BY THE CONSTRUCTION DOCUMENTS UNLESS THE CONTRACTOR HAS THE ATTENTION OF THE LANDSCAPE ARCHITECT. THE CONTRACTOR SHALL ASSUME FULL RESPONSIBILITY FOR ALL NECESSARY REVISIONS DUE TO FAILURE TO OBTAIN SUCH NOTIFICATION.
  - ANY DISCREPANCIES BETWEEN DIMENSIONED LAYOUT AND ACTUAL FIELD CONDITIONS OR OBTAINING EXISTING CONDITIONS SHALL BE THE RESPONSIBILITY OF THE ARCHITECT/OWNER. THE CONTRACTOR SHALL ASSUME FULL RESPONSIBILITY FOR ALL NECESSARY REVISIONS DUE TO FAILURE TO OBTAIN SUCH NOTIFICATION.
  - THE CONTRACTOR SHALL BE RESPONSIBLE FOR ANY COORDINATION WITH SUBCONTRACTORS AS REQUIRED TO ACCOMPLISH CONSTRUCTION INSTALLATION OPERATIONS.
  - THE CONTRACTOR SHALL PROVIDE AND MAINTAIN POSITIVE SURFACE DRAINAGE.
  - THE CONTRACTOR SHALL BE RESPONSIBLE FOR ANY SETTING OF MARKS, PINS, AND DAMAGED DURING CONSTRUCTION, INCLUDING BUT NOT LIMITED TO IRRIGATION, LIGHTS AND SIGNALS.



KENNING PARK BALL FIELD  
CONSTRUCTION  
CITY OF BIRMINGHAM  
BIRMINGHAM, MICHIGAN



DATE	REVISION
11/15/17	1.0 - INITIAL
11/15/17	1.1 - REVISION
11/15/17	1.2 - REVISION
11/15/17	1.3 - REVISION
11/15/17	1.4 - REVISION
11/15/17	1.5 - REVISION
11/15/17	1.6 - REVISION
11/15/17	1.7 - REVISION
11/15/17	1.8 - REVISION
11/15/17	1.9 - REVISION
11/15/17	1.10 - REVISION
11/15/17	1.11 - REVISION
11/15/17	1.12 - REVISION
11/15/17	1.13 - REVISION
11/15/17	1.14 - REVISION
11/15/17	1.15 - REVISION
11/15/17	1.16 - REVISION
11/15/17	1.17 - REVISION
11/15/17	1.18 - REVISION
11/15/17	1.19 - REVISION
11/15/17	1.20 - REVISION
11/15/17	1.21 - REVISION
11/15/17	1.22 - REVISION
11/15/17	1.23 - REVISION
11/15/17	1.24 - REVISION
11/15/17	1.25 - REVISION
11/15/17	1.26 - REVISION
11/15/17	1.27 - REVISION
11/15/17	1.28 - REVISION
11/15/17	1.29 - REVISION
11/15/17	1.30 - REVISION
11/15/17	1.31 - REVISION
11/15/17	1.32 - REVISION
11/15/17	1.33 - REVISION
11/15/17	1.34 - REVISION
11/15/17	1.35 - REVISION
11/15/17	1.36 - REVISION
11/15/17	1.37 - REVISION
11/15/17	1.38 - REVISION
11/15/17	1.39 - REVISION
11/15/17	1.40 - REVISION
11/15/17	1.41 - REVISION
11/15/17	1.42 - REVISION
11/15/17	1.43 - REVISION
11/15/17	1.44 - REVISION
11/15/17	1.45 - REVISION
11/15/17	1.46 - REVISION
11/15/17	1.47 - REVISION
11/15/17	1.48 - REVISION
11/15/17	1.49 - REVISION
11/15/17	1.50 - REVISION
11/15/17	1.51 - REVISION
11/15/17	1.52 - REVISION
11/15/17	1.53 - REVISION
11/15/17	1.54 - REVISION
11/15/17	1.55 - REVISION
11/15/17	1.56 - REVISION
11/15/17	1.57 - REVISION
11/15/17	1.58 - REVISION
11/15/17	1.59 - REVISION
11/15/17	1.60 - REVISION
11/15/17	1.61 - REVISION
11/15/17	1.62 - REVISION
11/15/17	1.63 - REVISION
11/15/17	1.64 - REVISION
11/15/17	1.65 - REVISION
11/15/17	1.66 - REVISION
11/15/17	1.67 - REVISION
11/15/17	1.68 - REVISION
11/15/17	1.69 - REVISION
11/15/17	1.70 - REVISION
11/15/17	1.71 - REVISION
11/15/17	1.72 - REVISION
11/15/17	1.73 - REVISION
11/15/17	1.74 - REVISION
11/15/17	1.75 - REVISION
11/15/17	1.76 - REVISION
11/15/17	1.77 - REVISION
11/15/17	1.78 - REVISION
11/15/17	1.79 - REVISION
11/15/17	1.80 - REVISION
11/15/17	1.81 - REVISION
11/15/17	1.82 - REVISION
11/15/17	1.83 - REVISION
11/15/17	1.84 - REVISION
11/15/17	1.85 - REVISION
11/15/17	1.86 - REVISION
11/15/17	1.87 - REVISION
11/15/17	1.88 - REVISION
11/15/17	1.89 - REVISION
11/15/17	1.90 - REVISION
11/15/17	1.91 - REVISION
11/15/17	1.92 - REVISION
11/15/17	1.93 - REVISION
11/15/17	1.94 - REVISION
11/15/17	1.95 - REVISION
11/15/17	1.96 - REVISION
11/15/17	1.97 - REVISION
11/15/17	1.98 - REVISION
11/15/17	1.99 - REVISION
11/15/17	2.00 - REVISION



1



**LANDSCAPE ARCHITECT:**  
JOHNSON HILL LAND ETHOS STUDIO  
CONTACT: MARK ROBINSON  
412 LONGSHORE DRIVE  
ANN ARBOR, MICHIGAN 48105  
PHONE: 734.668.7416  
EMAIL: mrobinson@the-studio.com

**OWNER:**  
CITY OF BIRMINGHAM  
CONTACT: LAUREN WOOD  
851 S. ETON STREET  
BIRMINGHAM, MICHIGAN 48009  
PHONE: 246.530.1702  
EMAIL: lwood@bhamgov.org

**PROJECT ADDRESS:**  
2300 E. LINCOLN STREET  
BIRMINGHAM, MICHIGAN 48009



# MEMORANDUM

Police Department

**DATE:** April 26, 2023

**TO:** Thomas M. Markus, City Manager

**FROM:** Chris Koch, Investigative Captain

**APPROVED:** Scott A. Grewe, Chief of Police

**SUBJECT:** Old Woodward Ventures, LLC doing business at Luxe Requests a transfer of membership in the Class C and SDM License with Sunday Sales (PM) and Outdoor Service Area located at 525 N Old Woodward, Birmingham, Oakland County, MI from 50% Lawrence Bongiovanni Trust and 50% Eunice Bongiovanni to 33.34% Kara Bongiovanni Living Trust, 33.33% Lawrence and Amy Bongiovanni Living Trust and 33.33% Joseph Bongiovanni.

---

## INTRODUCTION:

The police department received a request from the Law Offices of Adkison, Need, Allen, and Rentrop for a transfer of membership in Old Woodward Ventures, LLC. doing business at Luxe. Luxe is a Class C and SDM liquor licensed entity which operates with Sunday Sales (PM) and an Outdoor Service Area permit located at 525 N Old Woodward, Birmingham, Oakland County, MI 48009. Old Woodward Ventures, LLC has paid the initial fee of \$1500.00 for a business that serves alcoholic beverages for consumption on the premises per section 7.33 of the Birmingham City Code. Old Woodward Ventures, LLC, is comprised of two members:

<u>Members</u>	<u>Membership</u>
Lawrence Bongiovanni Living Trust	50%
Eunice Bongiovanni Living Trust	50%

Old Woodward Ventures, LLC, pursuant to the last Will and Testament of Lawrence Bongiovanni and Eunice Bongiovanni, all their property was poured over to their Living Trust. The membership of Old Woodward Ventures, LLC is owned by Lawrence Bongiovanni, Trust, Kara Bongiovanni Trustee 50%, and Eunice Bongiovanni, Trust, Kara Bongiovanni Trustee 50%.

Chapter 10 (Alcoholic Liquors), Section 42 of the Birmingham City Code requires that “any and all transfers of a liquor license for consumption of intoxicating liquor on premises require the approval of the City Commission of any kind including, but not limited to ownership of the license; stock in a corporation that owns a license; interest in a license through any entity; or location of the licensed premises.” In this case, the interest in the license through an entity is the reason this issue is coming before the City Commission.

**BACKGROUND:**

On May 5, 2019, member Lawrence Bongiovanni passed away. Pursuant to the Last Will and Testament of Lawrence Bongiovanni, all his property is poured over to his Living Trust. Lawrence Bongiovanni was the Trustee of his Trust and his successor Trustee was his wife Eunice Bongiovanni.

On November 15, 2020, stockholder Eunice Bongiovanni passed away. Pursuant to the Last Will and Testament of Eunice Bongiovanni, all her property was poured over to her Living Trust. Eunice Bongiovanni was the Trustee of Eunice’s Trust and her successor Trustee was her daughter Kara Bongiovanni.

Eunice Bongiovanni Trust will assign 16.67% membership interest to Kara Bongiovanni Living Trust, 16.665% membership interest to Lawrence and Amy Bongiovanni Living Trust, and 16.665% membership interest to Joseph Bongiovanni.

Lawrence Bongiovanni, Trust will assign 16.67% membership interest to Kara Bongiovanni Living Trust, 16.665% membership interest to Lawrence and Amy Bongiovanni Living Trust, and 16.665% membership interest to Joseph Bongiovanni.

Upon completion of this application, the ownership of Old Woodward Ventures, LLC will be as follows:

<u>Member</u>	<u>Membership</u>
Kara Bongiovanni Living Trust	33.34%
Lawrence and Amy Bongiovanni Living Trust	33.33%
Joseph Bongiovanni	33.33%

The current hours of operation will remain the same, 11:00 am to 11:00 pm Sundays-Tuesdays and 11:00 am to midnight Wednesday-Saturday. There are no changes to the capacity or layout of the restaurant. There are no changes in the Special Land Use Permit (SLUP).

A background check was conducted on Kara Bongiovanni, Lawrence Bongiovanni, Amy Bongiovanni, and Joseph Bongiovanni using the Law Enforcement Information Network (LEIN), the Court’s Law Enforcement Management Information System (CLEMIS), and the Middle Atlantic-Great Lakes Organized Crime Law Enforcement Network (MAGLOCLLEN) FBI N-DEX national database. No negative information was uncovered.

It should be noted that on November 21, 2014, Luxe was cited by the Birmingham Police Department for furnishing alcoholic liquor to a person under the age of twenty-one (21) as part

of the department’s undercover liquor license decoy program. The Michigan Liquor Control Commission (MLCC) issued a fine to Luxe in the amount of \$700.00 on March 10, 2015.



**LEGAL REVIEW:**

Non-applicable

**FISCAL IMPACT:**

\$1,500.00 liquor license application fee received.

**PUBLIC COMMUNICATIONS:**

Non-applicable

**SUMMARY:**

Old Woodward Ventures, LLC is requesting a transfer of its membership interest in doing business as Luxe. Old Woodward Ventures, LLC holds the Class C and SDM License with Sunday Sales (PM) and Outdoor Service Area located at 525 N Old Woodward, Birmingham, Oakland County, MI, and is requesting that the 50% membership interest owned by Lawrence Bongiovanni Living Trust be transferred and divided among Kara Bongiovanni Living trust, Lawrence and Amy Bongiovanni Living Trust and Joseph Bongiovanni. The 50% membership interest owned by Eunice Bongiovanni Living Trust is to be transferred and divided among Kara Bongiovanni Living Trust, Lawrence and Amy Bongiovanni Living Trust, and Joseph Bongiovanni. The applicants, Amy Bongiovanni, Lawrence and Amy Bongiovanni, and Joseph Bongiovanni, have successfully completed the police background check. The current SLUP in place for Luxe is in the name of Old Woodward Ventures, LLC this will not change. The police department has not uncovered any information that would give cause to deny the applicant's request.

**SUGGESTED COMMISSION ACTION:**

Make a motion adopting a resolution to authorize the City Clerk to complete the Local Approval Notice at the request of Old Woodward Ventures, LLC to approve the request of Lawrence and Eunice's Living Trusts to transfer the membership of Old Woodward Ventures, LLC which is owned by Lawrence Bongiovanni, Trust, Kara Bongiovanni Trustee 50% and Eunice Bongiovanni, Trust Kara Bongiovanni Trustee 50%, which holds the Class C and SDM License with Sunday Sales (PM) and Outdoor Service Area located at 525 N Old Woodward, Birmingham, Oakland County, MI to 33.34% Kara Bongiovanni Living Trust, 33.33% Lawrence and Amy Bongiovanni Living Trust and 33.33% Joseph Bongiovanni.



## **MEMORANDUM**

Police Department

**DATE:** April 25, 2023

**TO:** Thomas M. Markus, City Manager

**FROM:** Chris Koch, Investigative Captain

**APPROVED:** Scott A. Grewe, Chief of Police

**SUBJECT:** Birmingham Ventures, Inc. doing business as Salvatore Scallopini Requests a transfer of shares in the Class C and SDM License with Sunday Sales (PM) and Outdoor Service Area located at 505 N Old Woodward, Birmingham, Oakland County, MI from Eunice Bongiovanni Living Trust to Kara Bongiovanni Living Trust, 170 Shares Lawrence and Amy Bongiovanni Living Trust 170 Shares and Joseph Bongiovanni 170 Shares.

---

### INTRODUCTION:

The police department received a request from the Law Offices of Adkison, Need, Allen, and Rentrop for a transfer of shares in Birmingham Ventures, Inc. doing business at Salvatore Scallopini. Salvatore Scallopini is a Class C and SDM liquor licensed entity which operates with Sunday Sales (PM) and an Outdoor Service Area permit located at 505 N Old Woodward, Birmingham, Oakland County, MI 48009. Birmingham Ventures, Inc. has paid the initial fee of \$1500.00 for a business that serves alcoholic beverages for consumption on the premises per section 7.33 of the Birmingham City Code. Birmingham Ventures, Inc. is comprised of one stockholder:

<u>Members</u>	<u>Membership</u>
Eunice Bongiovanni Living Trust	510 Shares

Birmingham Ventures, Inc. pursuant to the last Will and Testament of Eunice Bongiovanni all her property was poured over to her Living Trust. The Birmingham Ventures, Inc. stock is currently held by Eunice Bongiovanni Living Trust, Kara Bongiovanni Trustee.

Chapter 10 (Alcoholic Liquors), Section 42 of the Birmingham City Code requires that "any and all transfers of a liquor license for consumption of intoxicating liquor on premises require the approval of the City Commission of any kind including, but not limited to ownership of the license; stock in a corporation that owns a license; interest in a license through any entity; or location of

the licensed premises.” In this case, the interest in the license through an entity is the reason this issue is coming before the City Commission.

**BACKGROUND:**

On May 5, 2019, stockholder Lawrence Bongiovanni passed away. Pursuant to the Last Will and Testament of Lawrence Bongiovanni, all his property is poured over to his Living Trust. Lawrence Bongiovanni was the Trustee of his Trust and his successor Trustee was his wife Eunice Bongiovanni.

On November 15, 2020, stockholder Eunice Bongiovanni passed away. Pursuant to the Last Will and Testament of Eunice Bongiovanni, all her property was poured over to her Living Trust. Eunice Bongiovanni was the Trustee of Eunice’s Trust and her successor Trustee was her daughter Kara Bongiovanni.

Eunice Bongiovanni, Trust will assign 170 shares to Kara Bongiovanni Living Trust, 170 shares to Lawrence and Amy Bongiovanni Living Trust, and 170 shares to Joseph Bongiovanni.

Upon completion of this application, the ownership of Birmingham Ventures, Inc. will be as follows:

<u>Member</u>	<u>Membership</u>
Kara Bongiovanni Living Trust	170 Shares
Lawrence and Amy Bongiovanni Living Trust	170 Shares
Joseph Bongiovanni	170 Shares

The current hours of operation will remain the same, 1:00 pm to 10:00 pm Sundays 4:00 pm to 10 pm Monday-Thursday, 4:00 pm to 11:00 pm on Friday, and 3:00 pm to 11:00 pm on Saturday. There are no changes to the capacity or layout of the restaurant. There are no changes in the Special Land Use Permit (SLUP).

A background check was conducted on Kara Bongiovanni, Lawrence Bongiovanni, Amy Bongiovanni, and Joseph Bongiovanni using the Law Enforcement Information Network (LEIN), the Court’s Law Enforcement Management Information System (CLEMIS), and the Middle Atlantic-Great Lakes Organized Crime Law Enforcement Network (MAGLOCLLEN) FBI N-DEX national database. No negative information was uncovered.

**LEGAL REVIEW:**

Non-applicable

**FISCAL IMPACT:**

\$1,500.00 liquor license application fee received.

**PUBLIC COMMUNICATIONS:**

Non-applicable

**SUMMARY:**

Birmingham Ventures, Inc. is requesting a transfer of its stock interest in doing business as Salvatore Scallopini. Birmingham Ventures, Inc holds the Class C and SDM License with Sunday Sales (PM) and Outdoor Service Area located at 505 N Old Woodward, Birmingham, Oakland County, MI, and is requesting that stock owned by Eunice Bongiovanni Living Trust be transferred and divided among Kara Bongiovanni Living trust, Lawrence and Amy Bongiovanni Living Trust and Joseph Bongiovanni. The applicants, Amy Bongiovanni, Lawrence and Amy Bongiovanni, and Joseph Bongiovanni, have successfully completed the police background check. The current SLUP in place for Salvatore Scallopini is in the name of Birmingham Ventures, Inc. this will not change. The police department has not uncovered any information that would give cause to deny the applicant's request.

**SUGGESTED COMMISSION ACTION:**

Make a motion adopting a resolution to authorize the City Clerk to complete the Local Approval Notice at the request of Birmingham Ventures, Inc. to approve the request Eunice's Living Trusts to transfer the stock of Birmingham Ventures, Inc. which the stock is currently held by Eunice Bongiovanni, Living Trust Kara Bongiovanni Trustee, which holds the Class C and SDM License with Sunday Sales (PM) and Outdoor Service Area located at 505 N Old Woodward, Birmingham, Oakland County, MI to Kara Bongiovanni Living Trust, 170 shares, Lawrence and Amy Bongiovanni Living Trust 170 shares and Joseph Bongiovanni 170 shares.



## **MEMORANDUM**

Police Department

**DATE:** April 25, 2023  
**TO:** Thomas M. Markus, City Manager  
**FROM:** Scott A. Grewe, Chief of Police  
**SUBJECT:** Youth Academy Intergovernmental Agreement

---

### **INTRODUCTION:**

The Birmingham Police Department has decided to collaborate with police departments from Auburn Hills, the City of Rochester, and Bloomfield Township to establish a joint youth academy. The goal of the police youth academy is to allow students to experience hands-on activities and presentations for those interested in the field of law enforcement. Participating in community outreach programs, especially with our youth, is an important part of our community policing efforts.

### **BACKGROUND:**

Residents of the four jurisdictions or students who attend schools in our cities are able to apply if they are ages 14 to 18 years old. There is an application process that includes a very brief background check in order to be accepted into this program. Students will learn about many aspects of law enforcement including police tactics, investigations, criminal law and procedure, basic first aid and CPR certification, firearms safety and scenario-based training. This year's academy will take place from June 26-June 30, 2023.

It is the goal of all four agencies that this youth academy is an annual program. Training locations each year may change based on program needs and availability but will always be held at one of the four participating agencies.

### **LEGAL REVIEW:**

The attached agreement was written by our City Attorney and reviewed and approved by all four agencies participating in this joint youth academy.

### **FISCAL IMPACT:**

The academy is free of charge to participants and the cost associated with facilitating the academy will be split equally among the four participating agencies. It is estimated, each agency will be responsible for approximately \$1,000.00 to fund the academy class annually.

These funds will be taken from the police department's Operating Supply Fund – 101.0-301.000-729.0000.

**PUBLIC COMMUNICATIONS:**

This academy will be advertised by all four participating agencies to promote the program. It was also included in the manager's report at the April 24, 2023, City Commission meeting.

**SUMMARY:**

The Birmingham Police Department is joining with Auburn Hills Police, Rochester Police and Bloomfield Township Police to establish a regional youth academy. This academy will be open to all residents and students of schools located in any one of the four municipalities. Students will learn about many aspects of law enforcement including police tactics, investigations, criminal law and procedure, basic first aid and CPR certification, firearms safety and scenario-based training. This year's academy will take place from June 26-June 30, 2023.

**ATTACHMENTS:**

1. Intergovernmental Agreement for a Youth Academy Program
2. Promotional Flyer Advertising Program

**SUGGESTED COMMISSION ACTION:**

Make a motion adopting a resolution to approve the Intergovernmental Agreement between the City of Birmingham, the City of Auburn Hills, Bloomfield Township and the City of Rochester to establish a regional youth academy for residents and students of the four communities. Furthermore, to authorize the Chief of Police to sign the agreement on behalf of the City of Birmingham and the Birmingham Police Department.

**INTERGOVERNMENTAL AGREEMENT  
REGARDING YOUTH ACADEMY PROGRAM  
BETWEEN THE CITY OF BIRMINGHAM, CITY OF AUBURN HILLS,  
BLOOMFIELD TOWNSHIP AND THE ROCHESTER POLICE DEPARTMENT**

**THIS AGREEMENT** made and entered into this \_\_\_\_ day of \_\_\_\_\_, 2023, by and between the **CITY OF BIRMINGHAM**, whose municipal offices are located at 151 Martin Street, Birmingham, Michigan, 48012, **CITY OF AUBURN HILLS** whose municipal offices are located at 1827 N. Squirrel Road, Auburn Hills, Michigan, 48326, **BLOOMFIELD TOWNSHIP** whose municipal offices are located at 4200 Telegraph Road, P.O. Box 489, Bloomfield Township, MI, 48303 and the **ROCHESTER POLICE DEPARTMENT** whose municipal offices are located at 400 Sixth Street, Rochester, Michigan, 48307.

**WITNESSETH:**

The Intergovernmental Contract Act MCLA 123.1 et seq., provides that a municipal corporation shall have power to join with any other municipal corporation, by contract, or otherwise as may be permitted by law for the operation of performance, jointly, or by anyone or more, on behalf of any and all, of any service which would have the power to provide; and,

**WHEREAS**, the four police departments would like to provide for a Regional Youth Academy; and,

**WHEREAS**, the Academy will be five days in length and will be held at one central location hosted by one of the participating four police departments; and,

**WHEREAS**, there may be one day where participants will be dropped off and picked up at another location depending upon the training necessity; and,

**WHEREAS**, the Regional Youth Academy will take place during a week in the summer from 9:00 a.m. to 3:30 p.m. at the Bloomfield Township Police Department with a travel day to Rochester Police Department Training Facility; and,

**WHEREAS**, while transportation will not be provided by the four participating police departments, the Academy participants may walk to other facilities for training. for example, the 48<sup>th</sup> District Court for a courthouse tour from Bloomfield Township; and,

**WHEREAS**, the Academy is free of charge to participants and the cost associated with facilitating the Academy will be split equally among the four participating police departments. The cost may include training location, training equipment, uniform

requirements such as an Academy t-shirt and lunch to be provided daily to the participants; and,

**WHEREAS**, all four police departments participating in the Academy will be required to have at least one member from their department present during the Academy dates and hours. It is, however, possible that more training staff may be necessary depending upon the training activities scheduled that day; and,

**WHEREAS**, a meeting will be held for parents and guardians of the minors prior to the Academy taking place; and,

**WHEREAS**, the Youth Academy participants will fill out an application providing emergency information, and a Release and Indemnification Agreement for the participants in ride along programs and the Youth Academy, a Non-Disclosure and Confidentiality Agreement, and notification of the misuse of the statewide lien network (Attachments A through E).

**NOW, THEREFORE**, in consideration of the mutual undertakings of the parties hereto as herein set forth as agreed to by and between the parties as follows:

1. That the four police departments shall share the cost of the youth training in four equal parts. The amount is to be determined.
2. The term of this Agreement shall be for the planning and implementation of the Regional Youth Academy with anticipated completion by August 31 of each year. The terms of this Agreement may be continued on a yearly basis for a term of 10 years. Any party to this Agreement may terminate this Agreement for any reason or no reason, by giving sixty (60) days written notice to the other parties to this Agreement.
3. This Agreement shall be governed, performed and enforced in accordance with the laws of the State of Michigan, and in full compliance with all local, state and federal laws and regulations.
4. If any provision of this Agreement is declared invalid, illegal or unenforceable such provision shall be severed from this Agreement and all of the provisions shall remain in full force and effect.
5. Except as otherwise provided herein to the fullest extent permitted by law, each party shall be responsible for the acts and/or omissions of its own employees, officers and/or agents, the costs associated with those acts and/or omissions and for their own defense of those acts and/or omissions.
6. Each party agrees that it shall be responsible for any and all claims, costs, actions, causes of actions, losses or expenses including attorney's fees resulting from or



caused by its acts or omissions and the acts or omissions of its employees pursuant to this Agreement. Neither party shall construe the other as an employee.

7. If any breach is caused by any of the four police departments, written notice shall be given by the party believing a breach has occurred by regular mail and representatives and all four police departments will meet within seven days of receipt of notice to attempt to cure the alleged breach in question.

8. The four police departments have long shared a history of cooperation and each party pledges its best efforts to provide the same herein.

9. This Agreement may be modified only by the written agreement of all four police departments.

10. The four police departments have taken all actions and have secured all approvals necessary to authorize and complete this Agreement. The person signing this Agreement on behalf of each party shall have legal authority to sign this Agreement and bind the parties to the terms and conditions herein.

11. Notices shall be given to:

A. Auburn Hills Police Department  
1899 N. Squirrel Road  
Auburn Hills, MI 48326

Attention: Ryan Gagnon, Police Chief

With copy to: Attorney Derk Beckerleg

B. Birmingham Police Department  
151 Martin Street  
Birmingham, MI 48012

Attention: Scott Grewe, Police Chief

With copy to: Attorney Mary M. Kucharek

C. Bloomfield Township Police Department  
4200 Telegraph Road  
P.O. Box 489  
Bloomfield Township, MI 48303

Attention: James Gallagher, Police Chief

With copy to: Attorney Derk Beckerleg

D. Rochester Police Department  
400 Sixth Street  
Rochester, MI 48307

Attention: Steven Schettenhelm, Police Chief

With copy to: Attorney Jeffrey S. Kragt

CITY OF BIRMINGHAM	CITY OF AUBURN HILLS
By: _____	By: _____
Its: _____	Its: _____
Dated: _____	Dated: _____
BLOOMFIELD TOWNSHIP	CITY OF ROCHESTER
By: _____	By: _____
Its: _____	Its: _____
Dated: _____	Dated: _____

ATTACHMENT A

# REGIONAL YOUTH POLICE ACADEMY

## YOUTH POLICE ACADEMY | APPLICATION

*AUBURN HILLS POLICE, ROCHESTER POLICE  
BLOOMFIELD TOWNSHIP POLICE, BIRMINGHAM POLICE*



APPLICANT'S NAME: \_\_\_\_\_  
LAST FIRST MIDDLE

APPLICATIONS DUE: **THURSDAY, JUNE 5TH, 2023**

## **REGIONAL YOUTH POLICE ACADEMY**

YOUTH POLICE ACADEMY | APPLICATION

# YOUTH POLICE ACADEMY INFORMATION

### WHO CAN PARTICIPATE?

- ANY CURRENT HIGH SCHOOL STUDENT (CAN BE ENTERING YOUR JUNIOR OR SENIOR YEAR, ALSO APPLIES TO SENIORS WHO JUST GRADUATED) AGE 14-18 WHO LIVES IN OR ATTENDS HIGH SCHOOL IN OAKLAND COUNTY **OR** HAS A PARENT WHO LIVES, WORKS OR GOES TO SCHOOL IN AUBURN HILLS, BLOOMFIELD TOWNSHIP, BIRMINGHAM, OR CITY OF ROCHESTER.
- MUST POSSESS GOOD MORAL CHARACTER, A GOOD WORK ETHIC AND DEMONSTRATE THEIR HONESTY AND TRUSTWORTHINESS.
- BE IN GOOD LEGAL STANDING WITH AN ACCEPTABLE LEGAL HISTORY
- BE IN GOOD PHYSICAL CONDITION AND PROVIDE PROOF OF A PHYSICAL BY A LICENSED PHYSICIAN WITHIN 12 MONTHS OF THE ACADEMY
- AUTHORIZE THE AUBURN HILLS POLICE DEPARTMENT AND ITS AGENTS TO UTILIZE THE LEIN/NCIC SYSTEM TO CONDUCT A THOROUGH BACKGROUND CHECK

### ACADEMY DATE & MANDATORY INFORMATIONAL MEETING:

- **JUNE 26<sup>TH</sup> – JUNE 30<sup>TH</sup> | 9:00AM-3:30PM** (ALL ACADEMY DAYS ARE MANDATORY)
- GRADUATION TO TAKE PLACE AT THE BLOOMFIELD TOWNSHIP CITY COMPLEX ON FRIDAY JUNE 30<sup>TH</sup>.
- **MANDATORY INFORMATIONAL MEETING: WEDNESDAY, JUNE 7<sup>TH</sup> @ 7:00PM**
  - MEETING WILL TAKE PLACE IN THE BLOOMFIELD TOWNSHIP TRAINING CENTER (4315 ANDOVER RD., BLOOMFIELD HILLS).
    - ATLEAST ONE PARENT MUST BE IN ATTENDANCE
    - BRING A COPY OF HEALTH INSURANCE INFORMATION/BE ABLE TO PROVIDE MEDICAL HISTORY OF THE STUDENT

### SUBMIT COPIES OF THE FOLLOWING WITH YOUR APPLICATION:

- DRIVER'S LICENSE/STATE IDENTIFICATION CARD (IF APPLICABLE)
- STUDENT IDENTIFICATION CARD
- PROOF OF PHYSICAL WITHIN 12 MONTHS OF THE ACADEMY DATE
- ALL COMPLETED APPLICATION MATERIALS

## **REGIONAL YOUTH POLICE ACADEMY**

YOUTH POLICE ACADEMY | APPLICATION

### **WHAT WILL BE PROVIDED:**

- UNIFORM PIECES (ACADEMY T-SHIRT/POLO)
- ALL MATERIALS INCLUDING BOOKS AND CLASSROOM SUPPLIES
- LUNCH DURING EACH DAY OF THE ACADEMY

### **WHAT YOU WILL NEED TO PROVIDE:**

- BUSINESS CASUAL PANTS (KHAKI, ETC)
- APPROPRIATE WORKOUT/ATHLETIC ATTIRE
  - ATHLETIC SHORTS / PANTS
  - GOOD RUNNING/ATHLETIC SHOES WITH SUPPORT
- DUFFLE BAG OR BACKPACK TO CARRY MATERIALS
- TRANSPORTATION TO AND FROM THE BLOOMFIELD TOWNSHIP TRAINING CENTER (4315 ANDOVER RD., BLOOMFIELD HILLS) BEFORE AND AFTER THE ACADEMY
- ON THURSDAY, 6/29/23, TRANSPORTATION WILL BE NEEDED TO AND FROM THE ROCHESTER CITY FIRE DEPARTMENT (277 E. 2<sup>ND</sup> STREET, ROCHESTER, MI)
- SUNSCREEN, BUG SPRAY (IF YOU FEEL NECESSARY) AND ANY MEDICATIONS YOU WILL NEED TO TAKE DURING THE ACADEMY

### **CONTACT INFORMATION**

ALL QUESTIONS OR CONCERNS SHOULD BE DIRECTED TO:

***OFFICER NICK SOLEY***

4200 TELEGRAPH RD.

BLOOMFIELD TOWNSHIP, MI 48303

(248) 433-7724

[CRO@BLOOMFIELDTWP.ORG](mailto:CRO@BLOOMFIELDTWP.ORG)

**REGIONAL YOUTH POLICE ACADEMY**  
YOUTH POLICE ACADEMY | APPLICATION

**APPLICATION INSTRUCTIONS**

- READ EVERY QUESTION CAREFULLY AND ANSWER ALL QUESTIONS ON THE APPLICATION
- IF THE QUESTION DOESN'T APPLY TO YOU, FILL IN N.A. DO NOT LEAVE ANY PART OF THE APPLICATION BLANK
- YOUR APPLICATION SHALL BE PRINTED CLEARLY IN YOUR OWN HANDWRITING OR FILL IN THE APPLICATION VIA THE COMPUTER AND TYPE ANSWERS INTO THE BLANKS
- ANSWER EVERY QUESTION COMPLETELY AND TRUTHFULLY, IF THERE IS INSUFFICIENT SPACE TO ANSWER, INCLUDE AN ADDITIONAL SHEET OF PAPER WITH THE QUESTION NUMBER AND ANSWER

**SEND ALL COMPLETED MATERIALS**  
**BY MONDAY JUNE 5TH, 2023**

VIA EMAIL: [CRO@BLOOMFIELDTWP.ORG](mailto:CRO@BLOOMFIELDTWP.ORG)

OR

MAIL OR DELIVER IN PERSON:

OFC. SOLEY  
BLOOMFIELD TOWNSHIP POLICE DEPARTMENT  
4200 TELEGRAPH RD.  
BLOOMFIELD TOWNSHIP, MI 48303  
(248) 433-7724

# REGIONAL YOUTH POLICE ACADEMY

## YOUTH POLICE ACADEMY | APPLICATION

APPLICANT INFORMATION											
Last Name				First				M.I.	DOB:		
Street Address							Apartment/Unit #				
City				State				ZIP			
Phone				E-mail Address							
Parent/Guardian Name				Parent/Guardian Phone				Parent/Guardian Email			
Do you live, work or attend a school in the City of Auburn Hills, Bloomfield Township, Birmingham or Rochester? If so, provide the name and address of the establishment/institution.											
Have you attended OUR academy before?				YES <input type="checkbox"/>	NO <input type="checkbox"/>	Are you available from June 20 <sup>th</sup> -24 <sup>th</sup> ?			YES <input type="checkbox"/>	NO <input type="checkbox"/>	
Have you ever been arrested?				YES <input type="checkbox"/>	NO <input type="checkbox"/>	If so, when?					
Have you ever been convicted of a misdemeanor or felony?				YES <input type="checkbox"/>	NO <input type="checkbox"/>	If yes, explain					
EDUCATION (IF THERE IS NOT ENOUGH SPACE FOR AWARDS, INCLUDE ADDITIONAL SHEET/LIST)											
Jr. High (6-8)					CITY						
From	To	Did you graduate?		YES <input type="checkbox"/>	NO <input type="checkbox"/>	Awards					
High School					Address						
From	To	Did you graduate?		YES <input type="checkbox"/>	NO <input type="checkbox"/>	Awards					
College/Tech School					Address						
From	To	Did you graduate?		YES <input type="checkbox"/>	NO <input type="checkbox"/>	Awards					
Were you ever expelled or suspended from High School or Jr. High? If so explain: when, where and reason on the back of this page.											
REFERENCES											
<i>Please list One Personal Reference (Family Member, Friend) and Two Professional References (Boss, Coach, Teacher).</i>											
Full Name				Relationship							
Company				Phone							
Address											
Full Name				Relationship							
Company				Phone							
Address											
Full Name				Relationship							
Company				Phone							
Address											



# REGIONAL YOUTH POLICE ACADEMY

YOUTH POLICE ACADEMY | APPLICATION

VOLUNTEER/EXTRA-CURRICULAR ACTIVITY	
List extra-curricular activity	Total Hours per Week
List Volunteer activity/organizations	Does this conflict with the academy?

DISCLAIMER AND SIGNATURE	
I certify that my answers are true and complete to the best of my knowledge. I understand that false or misleading information in my application or Interview will result in my release. Furthermore I acknowledge that the Auburn Hills Police Department reserves the right to suspend or terminate the participation of any participant who engages in unsafe, insubordinate, or illegal behavior at any time before or during the Youth Police Academy. Finally, my submission of this application permits the Auburn Hills Police Department and its agents to perform a background check utilizing the LEIN/NCIC, Secretary of State and CLEMIS systems.	
Signature	Date

ATTACHMENT B

# REGIONAL YOUTH ACADEMY EMERGENCY INFORMATION

Emergency Information, Participants

Participant Full Name \_\_\_\_\_

Address \_\_\_\_\_  
\_\_\_\_\_

Home Phone \_\_\_\_\_

Cell Phone \_\_\_\_\_

Work Phone \_\_\_\_\_

Email Address \_\_\_\_\_

Date of Birth \_\_\_\_\_

Driver License Number \_\_\_\_\_

Affiliation/ School \_\_\_\_\_  
(Reason for participation)

## EMERGENCY INFORMATION:

In case of emergency, please contact:

	Name	Phone Number	Address	Relationship
1				
2				
3				

Known medical concerns of participant: \_\_\_\_\_  
\_\_\_\_\_  
\_\_\_\_\_

Those who choose to participate in an optional simulated MCOLES physical agility test must affirm they are physically and medically capable to do so. Participation in this event is not required. The MCOLES physical fitness test consists of four separate events: vertical jump, sit-ups, push-ups, and a half mile shuttle run. By signing below, the parent or guardian affirms the participant is capable of performing one or more of these tasks and has obtained a clear physical within the last 6 months.

Parent/Guardian Signature: \_\_\_\_\_ Date: \_\_\_\_\_

Parent/Guardian Printed Name: \_\_\_\_\_

Youth Police Academy

ATTACHMENT C

# REGIONAL YOUTH ACADEMY RELEASE AND INDEMNIFICATION AGREEMENT

## Ride-Along Program / Youth Academy

That, \_\_\_\_\_ (hereinafter "Releasor"), for and in consideration of the permission granted to Releasor by the City of Auburn Hills, City of Birmingham, Township of Bloomfield and City of Rochester, Michigan, Michigan municipal corporations participating in the Regional Youth Academy (hereinafter "Releasee"), to accompany an officer or officers of represented in the Regional Youth Academy on patrol in a police vehicle, (hereinafter "Ride-Along Program"), and / or to participate in the Youth Police Academy (hereinafter "Regional Youth Academy") does hereby remise, release and forever discharge the Releasee, its agents, officers, representatives, servants or employees, of and from all debts, obligations, reckonings, promises, covenants, agreements, contracts, endorsements, bonds, specialties, controversies, suits, actions, cause of action, trespasses, variances, judgment, extents, torts, executions, damages, liabilities, property damages, bodily injuries, including death, claims, or demands, in law or in equity, the Releasor ever had, now has or hereafter shall, or may have against Releasee, its agents, officers, representatives, servants or employees, for, upon or by reason of any matter, cause or thing whatsoever, arising out of Releasor's participation in the Ride-Along Program and / or Regional Youth Academy.

More particularly, and not by way of limitation of the foregoing, the Releasor hereby waives all claims for damages occasioned by injury or to loss of person or property, including death, which may be caused by any act or failure to act by the Releasee, its agents, officers, representatives, servants or employees, whether negligent or otherwise. The Releasor hereby assumes the risk of all dangerous conditions or occurrences which may be encountered during said Ride-Along Program and Regional Youth Academy and waives any and all specific notice of the existence of such conditions or occurrences. Specifically, and still not by way of limitation of the foregoing waiver, the Releasor acknowledges that it is the policy of the Regional Youth Academy to cause a rider in the Ride-Along Program to exit a patrol vehicle, if possible, in the event of a call involving extraordinary danger, but waives any claims for damages aforesaid in the event, or any reason, the Releasor continues to accompany an officer, notwithstanding such policy. It is further recognized that involvement in the Youth Academy may subject and expose Releasor to hazardous conditions and activities, including (but not limited to) use and observation of firearms, "simunition" programs, use and exposure of certain chemical agents, physical demonstrations of force, and various police demonstrations. That these programs are voluntary, and that Releasor has chosen to participate with full knowledge and acceptance of all known, unforeseen, and unforeseeable risks.

The Releasor agrees to indemnify and save the Releasee, its agents, officers, representatives, servants and employees, harmless from any demand, claim, liability or judgment, including attorney's fees and costs, which may be occasioned by an act or omission on the part of the Releasor or Releasee or its agents, officers, representatives, servants or employees during the activity described herein.

The Releasor agrees the permission to participate in the Ride-Along Program and Regional Youth Academy is revocable at will by the Releasee.

The Releasor has read the above and agrees to same. The Releasor represents that he/she is over the age of 18 years, or is authorized to participate pursuant to the above waiver by a parent or legal guardian.

\_\_\_\_\_  
RELEASOR

ATTACHMENT D

# REGIONAL YOUTH ACADEMY NON-DISCLOSURE, CONFIDENTIALITY AGREEMENT

## Youth Academy Participants

During the course of visitation/ride-along with the Regional Youth Academy you may be exposed to confidential criminal records and/or Michigan Secretary of State Records information. The confidentiality of this information is controlled by statute. The misuse of such information may adversely affect an individual's civil rights and violates the law.

Misuse of the Michigan State Police Law Enforcement Information Network (LEIN) and its interfaced systems violates Michigan Compiled Law 28.214, Section 4 of the C.J.I.S. Policy Council Act. Misuse of the FBI National Crime Information Center (NCIC) is subject to additional federal criminal and/or civil penalties. Misuse of the criminal history record information obtained through NCIC violates the Code of Federal Regulation, Title 28, Section 20.25. Misuse of Secretary of State (SOS) records violates State of Michigan driver and vehicle privacy protections laws [MCL 28.295a, 257.902, 257.903, 324.80130d, 324.80319a, 324.81120, 324.82160, and other provisions of law]. Misuse of motor vehicle records is subject to additional federal criminal and/or civil penalties.

Violation of this law, by you, as an observer of the procedures of the Regional Youth Academy participating agencies, may result in your being prosecuted in a criminal and/or civil action.

Participants may be exposed to privileged and confidential information and must agree not to discuss such information with anyone.

Participants shall respect and preserve the confidentiality of all names of persons and information learned through the visit/ride-along, unless otherwise authorized.

Participants shall not use department equipment, including computers, cameras, and recording equipment except when directly authorized by department staff or in extreme emergencies.

Under the requirements of the federal Health Insurance Portability and Accountability Act (HIPAA), visitors/ride-along participants who may come into contact with private health related information will agree in writing, to keep all confidential information learned during their visit/ride-along participation confidential.

Whereas in connection with the undersigned's participation in the Regional Youth Academy Visitation/Ride-Along Program, the undersigned may become privy to certain information that should not be disclosed to other individuals and which may include data which is classified as private, confidential or non-public under State and Federal law;

NOW, THEREFORE, in consideration of the promises and other good and valuable consideration, the sufficiency of which is hereby acknowledged, the undersigned does hereby:

Agree to refrain from disclosing to a spouse, parent, child, friend or any other individual information of any nature that the undersigned may obtain through his/her participation in the Regional Youth Academy Visitation/Ride-Along Program.

\_\_\_\_\_  
Signature

\_\_\_\_\_  
Date

\_\_\_\_\_  
Witness

\_\_\_\_\_  
Date

*\*Provide with copy of Notification of Criminal Penalties and Civil Action for the Misuse of LEIN*

Youth Police Academy

ATTACHMENT E



# REGIONAL YOUTH ACADEMY MISUSE OF LEIN NOTIFICATION

## Youth Academy Participants

Misuse of the Michigan State Police Law Enforcement Information Network (LEIN) and its interfaced systems violates Michigan Compiled Law 28.214, Section 4 of the C.J.I.S. Policy Council Act:

- (3) A person shall not access, use, or disclose nonpublic information governed under this act for personal use or gain.
- (5) A person shall not disclose information governed under this act in a manner that is not authorized by law or rule.
- (6) A person who intentionally violates subsection (3) or (5) is guilty of a crime as follows:
  - (a) For a first offense, the person is guilty of a misdemeanor punishable by imprisonment for not more than 93 days or a fine of not more than \$500.00, or both.
  - (b) For a second or subsequent offense, the person is guilty of a felony punishable by imprisonment for not more than 4 years or a fine of not more than \$2,000.00, or both.

Misuse of the FBI National Crime Information Center (NCIC) is subject to additional federal criminal and/or civil penalties. The federal Privacy Act of 1974 states:

- (3) Any person who knowingly and willfully requests or obtains any record concerning an individual from an agency under false pretenses shall be guilty of a misdemeanor and fined not more than \$5,000. [5 USC Sec.552a(i)]

Misuse of criminal history record information obtained through NCIC violates the Code of Federal Regulation, Title 28, Section 20.25:

Any agency or individual violating subpart B [State and Local Criminal History Record Information] of these regulations shall be subject to a civil penalty not to exceed \$11,000 for a violation occurring on after September 29, 1999.

Misuse of Secretary of State (SOS) records violates State of Michigan driver and vehicle privacy protections laws. [MCL 28.295a, 257.902, 257.903, 324.80130d, 324.80319a, 324.81120, 324.82160, and other provisions of law.]

Under Michigan law, a person who makes a false representation or a false certification to obtain personal information or who uses personal information for a purpose other than a permissible purpose identified in the law is guilty of a felony, which may be punishable by imprisonment for up to 5 years and/or a fine of up to \$5,000. Subsequent convictions may result in imprisonment for up to 15 years and/or a fine of up to \$15,000.

Misuse of motor vehicle records is subject to additional federal criminal and/or civil penalties. The federal Driver's Privacy and Protection Act of 1994 states:

18 USC Sec. 2723:

- (a) Criminal Fine. – A person who knowingly violates this chapter shall be fined under this title.

18 USC Sec. 2724:

- (a) Cause of Action. – A person who knowingly obtains, discloses or uses personal information, from a motor vehicle record, for a purpose not permitted under this chapter shall be liable to the individual to whom the information pertains, who may bring a civil action in a United States district court.
- (b) Remedies. – The court may award –
  - (1) actual damages, but not less than liquidated damages in the amount of \$2,500;
  - (2) punitive damages upon proof of willful or reckless disregard of the law;

I have read and understand the above Notice of Criminal Penalties and Civil Action and I agree to comply with its contents. Further, I understand that any violation of its contents may result in disciplinary action and/or referral for prosecution.

\_\_\_\_\_  
Signature

\_\_\_\_\_  
Date

\_\_\_\_\_  
Printed Name

Youth Police Academy



**JUNE 26-30**  
**9:00 AM - 3:30 PM**

**Bloomfield Township Training Center**  
 4315 Andover Road  
 Bloomfield Hills, MI 48302

**Get an in-depth look into the world of policing!**

Students ages 14-18 years old will get to experience many aspects of law enforcement, including a hands-on look at police equipment, tactics, investigations, criminal law and procedure, basic first aid, CPR certification, firearms safety, and scenario based training.



No cost to participate! Uniform T-shirts and lunch will be provided to attendees.

Email [CRO@bloomfieldtwp.org](mailto:CRO@bloomfieldtwp.org) for an application.

Space is limited. You will be notified if accepted to the program.

**Who can participate?** Any current high school student (also applies to seniors who just graduated) age 14-18 who lives in or attends high school in Auburn Hills, Rochester, Bloomfield Township, or Birmingham or has a parent who lives, works or goes to school in Auburn Hills, Rochester, Bloomfield Township, or Birmingham | Must possess good moral character, a good work ethic and demonstrate their honesty and trustworthiness | Be in good legal standing with an acceptable legal history | Authorize the respective participating Police Departments and its agents to utilize the LEIN/NCIC system to conduct a thorough background check



## **MEMORANDUM**

(Police Department)

**DATE:** April 25, 2023

**TO:** Thomas M. Markus, City Manager

**FROM:** Chris Koch, Investigative Captain

**APPROVED:** Scott A. Grewe, Chief of Police

**SUBJECT:** PROGRAM YEAR 2023 HIGH INTENSITY DRUG TRAFFICKING AREA (HIDTA) SUBRECIPIENT AGREEMENT BETWEEN THE COUNTY OF OAKLAND AND CITY OF BIRMINGHAM Data Universal Numbering System (DUNS) #: 074239450

---

---

### INTRODUCTION:

The police department is a member of the Oakland County Sheriff's Office Narcotic Enforcement Team (NET) by an approved inter-local agreement between the City and Oakland County. In addition to Birmingham, thirteen other communities are also members of NET by the inter-local agreement.

### BACKGROUND:

In 2023, with the permission and cooperation of all thirteen member agencies, the Oakland County Sheriff's Office applied for a grant through the Executive Board for Michigan High Intensity Drug Trafficking Area (HIDTA) requesting the United States Office of Drug Control Policy (ONDCP) grant NET an award of \$132,300.00 for the program year 2023 (January 1, to December 31, 2023). The grant award will allow partial funding for overtime reimbursement of NET investigators for drug investigations. Oakland County will reimburse the City up to \$5,700.00 for qualifying NET related overtime.

### LEGAL REVIEW:

Legal Counsel reviewed the inter-local agreement and no issues were found to exist.

### FISCAL IMPACT:

If approved, the City would receive grant funding reimbursement from Oakland County up to \$5,700.00 for qualifying NET related overtime.

**PUBLIC COMMUNICATIONS:**

None

**SUMMARY:**

In order to receive funds from the grant, the City of Birmingham is required to enter into a sub recipient agreement with Oakland County. The purpose of the agreement is to delineate the relationship and responsibilities regarding the County's use of grant funds to reimburse municipalities for overtime incurred as it relates to participation in the Oakland County Narcotic Enforcement Team (NET).

**ATTACHMENTS:**

1. Program Year 2023 High Intensity Drug Trafficking Area (HIDTA) sub recipient agreement between the County of Oakland and the City of Birmingham.

**SUGGESTED COMMISSION ACTION:**

Make a motion adopting a resolution to approve the Program Year 2023 High Intensity Drug Trafficking Area (HIDTA) sub recipient agreement between the County of Oakland and the City of Birmingham. Further, to authorize the Mayor to sign the agreement on behalf of the City.

**PROGRAM YEAR 2023  
HIGH INTENSITY DRUG TRAFFICKING AREA (HIDTA)  
SUBRECIPIENT AGREEMENT BETWEEN  
THE COUNTY OF OAKLAND AND CITY OF BIRMINGHAM  
Data Universal Numbering System (DUNS) #: 074239450**

---

This Agreement is made between Oakland County, a Constitutional Corporation, 1200 North Telegraph, Pontiac, Michigan 48341 ("County") and City of Birmingham, 151 Martin St., Birmingham, MI 48009, a Michigan Municipal Corporation ("Municipality"). The County and Municipality shall be collectively referred to as the "Parties."

**PURPOSE OF AGREEMENT.**

The Parties enter into this Agreement for the purpose of delineating their relationship and responsibilities regarding the County's use of Grant funds (defined below) to reimburse the Municipality for overtime expenses that it incurred related to its participation in the Oakland County Narcotic Enforcement Team ("N.E.T."), a multijurisdictional drug enforcement task force under the direction and supervision of the Oakland County Sheriff's Office ("OCSO").

Under the Parties' separate N.E.T. agreement, the Municipality is responsible for providing a full-time employee for participation in N.E.T. and for all costs associated with that employment, including overtime.

The County, as the legal entity that administers N.E.T., submitted an Initiative Description and Budget Proposal (Exhibit A) to the Executive Board for Michigan HIDTA requesting the United States Office of National Drug Control Policy ("ONDCP") to grant N.E.T. an award for program year (PY) 2023 to reimburse N.E.T. participating agencies for eligible law enforcement officer overtime. PY 2023 begins January 1, 2023 and ends December 31, 2023.

If ONDCP grants N.E.T. an award for PY 2023, the ONDCP disburses the HIDTA grant funds to the Michigan State Police ("MSP"). To receive the Grant funds for overtime costs, N.E.T. must submit requests for reimbursement with the required supporting documentation to Michigan HIDTA. If Michigan HIDTA approves the N.E.T. overtime reimbursement requests, the MSP should distribute the Grant funds to County on behalf of N.E.T. The County has the authority to allocate a portion of the Grant funds to reimburse the Municipality for qualifying overtime costs subject to the terms and conditions of this Agreement.

In consideration of the mutual promises, obligations, representations, and assurances in this Agreement, the Parties agree to the following:

- DEFINITIONS.** The following terms, whether used in the singular or plural, within or without quotation marks, or possessive or nonpossessive, shall be defined, read, and interpreted as follows.

- 1.1. **Claim** means any alleged loss, claim, complaint, demand for relief or damages, cause of action, proceeding, judgment, deficiency, liability, penalty, fine, litigation, costs, and/or expenses, including, but not limited to, reimbursement for attorney fees, witness fees, court costs, investigation expenses, litigation expenses, and amounts paid in settlement, which are imposed on, incurred by, or asserted against the County or Municipality, or the County’s or Municipality’s agents or employees, whether such claim is brought in law or equity, tort, contract, or otherwise.
- 1.2. **Grant funds** mean the funds that may be awarded to the County and the other participating agencies in N.E.T. pursuant to Michigan HIDTA Initiative Description and Budget Proposal Version 2023 (Exhibit A) submitted to Michigan HIDTA by County on behalf of itself and the other participating agencies in N.E.T.

**2. EXHIBITS.** The Exhibits listed below are incorporated and are part of this Agreement.

- 2.1. **Exhibit A** – Michigan HIDTA Initiative Description and Budget Proposal Version 2023.
- 2.2. **Exhibit B** - Template Request for HIDTA Overtime Reimbursement (Locals to County).
- 2.3. **Exhibit C** – Sample letter regarding notification of current overtime pay rate.
- 2.4. **Exhibit D** – Sample overtime slip, signed by the officer’s supervisor that supports each Request for HIDTA Overtime Reimbursement.
- 2.5. **Exhibit E** – Sample paystub or payroll report that supports each Request for HIDTA Overtime Reimbursement.

**3. FEDERAL AWARD PROJECT DESCRIPTION.**

- 3.1. Catalog of Federal Domestic Assistance (“CFDA”) #: 95.001
- 3.2. Federal Awarding Agency: United States Office of National Drug Control Policy (“ONDCP”)
- 3.3. Program: High Intensity Drug Trafficking Areas (HIDTA)
  - 3.3.1. HIDTA Objective: To reduce drug trafficking and drug production in the United States by: (A) facilitating cooperation among Federal, State, local, and tribal law enforcement agencies to share information and implement coordinated enforcement activities; (B) enhancing law enforcement intelligence sharing among Federal, State, local, and tribal law enforcement agencies; (C) providing reliable law enforcement intelligence to law enforcement agencies needed to design effective enforcement strategies and operations; and (D) supporting coordinated law enforcement strategies which maximize use of available resources to reduce the supply of illegal drugs in designated areas and in the United States as a whole.
- 3.4. Period of Performance: January 1, 2023 through December 31, 2023.

2023 HIGH INTENSITY DRUG TRAFFICKING AREA (HIDTA) GRANT  
 SUBRECIPIENT AGREEMENT BETWEEN  
 OAKLAND COUNTY  
 AND  
 CITY OF BIRMINGHAM

3.5. The Federal Award Identification Number (FAIN) is provided in the HIDTA Grant Agreement between ONDCP and MSP, which is incorporated into this Agreement by reference.

#### **4. USE OF HIDTA FUNDS.**

4.1. The total amount of the federal award for overtime costs committed to the Municipality and obligated by this action by the County to the Municipality is not to exceed **\$5,700.00** for each participating law enforcement officer unless otherwise provided herein. That amount is based on the number of N.E.T participating agencies and eligible law enforcement officers at the time this Agreement was executed by both Parties. If the number of N.E.T participating agencies and/or eligible law enforcement officers changes during the term of this Agreement, the total amount of the federal award for overtime costs committed to the Municipality and obligated by this action by the County to the Municipality amount may change as funds are available on a pro rata basis. Such commitment and obligation for overtime costs is contingent upon the ONDCP awarding the Grant funds to N.E.T and the MSP reimbursing the County.

4.2. The County will reimburse the Municipality up to **\$5,700.00** for each participating law enforcement officer for qualifying N.E.T.-related overtime unless otherwise provided herein. That amount is based on the number of N.E.T participating agencies and eligible law enforcement officers at the time this Agreement was executed by both Parties. If the number of N.E.T participating agencies and/or eligible law enforcement officers changes during the term of this Agreement, the maximum reimbursement amount may change as funds are available on a pro rata basis. Such reimbursement shall only be made after the supporting documentation is submitted by the Municipality and approved by the County, as described in Paragraph 5.1. Such reimbursement is contingent upon the ONDCP awarding the grant funds to N.E.T and the MSP reimbursing the County.

4.2.1. HIDTA funds shall be used to pay overtime only if the overtime was performed in support of a HIDTA-designated Enforcement initiative or Intelligence and information Sharing Initiative. HIDTA funds shall not be used to pay overtime related to training attendance, financial management, drug treatment, drug demand reduction or prevention, or non-investigative related administrative work.

4.2.2. No HIDTA funds shall be used to supplant the Municipality's funds that would otherwise be made available for the same purposes.

4.3. There is no research and development performed pursuant to this Agreement.

4.4. No indirect costs shall be charged or reimbursed under performance of this Agreement.

#### **5. REIMBURSEMENT OF ELIGIBLE NET OVERTIME.**

5.1. To request reimbursement for eligible N.E.T. overtime costs, the Municipality shall submit to the County the documentation described in the following subparagraphs no later than thirty (30) days after PY 2023 has expired. If the County, in its sole discretion, determines that the

documentation submitted by the Municipality does not reconcile, then the Municipality shall provide any additional documentation requested by the County in order to process payment.

- 5.1.1. A fully completed and signed Request for HIDTA Overtime Reimbursement attached as Exhibit B.
  - 5.1.2. A letter substantively similar to the sample letter regarding notification of current overtime pay rate attached as Exhibit C.
  - 5.1.3. Overtime slips, signed by the officer’s supervisor, that support each Request for HIDTA Overtime Reimbursement. The overtime slips shall be substantively similar to the sample overtime slip attached as Exhibit D.
  - 5.1.4. The paystub or payroll report that supports each Request for HIDTA Overtime Reimbursement. The paystub or payroll report shall be substantively similar to the sample paystub attached as Exhibit E.
- 5.2. County will only reimburse Municipality for approved overtime costs after County has received the Grant funds from MSP for that particular reimbursement request.

**6. GENERAL COMPLIANCE.**

- 6.1. The Municipality shall comply with to 28 C.F.R. Part 69 (New Restrictions on Lobbying) and 2 C.F.R. Part 25 (Universal Identifier and System of Award Management).
- 6.2. The Municipality shall comply with the Government-wide Suspension and Debarment provision set forth at 2 CFR Part 180.
- 6.3. The Municipality shall perform all activities in accordance with The Uniform Administrative Requirements, Cost Principles, and Audit Requirements in 2 C.F.R. Part 200 (the “Part 200 Uniform Requirements”), as adopted and implemented by the Office of National Drug Control Policy (ONDCP) in 2 C.F.R. Part 3603. For this award, the Part 200 Uniform Requirements supersede, among other things, the provisions of 28 C.F.R. Parts 66 and 70, as well as those of 2 C.F.R. Parts 215, 220, 225, and 230.
- 6.4. The Municipality shall comply with ONDCP’s HIDTA Program Policy and Budget Guidance, all other applicable Federal, state, and local laws and regulations, and the terms and conditions contained in this Agreement.
- 6.5. The Municipality shall comply with all applicable requirements for subrecipients that are provided in the HIDTA Grant Agreement between ONDCP and MSP. The HIDTA Grant Agreement between ONDCP and MSP will be provided to the Municipality within a reasonable time after the County receives a copy of it.
- 6.6. As specified in the HIDTA Program Policy and Budget Guidance, the Municipality must:

2023 HIGH INTENSITY DRUG TRAFFICKING AREA (HIDTA) GRANT  
SUBRECIPIENT AGREEMENT BETWEEN  
OAKLAND COUNTY  
AND  
CITY OF BIRMINGHAM



- 6.6.1. Establish and maintain effective internal controls over the Federal award that provides reasonable assurance that Federal award funds are managed in compliance with Federal statutes, regulations and award terms and conditions. These internal controls should be in compliance with the guidance in “Standards for Internal Control in the Federal Government,” issued by the Comptroller General of the United States and the “Internal Control Integrated Framework,” issued by the Committee of Sponsoring Organizations of the Treadway Commission (COSO).
- 6.6.2. Comply with Federal statutes, regulations, and the terms and conditions of the Federal awards.
- 6.6.3. Evaluate and monitor compliance with applicable statute and regulations, and the terms and conditions of the Federal award.
- 6.6.4. Take prompt action when instances of noncompliance are identified, including noncompliance identified in audit findings.
- 6.6.5. Take reasonable measures to safeguard protected personally identified information (PII) and other information ONDCP or the Municipality designates consistent with applicable Federal, state, and local laws regarding privacy and obligations of confidentiality.

**7. FINANCIAL ACCOUNTABILITY AND AUDIT REQUIREMENTS.**

- 7.1. The Municipality shall maintain standards of financial accountability that conform to 2 C.F.R. §200.302 (Financial Management) and 2 C.F.R. §200.303 (Internal Controls).
- 7.2. The Municipality shall comply with audit requirements contained in 2 C.F.R. Part 200, Subpart F, which requires the Municipality to have an annual audit conducted within nine (9) months of the end of their fiscal year, if the Municipality has an aggregate expenditure of more than \$750,000 in federal funds in a fiscal year. Any deficiencies noted in audit reports must be fully cleared by the Municipality within thirty (30) days after receipt of same. The Grant funds spent by the County on behalf of the Municipality for training expenses shall be included on the Schedule of Expenditures of Federal Awards if the Municipality is required to have a single audit performed. Municipalities that are exempt from the Single Audit requirements that receive less than \$750,000 of total Federal funding must submit a Financial Statement Audit prepared in accordance with Generally Accepted Auditing Standards (“GAAS”) if the audit includes disclosures that may negatively impact the HIDTA program including, but not limited to fraud, financial misstatements, and violations of any contract or grant provisions. The County shall have the right to review and audit all records of the Municipality pertaining to any payment by the County.

**8. CONFLICT OF INTEREST.**

- 8.1. The Municipality shall comply with the following ONDCP conflict of interest policies:

- 8.1.1. As a non-Federal entity, you must maintain written standards of conduct covering conflicts of interest and governing the performance of your employees engaged in the selection, award, and administration of subawards and contracts.
- 8.1.2. None of your employees may participate in the selection, award, or administration of a subaward or contract supported by a Federal award if he or she has a real or apparent conflict of interest. Such a conflict of interest would arise when the employee, officer, or agent, any member of his or her immediate family, his or her partner, or an organization which employs or is about to employ any of the parties indicated herein, has a financial or other interest in or a tangible personal benefit from an organization considered for a subaward or contract. The officers, employees, and agents of the non-Federal entity must neither solicit nor accept gratuities, favors, or anything of monetary value from subrecipients or contractors or parties to subawards or contracts.
- 8.1.3. If you have a parent, affiliate, or subsidiary organization that is not a State, local government, or Indian tribe, you must also maintain written standards of conduct covering organizational conflicts of interest. Organizational conflicts of interest means that because of relationships with a parent company, affiliate, or subsidiary organization, you are unable or appear to be unable to be impartial in conducting a sub-award or procurement action involving a related organization.

## **9. MANDATORY DISCLOSURE.**

- 9.1. As a non-Federal entity, the Municipality must disclose, in a timely manner, in writing to ONDCP all violations of Federal criminal law involving fraud, bribery or gratuity violations potentially affecting the Federal award. Non-Federal entities that have received a Federal award that includes the term and condition outlined in 200 CFR Part 200, Appendix XII “Award Term and Condition for Recipient Integrity and Performance Matters,” are required to report certain civil, criminal, or administrative proceedings to System for Award Management (SAM). Failure to make required disclosures can result in remedies such as: temporary withholding of payments pending correction of the deficiency, disallowance of all or part of the costs associated with noncompliance, suspension, termination of award, debarment, or other legally available remedies outlined in 2 CFR 200.338 “Remedies for Noncompliance”.

## **10. RECORD RETENTION.**

- 10.1. The Municipality shall comply with the record retention provisions of 2 C.F.R. 200.333 (Retention requirements for records).
- 10.2. The Municipality should, whenever practicable, collect, transmit, and store Federal award-related information in open and machine readable formats rather than in closed formats or on paper in accordance with 2 C.F.R. 200.335 (Methods for collection, transmission and storage of information).

**11. ACCESS TO RECORDS.**

- 11.1. The Federal awarding agency, Inspectors General, the Comptroller General of the United States, and the County, or any of their authorized representatives, have the right of access to any documents, papers, or other records of the Municipal entity which are pertinent to the Federal award, in order to make audits, examinations, excerpts, and transcripts. The right also includes timely and reasonable access to the Municipality's personnel for the purpose of interview and discussion related to such documents. The right of access to the Municipality's records is not limited to the required retention period but last as long as the records are retained.
- 11.2. The Municipality shall permit the County and auditors to have access to the Municipality's records and financial statements as necessary for the County to meet the requirements of 2 C.F.R. Part 200.

**12. TERM.**

- 12.1. This Agreement and any amendments hereto shall be effective when executed by both Parties with concurrent resolutions passed by the governing bodies of each Party, and when the Agreement is filed according to MCL 124.510. The approval and terms of this Agreement and any amendments hereto shall be entered in the official minutes of the governing bodies of each Party. This Agreement shall end on December 31, 2023.

**13. ASSURANCES.**

- 13.1. Each Party shall be responsible for its own acts and the acts of its employees and agents, the costs associated with those acts, and the defense of those acts.
- 13.2. The Parties have taken all actions and secured all approvals necessary to authorize and complete this Agreement. The persons signing this Agreement on behalf of each Party have legal authority to sign this Agreement and bind the Parties to the terms and conditions contained herein.
- 13.3. Each Party shall comply with all federal, state, and local ordinances, regulations, administrative rules, laws, and requirements applicable to its activities performed under this Agreement.

**14. TERMINATION OF AGREEMENT.**

- 14.1. This Agreement may be terminated in whole or in part as follows:
  - 14.1.1. by the County, if the Municipality fails to comply with the terms and conditions of this Agreement;
  - 14.1.2. by the County for cause;

2023 HIGH INTENSITY DRUG TRAFFICKING AREA (HIDTA) GRANT  
SUBRECIPIENT AGREEMENT BETWEEN  
OAKLAND COUNTY  
AND  
CITY OF BIRMINGHAM

14.1.3. by the County with the consent of the Municipality, in which case the two parties must agree upon the termination conditions, including the effective date and, in the case of partial termination, the portion to be terminated;

14.1.4. by the Municipality upon sending to the County written notification setting forth the reasons for such termination, the effective date, and, in the case of partial termination, the portion to be terminated. However, if the County determines in the case of partial termination that the reduced or modified portion of the subaward will not accomplish the purpose for which this Agreement was made, the County may terminate the Agreement in its entirety.

14.2. The County must provide to the Municipality a notice of termination. Written suspension or notice of termination will be sent to the Municipality's business address. If this Agreement is terminated or partially terminated, both the County and the Municipality remain responsible for compliance with the requirements at 2 CFR 200.343 Closeout and 2 CFR 200.344 Post-closeout Adjustments and Continuing Responsibilities.

## **15. CLOSEOUT.**

15.1. The County shall close-out this Agreement when it determines that all applicable administrative actions and all required work under this Agreement have been completed by Municipality.

15.2. The Municipality shall comply with the closeout provisions of 2 C.F.R. 200.343 (Closeout).

## **16. POST-CLOSEOUT ADJUSTMENTS AND CONTINUING RESPONSIBILITIES.**

16.1. The closeout of this Agreement does not affect any of the following:

16.1.1. The right of County to disallow costs and recover funds on the basis of a later audit or other review. The County must make any cost disallowance determination and notify the Municipality within the record retention period;

16.1.2. The obligation of the Municipality to return any funds due as a result of later refunds, corrections, or other transactions including final indirect cost rate adjustments;

16.1.3. Audit requirements in Subpart F—Audit Requirements of 2 C.F.R. Part 200.

16.1.4. Records retention as required in Subpart D—Post Federal Award Requirements of this part, §200.333 Retention requirements for records through §200.337 Restrictions on public access to records.

## **17. REMEDIES FOR NONCOMPLIANCE.**

17.1. If the Municipality fails to comply with federal statutes, regulations, or the terms and conditions of this Agreement, the County may impose additional conditions, as described in 2 CFR §200.207 Specific Conditions. If the County determines that noncompliance cannot be

2023 HIGH INTENSITY DRUG TRAFFICKING AREA (HIDTA) GRANT  
SUBRECIPIENT AGREEMENT BETWEEN  
OAKLAND COUNTY  
AND  
CITY OF BIRMINGHAM

remedied by imposing additional conditions, the County may take one or more of the following actions, as appropriate in the circumstances:

- 17.1.1. temporarily withhold cash payments pending correction of the deficiency by the Municipality or more severe enforcement action by the County;
- 17.1.2. disallow (that is, deny both use of funds and any applicable matching credit for) all or part of the cost of the activity or action not in compliance;
- 17.1.3. wholly or partly suspend or terminate the Agreement;
- 17.1.4. recommend that the Federal awarding agency initiate suspension or debarment proceedings as authorized under 2 CFR Part 180 and Federal awarding agency regulations;
- 17.1.5. withhold further funds for the project or program;
- 17.1.6. take other remedies that may be legally available.

**18. NO THIRD-PARTY BENEFICIARIES.** Except as provided for the benefit of the Parties, this Agreement does not and is not intended to create any obligation, duty, promise, contractual right or benefit, right to indemnification, right to subrogation, and/or any other right, in favor of any other person or entity.

**19. DISCRIMINATION.** The Parties shall not discriminate against their employees, agents, applicants for employment, or another persons or entities with respect to hire, tenure, terms, conditions, and privileges of employment, or any matter directly or indirectly related to employment in violation of any federal, state or local law.

**20. PERMITS AND LICENSES.** Each Party shall be responsible for obtaining and maintaining, throughout the term of this Agreement, all licenses, permits, certificates, and governmental authorizations necessary to carry out its obligations and duties pursuant to this Agreement.

**21. RESERVATION OF RIGHTS.** This Agreement does not, and is not intended to waive, impair, divest, delegate, or contravene any constitutional, statutory, and/or other legal right, privilege, power, obligation, duty, or immunity of the Parties.

**22. DELEGATION/SUBCONTRACT/ASSIGNMENT.** Neither Party shall delegate, subcontract, and/or assign any obligations or rights under this Agreement without the prior written consent of the other Party.

**23. NO IMPLIED WAIVER.** Absent a written waiver, no act, failure, or delay by a Party to pursue or enforce any rights or remedies under this Agreement shall constitute a waiver of those rights with regard to any existing or subsequent breach of this Agreement. No waiver of any term, condition, or provision of this Agreement, whether by conduct or otherwise, in one or more instances, shall be deemed or construed as a continuing waiver of any term, condition, or provision of this Agreement.

No waiver by either Party shall subsequently affect its right to require strict performance of this Agreement.

**24. SEVERABILITY.** If a court of competent jurisdiction finds a term, or condition, of this Agreement to be illegal or invalid, then the term, or condition, shall be deemed severed from this Agreement. All other terms, conditions, and provisions of this Agreement shall remain in full force.

**25. CAPTIONS.** The section and subsection numbers and captions in this Agreement are intended for the convenience of the reader and are not intended to have any substantive meaning. The numbers and captions shall not be interpreted or be considered as part of this Agreement. Any use of the singular or plural number, any reference to the male, female, or neuter genders, and any possessive or nonpossessive use in this Agreement shall be deemed the appropriate plurality, gender or possession as the context requires.

**26. NOTICES.** Notices given under this Agreement shall be in writing and shall be personally delivered, sent by express delivery service, certified mail, or first-class U.S. mail postage prepaid, and addressed to the person listed below. Notice will be deemed given on the date when one of the following first occur: (1) the date of actual receipt; (2) the next business day when notice is sent express delivery service or personal delivery; or (3) three days after mailing first class or certified U.S. mail.

26.1. If Notice is sent to the County, it shall be addressed and sent to: Oakland County Board of Commissioners Chairperson, 1200 North Telegraph, Pontiac, Michigan 48341, with a copy to Oakland County Sheriff’s Office, Sheriff Fiscal Officer, 1200 N. Telegraph, Bldg. 38E, Pontiac, Michigan 48341.

26.2. If Notice is sent to the Political Subdivision, it shall be addressed to: City of Birmingham

26.3. Either Party may change the address and/or individual to which Notice is sent by notifying the other Party in writing of the change.

**27. CONTACT INFORMATION.**

<p><b><u>County of Oakland</u></b> Lieutenant Sean Jennings Investigative &amp; Forensic Services Division Narcotics Enforcement Team Office: 248-858-1722 Fax: 248-858-1754 Email: <a href="mailto:jennings@oakgov.com">jennings@oakgov.com</a></p>	<p><b><u>City of Birmingham</u></b> Captain Chris Koch Birmingham Police Department 151 Martin Birmingham, MI 48009 248-530-1769 Email: <a href="mailto:ckoch@bhamgov.org">ckoch@bhamgov.org</a></p>
--	--

**28. GOVERNING LAW.** This Agreement shall be governed, interpreted, and enforced by the laws of the State of Michigan, without regard to Michigan’s conflict of laws provisions.

**29. AGREEMENT MODIFICATIONS OR AMENDMENTS.** Any modifications, amendments, rescissions, waivers, or releases to this Agreement must be in writing and executed by both Parties.

**30. ENTIRE AGREEMENT.** This Agreement represents the entire agreement and understanding between the Parties. This Agreement supersedes all other oral or written agreements between the Parties. The language of this Agreement shall be construed as a whole according to its fair meaning, and not construed strictly for or against any Party.

**IN WITNESS WHEREOF,** David T. Woodward, Chairperson, Oakland County Board of Commissioners, acknowledges that he has been authorized by a resolution of the Oakland County Board of Commissioners, a certified copy of which is attached, to execute this Agreement, and hereby accepts and binds the County to the terms and conditions of this Agreement.

EXECUTED: \_\_\_\_\_ DATE: \_\_\_\_\_  
David T. Woodward, Chairperson  
Oakland County Board of Commissioners

WITNESSED: \_\_\_\_\_ DATE: \_\_\_\_\_  
Printed Name:  
Title:

**IN WITNESS WHEREOF,** \_\_\_\_\_, acknowledges that he/she has been authorized by a resolution of the Municipality’s governing body, a certified copy of which is attached, to execute this Agreement, and hereby accepts and binds the Municipality to the terms and conditions of this Agreement.

EXECUTED: \_\_\_\_\_ DATE: \_\_\_\_\_  
Printed Name:  
Title:

WITNESSED: \_\_\_\_\_ DATE: \_\_\_\_\_  
Printed Name:  
Title:



## **MEMORANDUM**

Clerk's Office

**DATE:** June 5, 2023

**TO:** Thomas M. Markus, City Manager

**FROM:** Alexandria Bingham, City Clerk

**SUBJECT:** SOCRRA Board of Trustees Representatives

---

### **INTRODUCTION:**

Article VII of the Articles of Incorporation of South Oakland County Resource Recovery Authority (SOCRRA) provides that each member municipality shall annually appoint a representative and an alternate to the Board of Trustees.

### **BACKGROUND:**

Since 2015 the City Commission has appointed the City Manager as the Representative and the DPS Director as the Alternate.

### **LEGAL REVIEW:**

n/a

### **FISCAL IMPACT:**

n/a

### **PUBLIC COMMUNICATIONS:**

Information regarding this appointment will be provided along with the agenda packet on the city website. Public comment is welcome in accordance with standard commission procedure.

### **SUMMARY:**

The City Commission is being asked to appoint Jana Ecker as the Primary Representative and Scott Zielinski as the Alternate Representative to the SOCRRA Board of Trustees for the 2023-2024 fiscal year.



ATTACHMENTS:

May 2, 2023 letter from SOCRRA

SUGGESTED COMMISSION ACTION:

Make a motion adopting a resolution to appoint Jana Ecker as Representative and Scott Zielinski as Alternate Representative of the City of Birmingham on the SOCRRA Board of Trustee for the fiscal year starting July 1, 2023.



May 2, 2023

Alexandria Bingham  
City Clerk  
City of Birmingham  
P.O. Box 3001  
Birmingham, MI 48012

Subject: Appointment of Representative & Alternate

Dear Ms. Bingham:

Article VII of the Articles of Incorporation of SOCRRA provides that each municipality shall annually appoint a representative and an alternate to the Board of Trustees. This representative shall serve during the next fiscal year following his appointment and/or until his successor is appointed.

The present representative and alternate representative for the City of Birmingham are as follows:

Representative

Alternate

T. Markus

S. Zielinski

It is requested that the City Commission, by resolution, appoint a representative and alternate representative to represent the City of Birmingham on the Board of Trustees of SOCRRA for the fiscal year beginning July 1, 2023.

Please forward a certified copy of this resolution to SOCRRA, 3910 W. Webster Road, Royal Oak, MI 48073-6764.

Very truly yours,

Jeffrey A. McKeen, P.E.  
General Manager

JAM/cf



## **MEMORANDUM**

Clerk's Office

**DATE:** June 5, 2023  
**TO:** Thomas M. Markus, City Manager  
**FROM:** Alexandria Bingham, City Clerk  
**SUBJECT:** SOCWA Board of Trustees

---

### INTRODUCTION:

Article VII of the Articles of Incorporation of Southeastern Oakland County Water Authority (SOCWA) provides that each member municipality shall annually appoint a representative and an alternate to the Board of Trustees.

### BACKGROUND:

Historically, the City Commission has appointed the City Engineer as the Representative and Assistant City Engineer as the Alternate.

### LEGAL REVIEW:

n/a.

### FISCAL IMPACT:

n/a

### PUBLIC COMMUNICATIONS:

Information regarding this appointment will be provided along with the agenda packet on the city website. Public comment is welcome in accordance with standard commission procedure.

### SUMMARY:

The City Commission is being asked to appoint Melissa Coatta to the SOCWA Board of Trustees as the Primary Representative and Jana Ecker as the Alternate Representative for the 2023-2024 fiscal year.

ATTACHMENTS:

May 2, 2023 letter from SOCWA

SUGGESTED COMMISSION ACTION:

Make a motion adopting a resolution to appoint Melissa Coatta as Representative and Jana Ecker as Alternate Representative of the City of Birmingham on the SOCWA Board of Trustees for the fiscal year starting July 1, 2023.



\* Berkley \* Beverly Hills \* Bingham Farms \* Birmingham  
\* Clawson \* Huntington Woods \* Lathrup Village \* Pleasant Ridge  
\* Royal Oak \* Southfield \* Southfield Township

May 2, 2023

Alexandria Bingham  
City Clerk  
City of Birmingham  
P.O. Box 3001  
Birmingham, MI 48012

Subject: Appointment of Representative & Alternate

Dear Ms. Bingham:

Article VII of the Articles of Incorporation of the Southeastern Oakland County Water Authority provides that each municipality shall annually appoint a representative and an alternate to the Board of Trustees. This representative shall serve during the next fiscal year following his appointment and/or until his successor is appointed.

The present representative and alternate representative for the City of Birmingham are as follows:

Representative

Alternate

M. Coatta

T. Markus

It is requested that the City Commission, by resolution, appoint a representative and alternate representative to represent the City of Birmingham on the Board of Trustees of the Southeastern Oakland County Water Authority for the fiscal year beginning July 1, 2023.

Please forward a certified copy of this resolution to the Southeastern Oakland County Water Authority, 3910 W. Webster Road, Royal Oak, MI 48073-6764.

Very truly yours,

Jeffrey A. McKeen, P.E.  
General Manager

JAM/cf



## **MEMORANDUM**

Clerk's Office

**DATE:** April 24, 2023  
**TO:** Thomas M. Markus, City Manager  
**FROM:** Christina Woods, Deputy City Clerk  
**APPROVED:** Alexandria Bingham, City Clerk  
**SUBJECT:** Public Arts Board Member Resignation

---

### **INTRODUCTION/BACKGROUND:**

The Public Arts Board Regular Member Jane Schulak submitted her resignation from the board effective April 21, 2023. This creates a vacancy for the remainder of her three-year term to expire January 28, 2025.

### **LEGAL REVIEW:**

None

### **FISCAL IMPACT:**

None

### **PUBLIC COMMUNICATIONS:**

The City Clerk's office will publish a notice of intention to appoint to this position, post the vacancy on the "board and commission opportunities" portion of the city's website and include it in the city's digital news vehicles as publication schedules permit.

### **SUMMARY:**

The City Commission is being asked to accept the resignation of Jane Schulak from the Public Arts Board, thank her for her service, and to direct the City Clerk to begin the process of filling the vacancy.

### **ATTACHMENTS:**

1. Resignation email dated 4/21/2023

### **SUGGESTED COMMISSION ACTION:**

To make a motion to accept the resignation of Jane Schulak from the Public Arts Board, to thank her for her service and to direct the City Clerk to begin the process of filling the vacancy.

---

## Fwd: PAB membership

3 messages

---

**Brooks Cowan** <bcowan@bhamgov.org>

Fri, Apr 21, 2023 at 2:48 PM

To: Alex Bingham <abingham@bhamgov.org>, Christina Woods <cwoods@bhamgov.org>

Jane Schulak's resignation from PAB email below.

----- Forwarded message -----

From: **Jane Schulak** <jane@schulak.com>

Date: Fri, Apr 21, 2023 at 2:46 PM

Subject: Re: PAB membership

To: Brooks Cowan <bcowan@bhamgov.org>

Dear Brooks,

It is with deep regrets that I need to resign from the Birmingham Arts Board. I am currently engaged in a large collaboration with the global taste making for Christie's as well as the Museum of Decorative Arts in Paris - leaving me little time for the local engagement. I would always be available to advise as needed and wish the team much success.

With kind regards,

Jane Schulak

> On Apr 19, 2023, at 6:35 PM, Brooks Cowan <bcowan@bhamgov.org> wrote:

>

> Hi Jane,

>

> No worries about conflicting schedules - it's tough to make midweek evening meetings. If you don't think you'll be able to make meetings on a consistent basis then I think it's best to resign and allow others an opportunity to join.

>

> resignation just requires an email to me - I can forward it to the Clerk to finalize.

>

> Thanks

>

> --

> Brooks Cowan

> Senior Planner

> (248) 530-1846

--

Brooks Cowan

Senior Planner

(248) 530-1846

---

**Christina Woods** <cwoods@bhamgov.org>

Fri, Apr 21, 2023 at 3:38 PM

To: Brooks Cowan <bcowan@bhamgov.org>

Cc: Alex Bingham <abingham@bhamgov.org>

I'll get a resignation and intention to appoint on the 5/8 meeting. Thank you!



## **MEMORANDUM**

Engineering Department

**DATE:** May 8, 2023

**TO:** Thomas M. Markus, City Manager

**FROM:** Melissa A. Coatta, City Engineer

**SUBJECT:** Brown Street Paving  
Hearing of Necessity for Sidewalk and Streetscape Special Assessment District (SAD)

---

### INTRODUCTION:

The design has been completed and bids were accepted on Tuesday, May 2, 2023 for the Brown Street Paving Project, which includes the reconstruction of Brown Street from S. Old Woodward to Woodward Ave. The proposed work includes new sidewalk and streetscape features to match what was previously completed along Old Woodward and Maple Road.

### BACKGROUND:

The Michigan Department of Transportation (MDOT) will improve pedestrian crossings at Woodward Ave. and Brown/Forest intersections starting in September 2023. The City Commission approved the reconfiguration of Brown Street from S. Old Woodward to Woodward Ave. to include a reduction of one lane eastbound at Woodward Ave., a midblock pedestrian crossing, and an additional median island west of Peabody Street.

The new streetscape on Brown Street will include:

- Enhanced version of the downtown standard sawcut concrete sidewalk with an exposed aggregate sidewalk between the main pedestrian sidewalk and the street curb.
- Professional-designed landscaping that includes enlarged raised planter beds framed by a 6-inch exposed aggregate curb, new street trees, and irrigation.

The proposed project is scheduled to start construction June 2023, with substantial project completion by August 4, 2023, and final project completion by August 18, 2023.

The City's policy has been to assess 75% of the streetscape improvements to the properties that share frontage with the improvements. The cost per property will be assessed as an average cost per linear foot of frontage for the improvements. The properties with multiple owners will share the cost of the frontage, and the amount will be based on the square footage of the building area



owned. The City will bill one-tenth of the assessment, as would be done on other special assessment districts, plus interest, on an annual basis, to make the cost more manageable for the property owners.

The parcels within the project zone that are subject to the sidewalk and street scape are highlighted on the attached map. Appended to this report is a list of properties that the department plans to include in the assessment district, along with estimated construction costs.

**LEGAL REVIEW:**

Chapter 94 – Special Assessments of the Birmingham City Code outlines the process by which a special assessment is conducted in the City of Birmingham. This project will follow the prescribed City Code procedures. Legal has reviewed and found no issues.

**FISCAL IMPACT:**

Revenues generated from the Streetscape SAD for the Brown Street Paving will defray the costs incurred by the City for the construction of these improvements. Consistent with previous projects of this nature, the City's policy is as follows:

- 75% of the streetscape improvements to the properties that share frontage with the improvements.
- Properties with multiple owners will share the cost of the frontage, and the amount will be based on the square footage of the building area owned.

The City pays for the balance of the costs, 25% of the streetscape improvements.

**PUBLIC COMMUNICATIONS:**

The Engineering Department held a property owner meeting on Thursday, March 23, 2023 to discuss the project, traffic access during construction, and special assessment.

Notice for the Confirmation of Roll is to be distributed by the Clerk's Office. The Engineering Department has sent all property owners a letter explaining the associated work.

The Engineering Department did receive phone calls from property owners with questions and proposed construction schedule.

**SUMMARY:**

The Engineering Department recommends that the City Commission declare necessity and approve a Special Assessment District for the Brown Street Paving. Should the Commission approve the Special Assessment District, a public hearing for confirmation of the roll will be held at the City Commission meeting on May 22, 2023.

**ATTACHMENTS:**

- Map of proposed Streetscape Special Assessment District (1 page)
- Brown Street Paving Plans (33 pages)
- Spreadsheet with Estimated Costs of Services (2 pages)
- Clerk's Confirmation of Public Hearing Notice (7 pages)

**SUGGESTED COMMISSION ACTION:**

- WHEREAS, Notice was given pursuant to Section 94-7 of the City Code, to each owner or party-in-interest of property and lots to be assessed, by first class mail, and by publication in a newspaper generally circulated in the City; and
- WHEREAS, The City Commission has conducted a public hearing and has determined to proceed with the project of replacing sidewalks, reconfiguring roadway, and streetscape on Brown Street from S. Old Woodward to Woodward Ave.; and
- WHEREAS, The City has previously established a policy requiring replacement or improvement of sidewalks and streetscape when the City street is open for repairs or reconstruction in the Central Business District; and
- WHEREAS, The City Commission, after the public hearing, has determined that the Brown Street Paving Project is a necessity and is in the best interest of the City; and
- WHEREAS, The Commission has approved the detailed plans and estimates of cost prepared by the City Engineer; and
- WHEREAS, Formal bids have been received and the actual cost for sidewalk and streetscape has been determined; and
- WHEREAS, The City Engineer has determined the boundaries of sidewalk and streetscape located within the limits of the following streets shall be installed as part of the Brown Street Paving Project (Contract #5-23(P)):
- Brown Street – S. Old Woodward to Woodward Ave.; and
- WHEREAS, The formula used in making the assessment is 75% of the contractor’s charge for replacing sidewalks, reconfiguring roadway, and streetscape (calculated at the rate of \$853.68 per foot of frontage property).

THEREFORE LET It BE RESOLVED, The City Commission has determined that the scope of the public improvement as described is in the best interest of the City and will benefit the properties listed in the assessment roll, and the City Commission directs the Manager to prepare a Special Assessment Roll and present the same to the Commission for confirmation and further set a Public Hearing and give notice on May 22, 2023.

<b>Parcel ID</b>	<b>Street Address</b>	<b>Parcel ID</b>	<b>Street Address</b>
08-19-36-208-015	325 S Old Woodward	08-19-36-206-021	255 S Old Woodward
08-19-36-208-016	355 S Old Woodward	08-19-36-207-010	34901 Woodward
08-19-36-208-004	34745 Woodward	08-19-36-206-024	Chester Parking Structure
08-19-36-206-023	Alley		

# Brown Street Sidewalk and Streetscape SAD



- 2 Foot Contours
- 5 Foot Contours
- FEMA Base Flood Elevations
- FEMA Cross Sections
- 100 yr - FEMA Floodplain
- 100 yr (detailed) - FEMA Floodplain
- 500 yr - FEMA Floodplain
- FLOODWAY - FEMA Floodplain

Disclaimer: The information provided herewith has been compiled from recorded deeds, plats, tax maps, surveys and other public records. It is not a legally recorded map or survey and is not intended to be used as one. Users should consult the information sources mentioned above when questions arise. FEMA Floodplain data may not always be present on the map.

**OAKLAND**  
 COUNTY OF MICHIGAN  
 Economic Development & Community Affairs  
**David Coulter**  
 Oakland County Executive

Date Created: 4/18/2023  
  
**NORTH**  
 1 inch = 100 feet

**7A**

**SHEET INDEX**

- COVER SHEET  
 T1 TOPOGRAPHIC SURVEY - BROWN STREET STA. P.O.B. TO 2+82  
 T2 TOPOGRAPHIC SURVEY- BROWN STREET STA. 2+82 TO P.O.E.  
 C1 UTILITY PLAN - BROWN STREET STA. P.O.B. TO 2+82  
 C2 UTILITY PLAN - BROWN STREET STA. 2+82 TO P.O.E.  
 C3 STORM PROFILE PLAN  
 C4 GRADING PLAN - BROWN STREET STA. P.O.B. TO 2+82  
 C5 GRADING PLAN - BROWN STREET STA. 2+82 TO P.O.E.  
 C6 INTERSECTION GRADING DETAIL (1 OF 2)  
 C7 INTERSECTION GRADING DETAIL (2 OF 2)  
 C8 PAVING PLAN - BROWN STREET STA. P.O.B. TO P.O.E.  
 C9 EXISTING AND PROPOSED CROSS-SECTION  
 C10 STRIPING AND SIGNAGE PLAN  
 C11 BROWN STREET DETOUR PLAN  
 C12 PEDESTRIAN ACCESS & TRAFFIC CONTROL PLAN  
 C13 NOTES AND DETAILS(1 OF 2)  
 C14 NOTES AND DETAILS(2 OF 2)

IRRIGATION PLANS

- IR 1.0 IRRIGATION DESIGN  
 IR 1.1 IRRIGATION DETAILS

LANDSCAPE PLANS

- L0.0 PLANT SCHEDULE AND NOTES  
 L1.0 OVERALL LANDSCAPE PLAN  
 L1.1 LANDSCAPE PLAN  
 L1.2 LANDSCAPE PLAN  
 L1.3 LANDSCAPE DETAILS  
 L1.4 LANDSCAPE DETAILS  
 L1.5 DECORATIVE FENCE ALTERNATE  
 L2.0 SOILS PLAN  
 L2.1 SOILS PLAN

Q1 QUANTITIES

CITY OF BIRMINGHAM STANDARD DETAILS

- CBD STREETSCAPE STANDARD DETAILS  
 SIDEWALK RAMPS AND BRICK PAVER SIDEWALKS  
 SEWER STANDARD DETAILS  
 WATER MAIN STANDARD DETAILS

**UTILITY NOTE**

THE LOCATIONS AND ELEVATIONS OF SOME OF THE EXISTING UNDERGROUND UTILITIES AS SHOWN ON THE SURVEY DRAWING WERE OBTAINED FROM MUNICIPAL AND UTILITY COMPANY RECORDS AND MAPS. THEREFORE, NO GUARANTEE IS EITHER EXPRESSED OR IMPLIED AS TO THE COMPLETENESS OR ACCURACY THEREOF. THE CONTRACTOR SHALL BE RESPONSIBLE FOR DETERMINING THE EXACT UTILITY LOCATIONS AND ELEVATIONS PRIOR TO THE START OF CONSTRUCTION.

**CIVIL ENGINEER**

NOWAK & FRAUS ENGINEERS  
 46777 WOODWARD AVENUE  
 PONTIAC, MI 48342  
 CONTACT: MR. BRETT BUCHHOLZ, P.E.  
 CONTACT: MR. PAUL TULIKANGAS, P.E.  
 PHONE: (248) 332-7931  
 EMAIL: BBUCHHOLZ@NFE-ENGR.COM  
 EMAIL: PTULIKANGAS@NFE-ENGR.COM

**LANDSCAPE ARCHITECT**

MKSK  
 4219 WOODWARD AVE., STE. 305  
 DETROIT, MI 48201  
 CONTACT: MS. KRISTYN BOWDEN PLA, LEED GA  
 PHONE: (419) 283-6934  
 EMAIL: KBOWDEN@MKSKSTUDIOS.COM



**BENCHMARK NOTE**

BENCHMARKS SET AND SHOWN PER SHEET WERE ESTABLISHED OFF OF THE CITY OF BIRMINGHAM BENCHMARK DATUM.



ENGINEERING DEPARTMENT  
**BROWN STREET PAVING PROJECT**  
 CONTRACT #5-23(P)

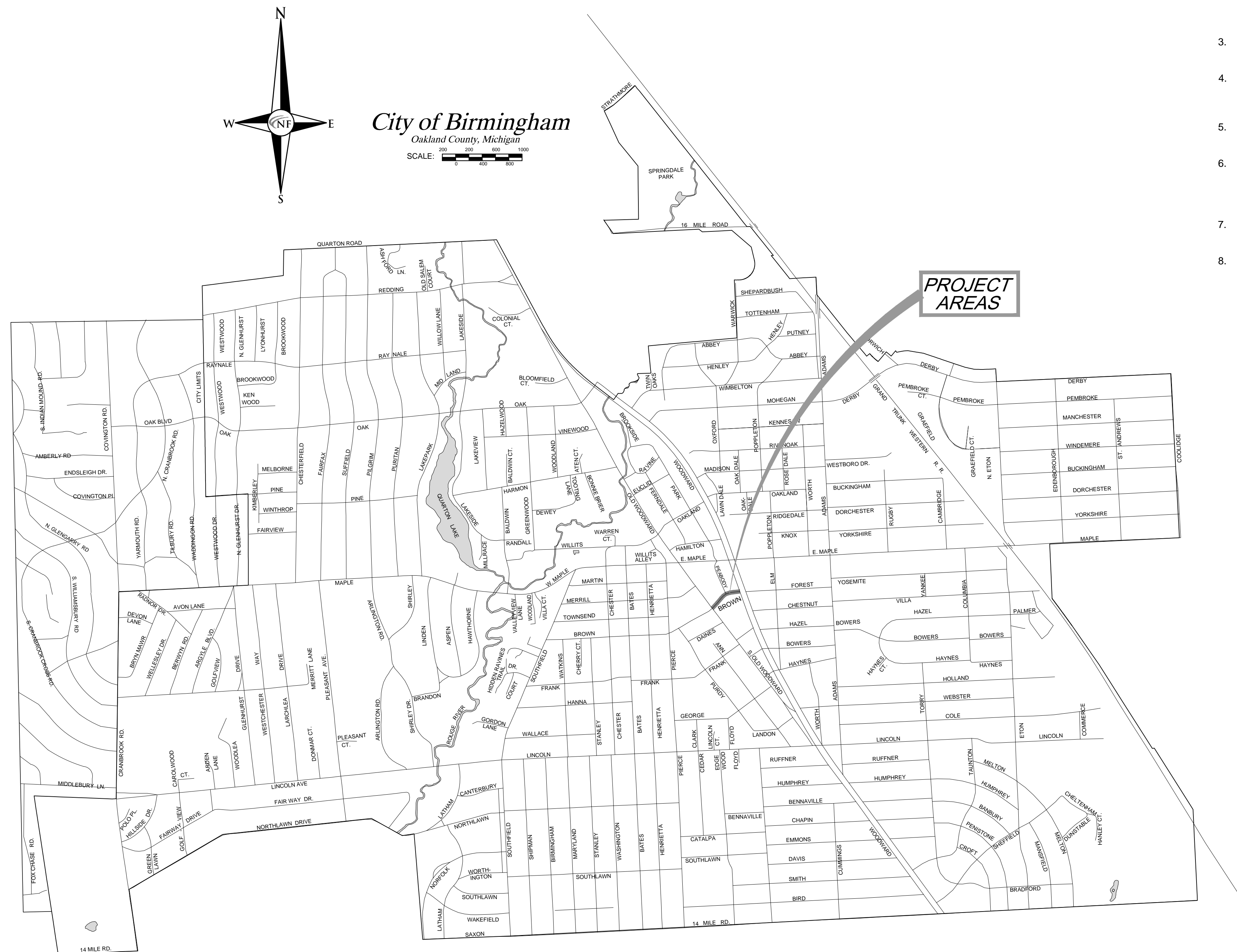
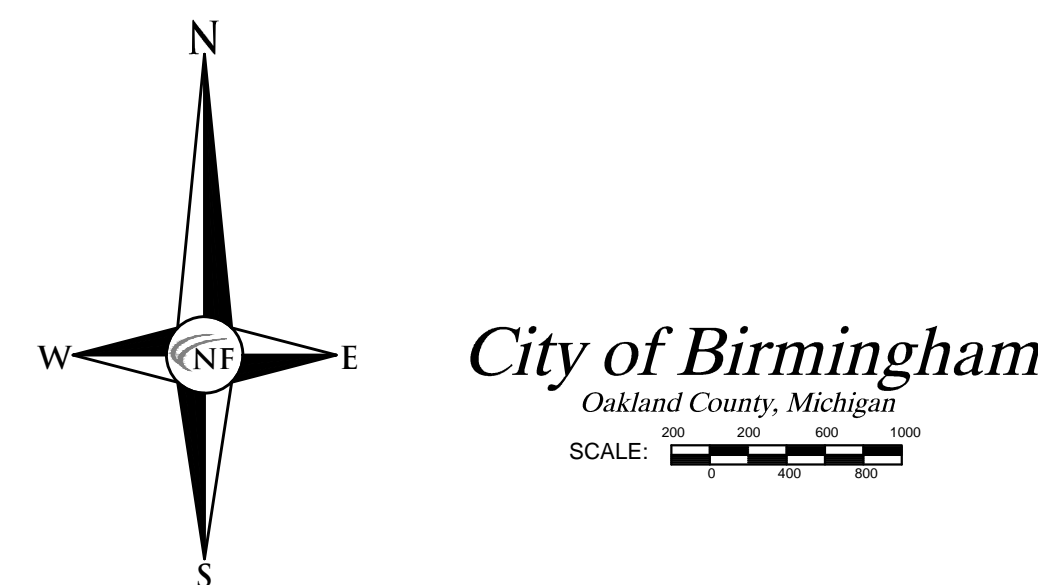

These notes shall apply for all work within this contract:

- The contractor shall notify MISS DIG 1-800-482-7171 at least 3 working days excluding Saturday, Sunday, and Holidays before making any excavations and notify the City of Birmingham Engineering Department a minimum of 24 hours prior to the start of construction (248-530-1850).
- See the City of Birmingham drawings "Sewer Standard Details" and "Water Main Standard Details" for details of manholes, catch basins, inlets, and related sewer and water main work.
- All excavation under or within three feet of pavement, public or private, shall be backfilled and compacted with sand.
- The joints at the edges of all excavations in the pavement shall be sawcut, or pavement will be removed to existing joints, as directed by the Engineer. There is no separate pay item for saw cutting pavements.
- The contractor shall be responsible for damage to existing utilities, pavement, trees, landscaping, gravel, etc., whether located on public or private property.
- Catch basin and inlet castings scheduled for replacement, or new construction shall be EJIW 5000Z4 DI / 5000M4 DI Hinged Assembly unless specified otherwise. Manhole castings shall be EJIW 1040-A cover as noted on the detail sheets and plans, unless otherwise specified.
- Storm, sewer and water main trench shall be backfilled with MDOT Class II sand and properly compacted to 95% of modified proctor density.
- The contractor shall coordinate and cooperate with all other utility companies working in the same area, project related or not, during the same allotted construction period.

**ALL WATER SERVICE, STORM AND SEWER TRENCH SHALL BE BACKFILLED WITH COMPACTED GRANULAR CLASS II (SAND) MATERIAL.**

**CAUTION!!! LIVE WATER MAIN**  
 PRIOR TO CUTTING IN NEW MAIN FITTINGS, THE CONTRACTOR SHALL BE RESPONSIBLE FOR COORDINATING THE EXISTING WATER MAIN SHUT-DOWN WITH THE CITY. MORE IMPORTANTLY, THE CONTRACTOR SHALL BE RESPONSIBLE FOR SAFELY ENSURING THAT PRESSURES DO NOT EXIST IN THE MAIN AFTER SHUT-DOWN & PRIOR TO CUTTING THE MAIN. IF REQUIRED, THE CONTRACTOR SHALL UTILIZE A HYDRO-STOP DEVICE TO CLOSE OFF FLOW WHILE CUTTING IN NEW TEE.

**BROWN STREET PAVING PROJECT CONTRACT #5-23(P)**

APPROVED \_\_\_\_\_ DATE \_\_\_\_\_

SEAL

PROJECT  
Brown Street Paving Project

CLIENT



Engineering Department  
151 Martin Street  
Birmingham, MI 48012

PROJECT LOCATION  
Part of the Northeast 1/4  
of Section 36  
Town 2 North,  
Range 10 East  
City of Birmingham,  
Oakland County, Michigan

SHEET  
Topographic Survey  
Sta. P.O.B. to Sta. 2+82



DATE ISSUED/REVISED  
12-08-22 ISSUED SURVEY

TOPOGRAPHIC SURVEY NOTES  
ALL ELEVATIONS ARE EXISTING ELEVATIONS, UNLESS OTHERWISE NOTED.  
UTILITY LOCATIONS WERE OBTAINED FROM MUNICIPAL OFFICIALS AND RECORDS OF UTILITY COMPANIES, AND NO GUARANTEE CAN BE MADE TO THE COMPLETENESS, OR EXACTNESS OF LOCATION.  
THIS SURVEY MAY NOT SHOW ALL EASEMENTS OF RECORD UNLESS AN UPDATED TITLE POLICY IS FURNISHED TO THE SURVEYOR BY THE OWNER.

DRAWN BY:  
G. Viju  
DESIGNED BY:  
B. Buchholz  
APPROVED BY:  
DATE:  
December 08, 2022  
SCALE: 1" = 20'  
NFE JOB NO. SHEET NO.  
D162-01 T1

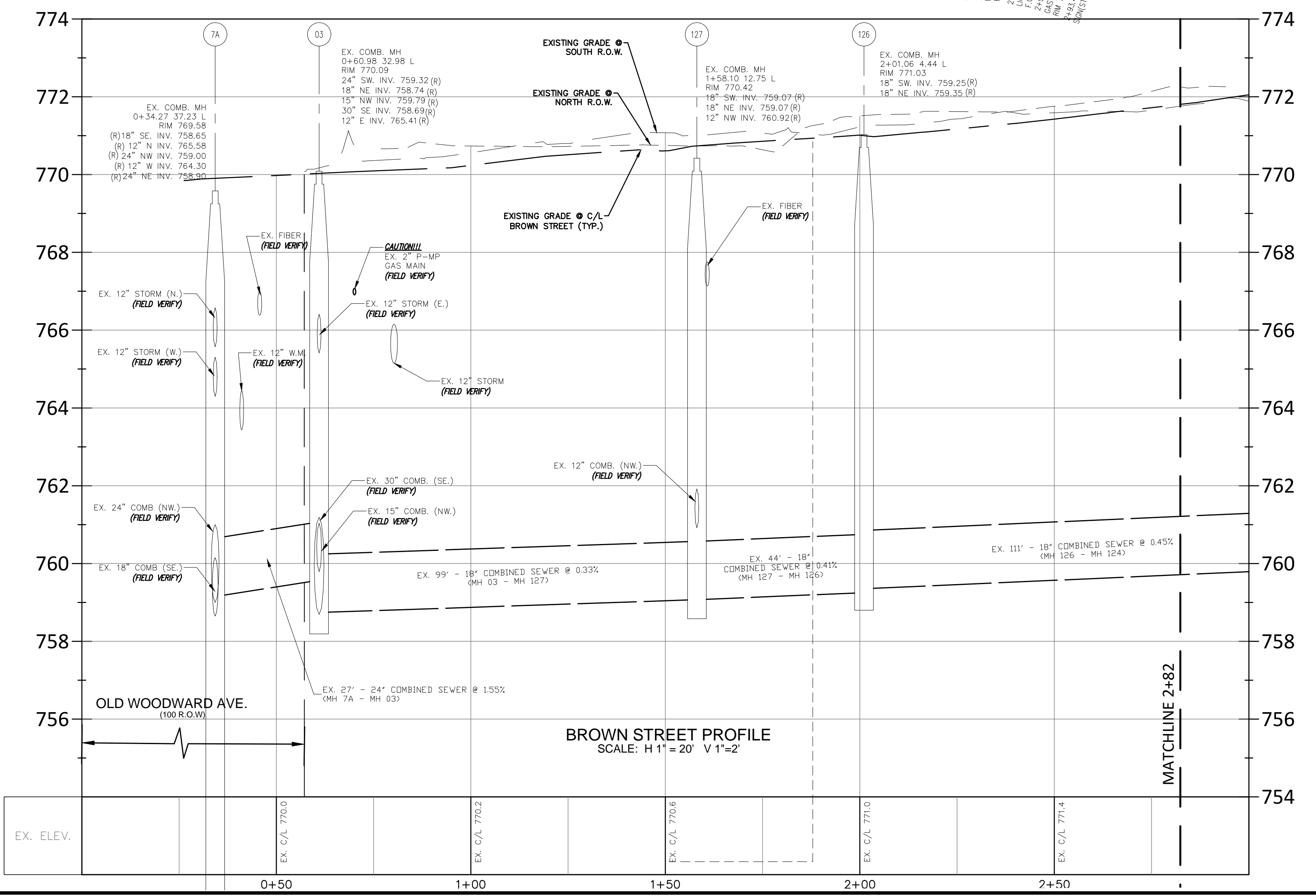
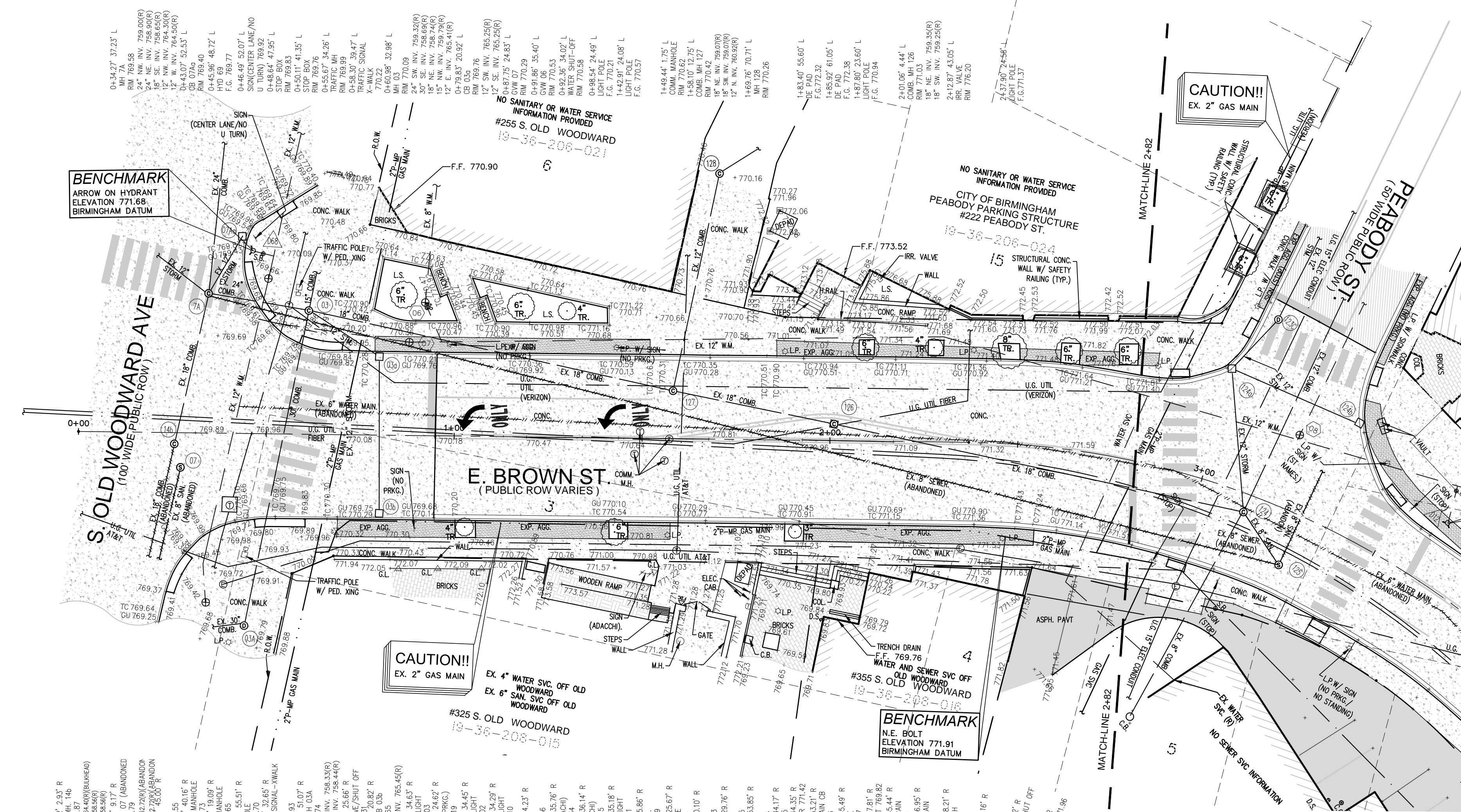

**LEGEND**

	MANHOLE		EXISTING SANITARY SEWER
	HYDRANT		EXISTING SAN. CLEAN OUT
	MANHOLE CATCH BASIN		EXISTING STORM SEWER
	UTILITY POLE		EX. R.Y. CATCH BASIN
	GUY WIRE		EXISTING BURIED CABLES
	OVERHEAD LINES		LIGHT POLE
	SIGN		EXISTING GAS MAIN

SEAL

PROJECT  
Brown Street Paving Project



Engineering Department  
151 Martin Street  
Birmingham, MI 48012

PROJECT LOCATION  
Part of the Northeast 1/4  
of Section 36  
Town 2 North  
Range 10 East  
City of Birmingham,  
Oakland County, Michigan

SHEET  
Topographic Survey  
Sta. 2+82 to Sta. P.O.E.



Know what's below  
Call before you dig.

DATE ISSUED/REVISED  
12-08-22 ISSUED SURVEY

### MISS DIG / UTILITY DISCLAIMER NOTE

A MISS DIG TICKET NUMBER 2022101901728, PURSUANT TO MICHIGAN PUBLIC ACT 174 WAS ENTERED FOR THE SURVEYED PROPERTY DUE TO THE EXTENDED REPORTING PERIOD FOR UNDERGROUND FACILITY OWNERS TO PROVIDE THEIR RECORDS, THE SURVEY MAY NOT REFLECT ALL THE UTILITIES AT THE TIME THE SURVEY WAS ISSUED ON 12/08/2022. THE SURVEY ONLY REFLECTS THOSE UTILITIES WHICH COULD BE OBSERVED BY THE SURVEYOR IN THE FIELD OR AS DEPICTED BY THE UTILITY COMPANY RECORDS FURNISH PRIOR TO THE DATE THIS SURVEY WAS ISSUED. THE CLIENT AND/OR THEIR AUTHORIZED AGENT SHALL VERIFY WITH THE FACILITY OWNERS AND/OR THEIR AUTHORIZED AGENTS, THE COMPLETENESS AND EXACTNESS OF THE UTILITIES LOCATION.

### TOPOGRAPHIC SURVEY NOTES

ALL ELEVATIONS ARE EXISTING ELEVATIONS, UNLESS OTHERWISE NOTED.

UTILITY LOCATIONS WERE OBTAINED FROM MUNICIPAL OFFICIALS AND RECORDS OF UTILITY COMPANIES, AND NO GUARANTEE CAN BE MADE TO THE COMPLETENESS, OR EXACTNESS OF LOCATION.

THIS SURVEY MAY NOT SHOW ALL EASEMENTS OF RECORD UNLESS AN UPDATED TITLE POLICY IS FURNISHED TO THE SURVEYOR BY THE OWNER.

LEGEND	
	MANHOLE
	HYDRANT
	MANHOLE
	UTILITY POLE
	GUY POLE
	GUY WIRE
	LIGHT POLE
	SIGN
	EXISTING SANITARY SEWER
	EXISTING SAN. CLEAN OUT
	EXISTING WATER MAIN
	EXISTING STORM SEWER
	EX. R.Y. CATCH BASIN
	EXISTING BURIED CABLES
	OVERHEAD LINES
	LIGHT POLE
	SIGN
	EXISTING GAS MAIN

DRAWN BY:  
G. Viju

DESIGNED BY:

APPROVED BY:  
B. Buchholz

DATE:  
December 08, 2022

SCALE: 1" = 20'

NFE JOB NO. 12162-01

sheet no. T2

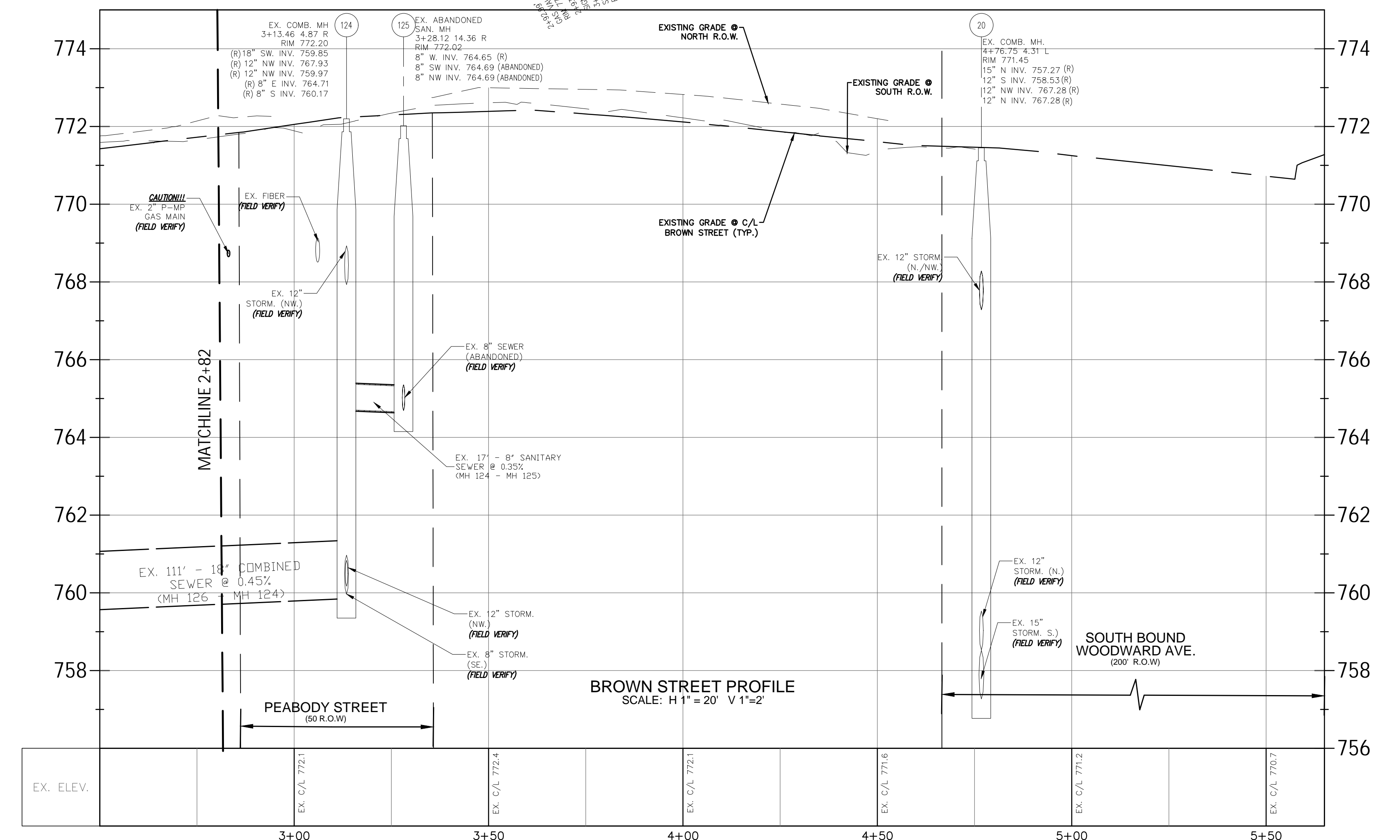
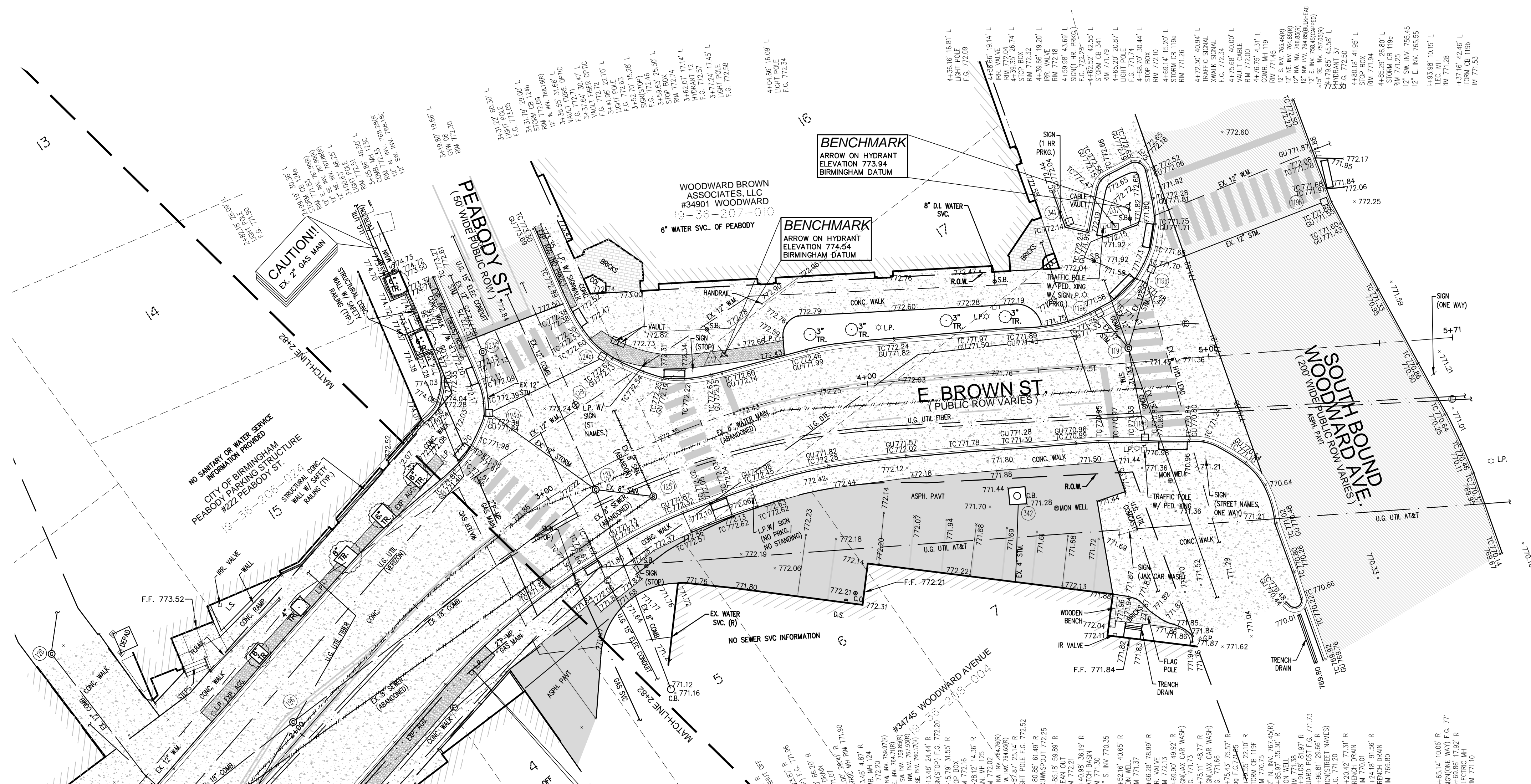

SEAL

PROJECT  
 Brown Street Paving Project  
 Contract # 5-23(P)

CLIENT



Engineering Department  
 151 Martin Street  
 Birmingham, MI 48012

PROJECT LOCATION  
 Part of the Northeast 1/4  
 of Section 36  
 Town 2 North,  
 Range 10 East  
 City of Birmingham,  
 Oakland County, Michigan

SHEET  
 Utility Plan (1 of 2)  
 Sta. P.O.B. to 2+82



Know what's below  
 Call before you dig.

DATE	ISSUED/REVISED
12-08-22	ISSUED SURVEY
02-04-23	CONCEPT PLAN
02-14-23	UPDATED CONCEPT PLAN
03-16-23	90% CITY REVIEW
04-10-23	RIDS
04-26-23	ADDENDUM 1

DRAWN BY:  
 G. Viju  
 DESIGNED BY:  
 G. Viju  
 APPROVED BY:  
 B. Buchholz

DATE:  
 March 16, 2023

SCALE: 1" = 20'

NFE JOB NO. SHEET NO.  
 D162-01 C1

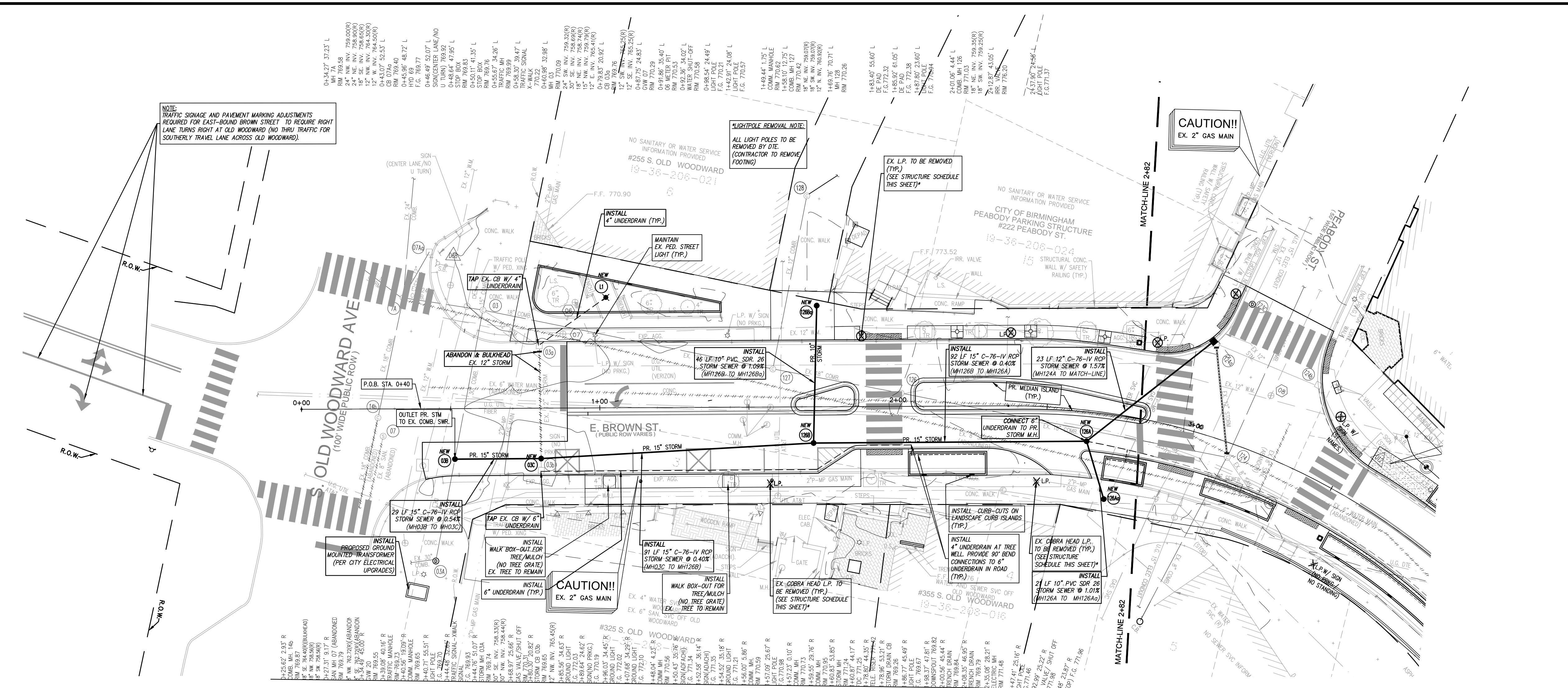
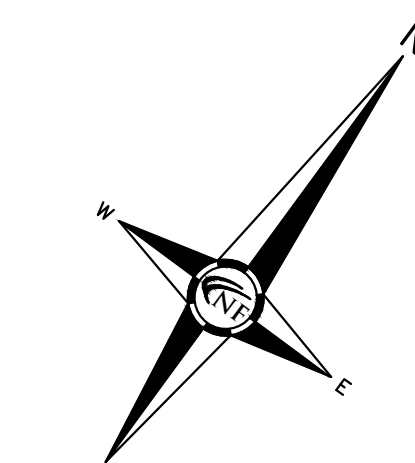

**EX. STREET LIGHT REMOVAL SCHEDULE**  
 E. BROWN STREET, P.O.B. TO 2+82

NORTH		
STATION	OFFSET	ITEM
STA. 1+37.68	23.60' N.	PEDESTRIAN STREET LIGHT
STA. 2+38.66	24.57' N.	PEDESTRIAN STREET LIGHT

SOUTH		
STATION	OFFSET	ITEM
STA. 1+57.01	25.70' S.	COBRA HEAD LIGHT POLE
STA. 2+47.40	25.16' S.	COBRA HEAD LIGHT POLE

**UTILITY NOTE**  
 THE LOCATIONS AND ELEVATIONS OF SOME OF THE EXISTING UNDERGROUND UTILITIES AS SHOWN ON THE SURVEY DRAWING WERE OBTAINED FROM MUNICIPAL AND UTILITY COMPANY RECORDS AND MAPS. THEREFORE, NO GUARANTEE IS EITHER EXPRESSED OR IMPLIED AS TO THE COMPLETENESS OR ACCURACY THEREOF. THE CONTRACTOR SHALL BE RESPONSIBLE FOR DETERMINING THE EXACT UTILITY LOCATIONS AND ELEVATIONS PRIOR TO THE START OF CONSTRUCTION.

**Pr. Storm Sewer Structure Schedule**

Structure Name	Structure Details
#03B 6" DIA MANHOLE CONSTRUCT ONLINE (RE-CONNECT EX. 30" N.W. & S.E.) (FIELD VERIFY INVERT)	PR. RIM 769.80 EX. 30" NW. INV. 758.54 PR. 15" NE. INV. 763.50 EX. 30" SE. INV. 758.54
#03C PR. 4" DIA STORM MANHOLE W/ 2' SUMP CONSTRUCT ONLINE (RE-CONNECT EX. 12" STORM SE. INV. 765.43 - FIELD VERIFY)	PR. RIM 770.04 PR. 15" NE. INV. 763.76 PR. 15" SW. INV. 763.66 EX. 12" SE. INV. 765.43 INSTALL P.V.C. GAS TRAP ON 15" DOWNSTREAM PIPE (S.W.)
#126A PR. 4" DIA STORM MANHOLE	PR. RIM 772.05 PR. 12" N. INV. 766.85 PR. 15" SW. INV. 764.59 PR. 10" SE. INV. 766.85 PR. 6" NE. INV. 768.70
#126Aa (FOR FUTURE SE CONNECTION)	PR. RIM 771.59 PR. 10" NW. INV. 767.05
#126B PR. 4" DIA STORM MANHOLE	PR. RIM 770.98 PR. 15" NE. INV. 764.22 PR. 10" NW. INV. 764.12 PR. 30" NW. INV. 765.75
#126Ba PR. 4" DIA. M.H. (FOR FUTURE NW CONNECTION)	PR. RIM 770.70 PR. 10" SE. INV. 766.25
#11 PR. 12" DIA. LANDSCAPE DRAIN W/ CAST-IRON BEE-HIVE COVER	PR. RIM 770.66 PR. 4" S. INV. 767.50

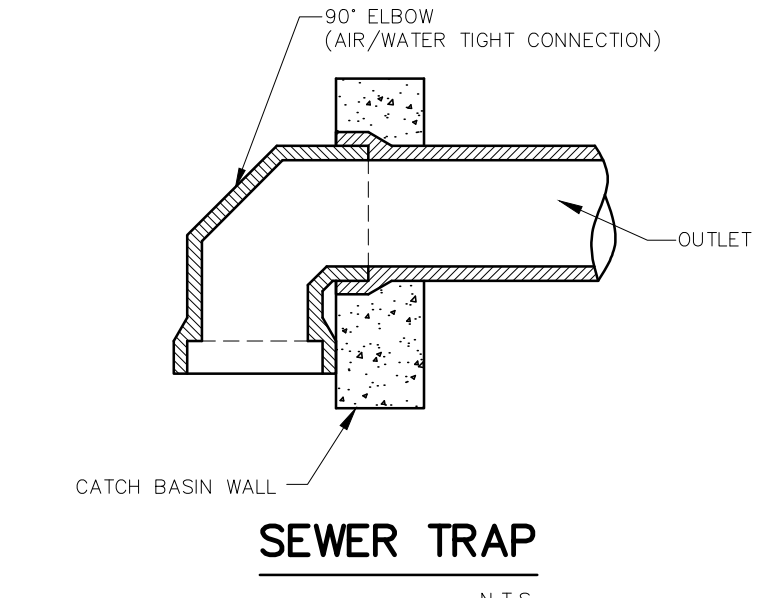

**EX. COMB. SEWER STRUCTURE SCHEDULE**

03 MANTAIN 0+40.98' 32.98' L MH 03 RIM 770.09 24" SW. INV. 759.32(R) 30" SE. INV. 758.69(R) 18" NE. INV. 758.74(R) 15" NW. INV. 759.79(R) 12" E. INV. 765.41(R)	03A MANTAIN 0+44.76' 51.07' R STORM MH 03A RIM 769.74 30" SE. INV. 758.33(R) 30" NW. INV. 758.44(R)
07A MANTAIN 0+34.27' 37.23' L MH 7A RIM 769.58 24" NW. INV. 759.00(R) 24" NE. INV. 758.90(R) 18" SE. INV. 758.65(R) 12" NW. INV. 764.30(R) 12" W. INV. 764.50(R)	14b MANTAIN 0+29.82' 2.93' R COMB. MH 14b RIM 769.67 18" SE. 764.40(R)/BRAKHEAD 18" NW. 758.56(R) 18" SW. 759.29(R)
127 ADJUST 1+58.10' 12.75' L COMB. MH 127 RIM 770.42 PR. RIM 770.83 18" SE. INV. 759.07(R) 18" SW. INV. 759.07(R) 12" W. INV. 760.92(R)	126 ADJUST 2+01.06' 4.44' L COMB. MH 126 RIM 771.03 PR. RIM 770.98 18" NE. INV. 759.35(R) 18" SW. INV. 759.29(R)
07B MANTAIN 0+43.07' 52.53' L MH 07B RIM 769.40	128 MANTAIN 1+69.76' 70.71' L MH 128 RIM 770.26
06 ADJUST 0+91.96' 35.40' L COMB. MH 06 RIM 770.53 PR. RIM 770.43	19 MANTAIN 0+45.96' 48.72' L HYD. BR. F.C. 769.77
07 ADJUST 0+87.75' 24.83' R COMB. MH 07 RIM 770.29 PR. RIM 769.95	20 MANTAIN 0+34.49' 45.00' R COMB. MH 20 RIM 769.55

**EX. WATER MAIN SCHEDULE**

06 ADJUST 0+91.96' 35.40' L COMB. MH 06 RIM 770.53 PR. RIM 770.43	19 MANTAIN 0+45.96' 48.72' L HYD. BR. F.C. 769.77
07 ADJUST 0+87.75' 24.83' R COMB. MH 07 RIM 770.29 PR. RIM 769.95	20 MANTAIN 0+34.49' 45.00' R COMB. MH 20 RIM 769.55

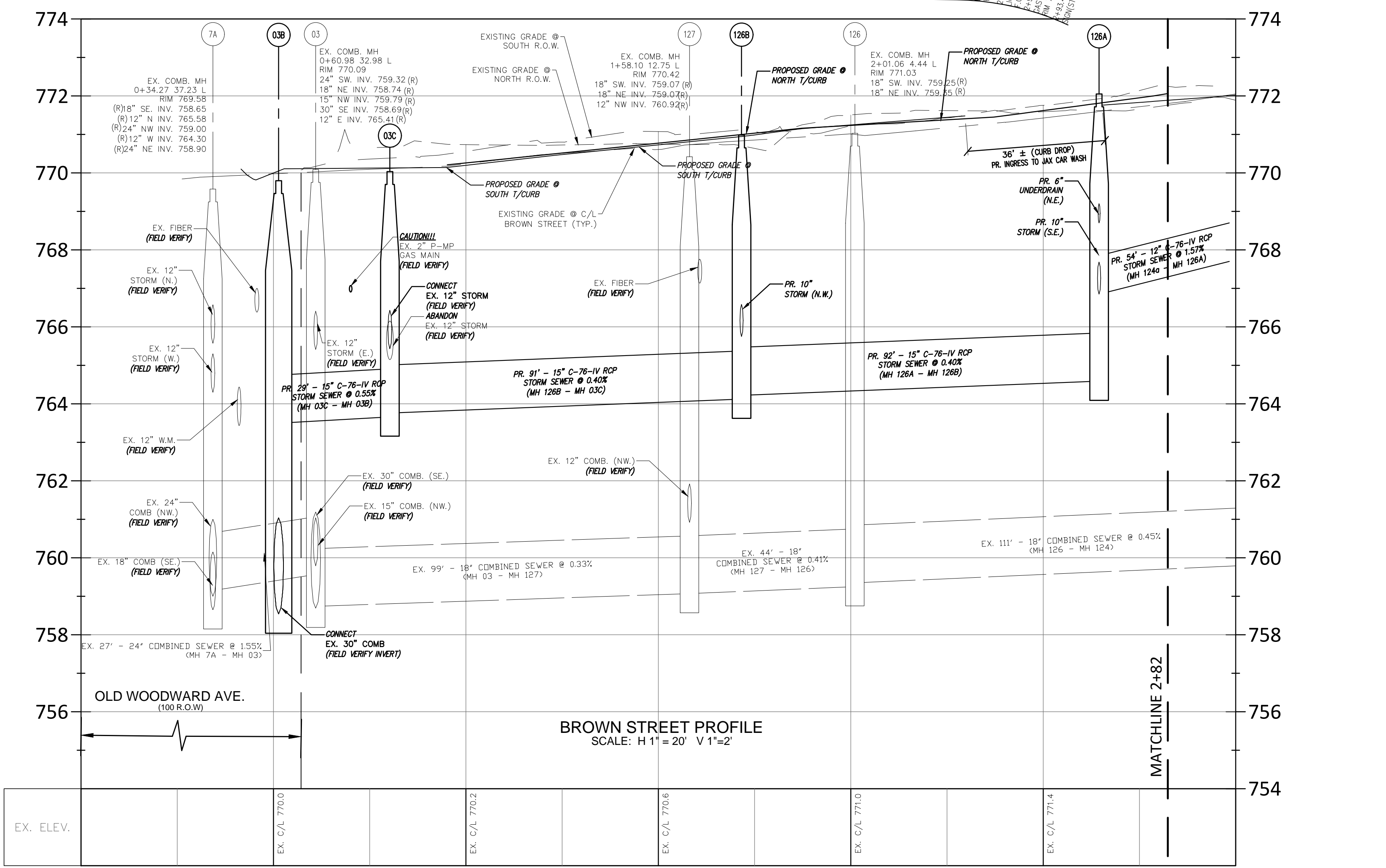

**NOTE:**  
 TRAFFIC STORAGE AND PAVEMENT MARKING ADJUSTMENTS REQUIRED FOR EAST-BOUND BROWN STREET TO REQUIRE RIGHT LANE TURNS RIGHT AT OLD WOODWARD (NO THRU TRAFFIC FOR SOUTHERLY TRAVEL LANE ACROSS OLD WOODWARD).

**LIGHT POLE REMOVAL NOTE:**  
 ALL LIGHT POLES TO BE REMOVED BY DUE. (CONTRACTOR TO REMOVE FOOTING)

**CAUTION!!**  
 EX. 2" GAS MAIN

**CAUTION!!**  
 EX. 2" GAS MAIN

SEAL

PROJECT  
 Brown Street Paving Project  
 Contract # 5-23(P)

CLIENT



Engineering Department  
 151 Martin Street  
 Birmingham, MI 48012

PROJECT LOCATION  
 Part of the Northeast 1/4  
 of Section 36  
 Town 2 North,  
 Range 10 East  
 City of Birmingham,  
 Oakland County, Michigan

SHEET

Utility Plan (2 of 2)  
 Sta. 2+82 to P.O.E.



DATE ISSUED/REVISED  
 12-08-22 ISSUED SURVEY  
 02-04-23 CONCEPT PLAN  
 02-14-23 UPDATED CONCEPT PLAN  
 03-16-23 90% CITY REVIEW  
 04-10-23 RIDS  
 04-26-23 ADDENDUM 1

DRAWN BY:  
 G. Viju  
 DESIGNED BY:  
 G. Viju  
 APPROVED BY:  
 B. Buchholz

DATE:  
 March 16, 2023

SCALE: 1" = 20'

NFE JOB NO. SHEET NO.  
**D162-01 C2**

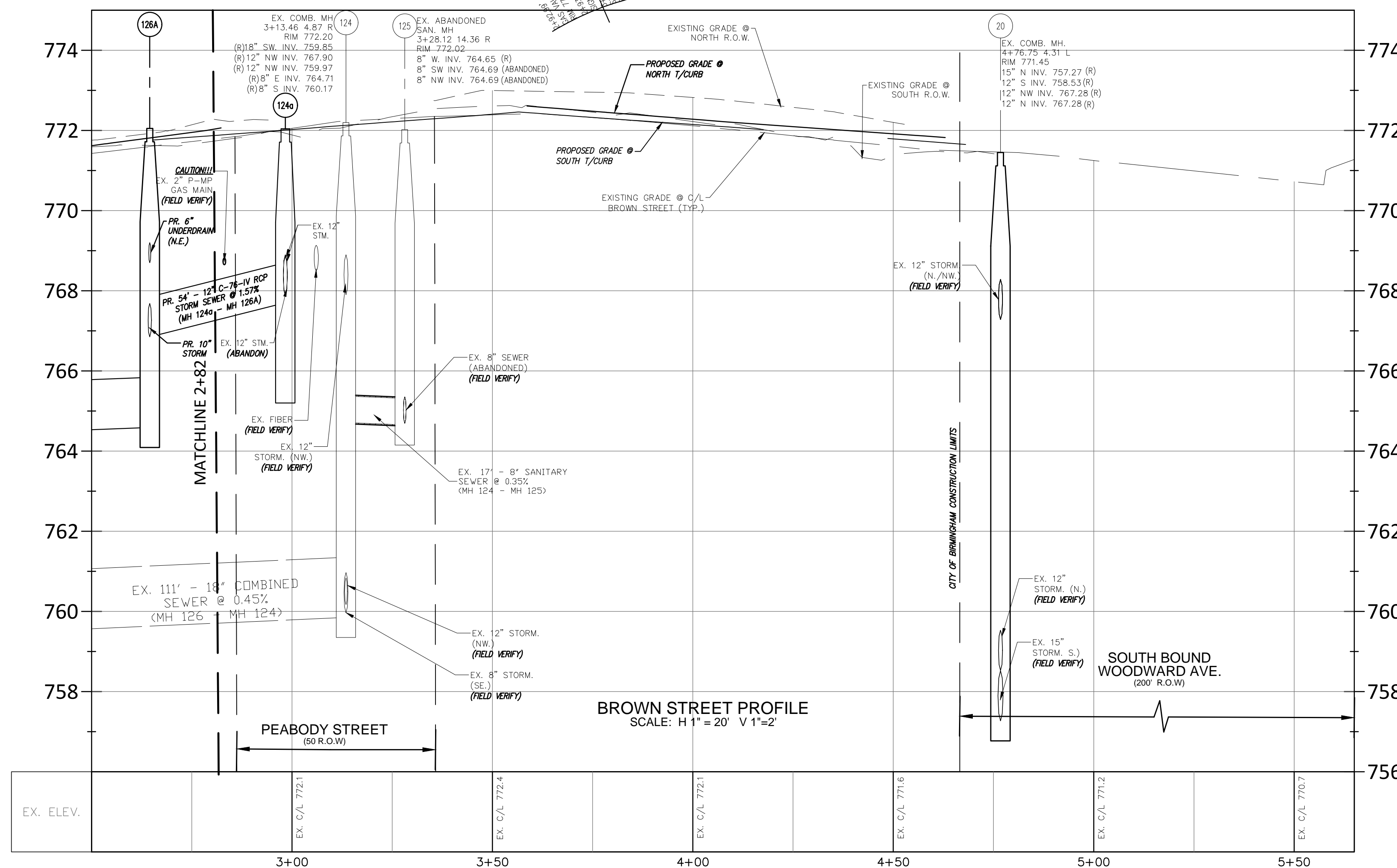
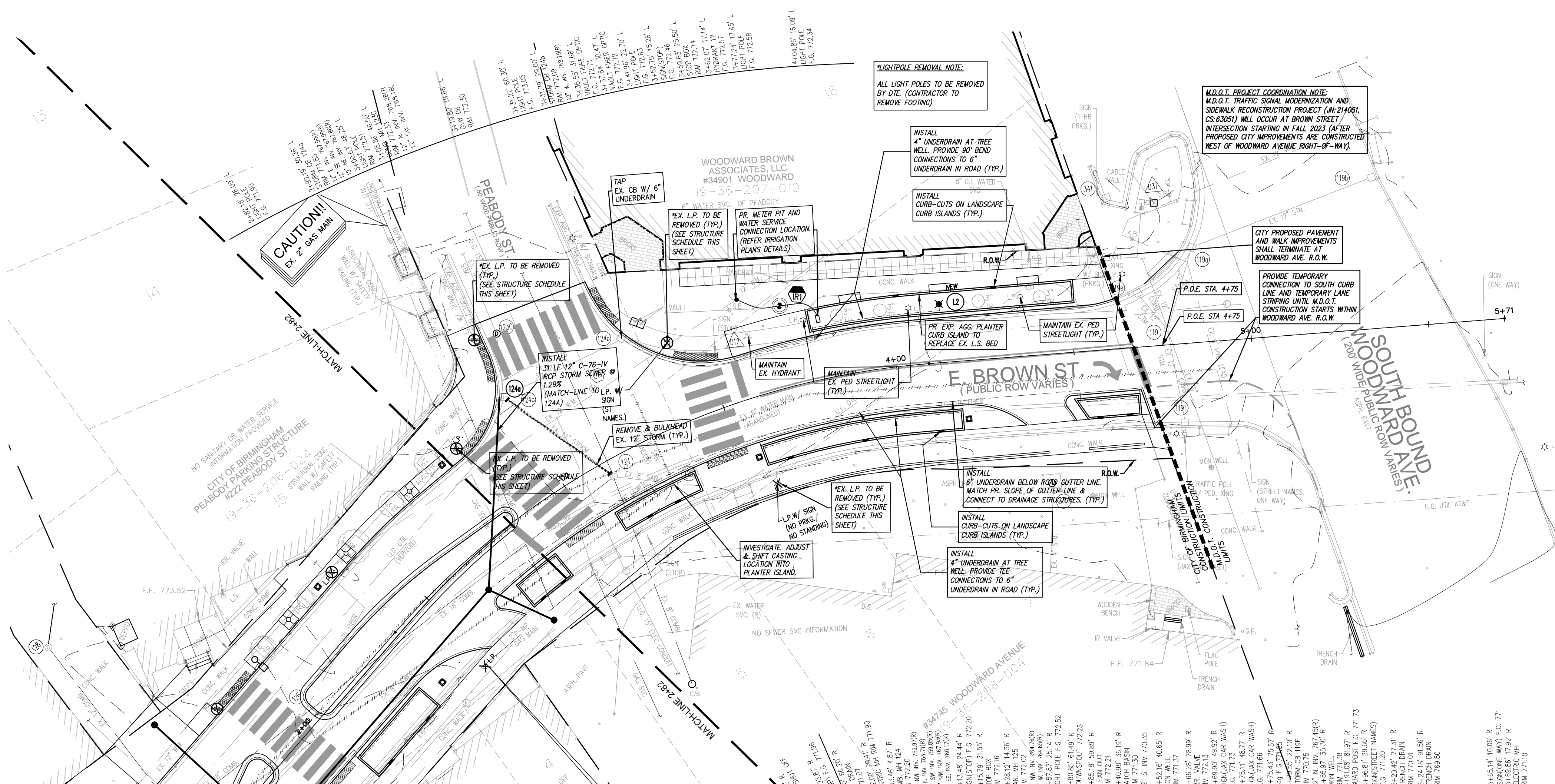

**EX. COMB. SEWER STRUCTURE SCHEDULE**

124	BULKHEAD & ADJUST 3+13.46' 4.87' R COMB. MH 124 PR. RIM 772.20	125	INVESTIGATE, ADJUST, & SHFT CASTING LOCATION INTO PLANTER ISLAND 3+28.12' 14.30' R SAN. MH 125 PR. RIM 772.02
123C	ADJUST 3+52.96' 46.50' L COMB. MH 123C PR. RIM 772.53		
119	MANTAIN 4+76.75' 4.31' L COMB. MH 119 PR. RIM 771.45		

**EX. STORM STRUCTURE SCHEDULE**

119a	MANTAIN 4+55.29' 26.80' L STORM CB 119a PR. RIM 771.25	119b	MANTAIN 5+31.95' 42.46' L STORM CB 119b PR. RIM 771.53
119c	MANTAIN 4+69.14' 15.20' L STORM CB 119c PR. RIM 771.26	119f	MANTAIN 4+79.55' 22.10' R STORM CB 119f PR. RIM 770.75
124a	TAP, BULKHEAD INVESTIGATE, ADJUST & SHFT CASTING INTO CURB LINE 2+59.19' 30.36' L STORM CB 124a PR. RIM 771.83	124b	TAP +31.79' 29.00' L STORM CB 124b PR. RIM 772.09
CB	MANTAIN 4+40.98' 36.19' R CATCH BASIN PR. RIM 771.30	341	MANTAIN 4+62.52' 42.55' L STORM CB 341 PR. RIM 771.79

**EX. WATER MAIN SCHEDULE**

OB	MANTAIN 3+19.80' 19.66' L G.W. OB PR. RIM 772.30	MAINTAIN	3+62.07' 17.14' L HYDRANT 12 F.G. 772.57
BT	INSTALL STA 3+72.16 22.85 L IRRIGATION METER PIT ASSEMBLY W/ 1.5" WATER SERVICE (PER DETAIL AND IRRIGATION PLANS) PR. RIM 768.16		

**WATER SERVICE SCHEDULE**

STATION	ADDRESS/DESC.	EX. W.M.	SIC. DIA.	SIC. MATERIAL	LENGTH	NEW CURB SOFT
03+72.16 22.85	NEW METER PIT	12"	1.5"	COPPER	25 LF.	N.

**EX. STREET LIGHT REMOVAL SCHEDULE**

E. BROWN STREET, P.O.B. TO +2+82		
STATION	OFFSET	ITEM
STA. 2+82.19	26.08' L.	PEDESTRIAN STREET LIGHT
STA. 3+00.63	48.24' L.	PEDESTRIAN STREET LIGHT
STA. 3+42.07	22.67' L.	PEDESTRIAN STREET LIGHT
SOUTH		
STA. 3+57.87	25.14' R.	COBRA HEAD LIGHT POLE

**UTILITY NOTE**

THE LOCATIONS AND ELEVATIONS OF SOME OF THE EXISTING UNDERGROUND UTILITIES AS SHOWN ON THE SURVEY DRAWING WERE OBTAINED FROM MUNICIPAL AND UTILITY COMPANY RECORDS AND MAPS. THEREFORE, NO GUARANTEE IS EITHER EXPRESSED OR IMPLIED AS TO THE COMPLETENESS OR ACCURACY THEREOF. THE CONTRACTOR SHALL BE RESPONSIBLE FOR DETERMINING THE EXACT UTILITY LOCATIONS AND ELEVATIONS PRIOR TO THE START OF CONSTRUCTION.

**Pr. Storm Sewer Structure Schedule**

Structure Name	Structure Details
#L2 PR. 12" DIA. LANDSCAPE DRAIN W/ CAST-IRON BEE-HIVE COVER	PR. RIM 772.36 PR. 4" S. INV. 768.01

**L.P. REMOVAL LEGEND**

X	EX. COBRA HEAD LIGHT POLE REMOVAL
⊗	EXISTING PEDESTRIAN STREET LIGHT REMOVAL

**LEGEND**

MANHOLE	EXISTING SANITARY SEWER
HYDRANT	SAN. CLEAN OUT
MANHOLE	EXISTING WATERMAIN
MANHOLE	EXISTING STORM SEWER
MANHOLE	EX. R. Y. CATCH BASIN
UTILITY POLE	EXISTING BURIED CABLES
GUY WIRE	OVERHEAD LINES
GUY WIRE	LIGHT POLE
SIGN	SIGN
MANHOLE	EXISTING GAS MAIN
MANHOLE	PR. SANITARY SEWER
MANHOLE	PR. WATER MAIN
MANHOLE	PR. STORM SEWER
MANHOLE	PR. R. Y. CATCH BASIN
PROPOSED TREE GRATE	PROPOSED TREE GRATE



SEAL

PROJECT  
Brown Street Paving Project  
Contract # 5-23(P)

CLIENT



Engineering Department  
151 Martin Street  
Birmingham, MI 48012

PROJECT LOCATION

Part of the Northeast 1/4  
of Section 36  
Town 2 North,  
Range 10 East  
City of Birmingham,  
Oakland County, Michigan

SHEET

Storm Profile Plan



Know what's below  
Call before you dig.

DATE ISSUED/REVISED

12-08-22 ISSUED SURVEY  
02-04-23 CONCEPT PLAN  
02-14-23 UPDATED CONCEPT PLAN  
03-16-23 90% CITY REVIEW  
04-10-23 BIDS  
04-26-23 ADDENDUM 1

DRAWN BY:

G. Viju

DESIGNED BY:

G. Viju

APPROVED BY:

B. Buchholz

DATE:

March 16, 2023

SCALE: 1" = 20'

20 10 0 10 20 30

NFE JOB NO. SHEET NO.

D162-01 C3

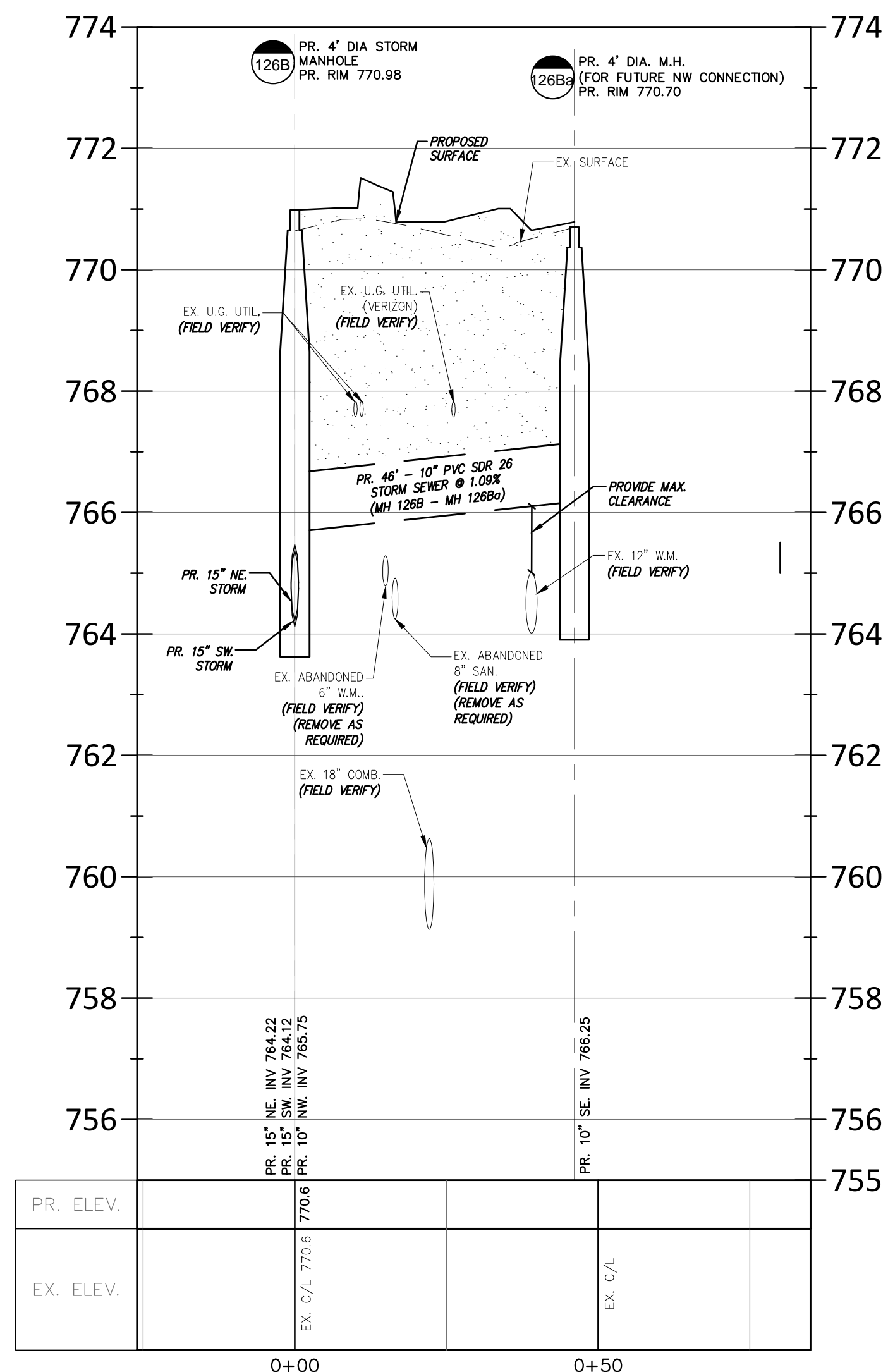

STORM PROFILE (MH 126B-MH 126Ba)

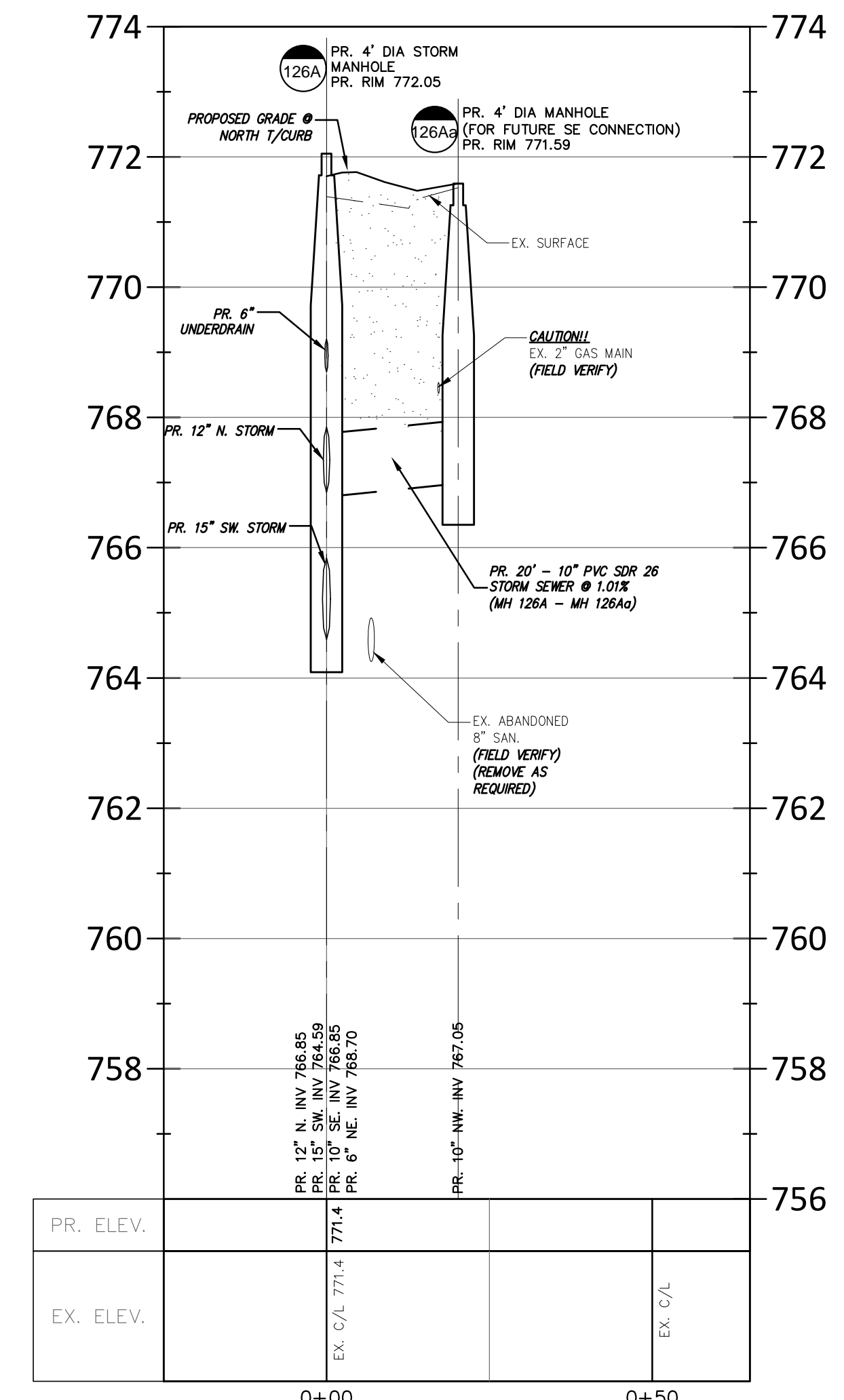

STORM PROFILE (MH 126A-MH 126Aa)

SEAL

PROJECT  
Brown Street Paving Project  
Contract # 5-23(P)



Engineering Department  
151 Martin Street  
Birmingham, MI 48012

PROJECT LOCATION  
Part of the Northeast 1/4  
of Section 36  
Town 2 North,  
Range 10 East  
City of Birmingham,  
Oakland County, Michigan

SHEET  
Grading Plan (1 of 2)



Know what's below  
Call before you dig.

DATE	ISSUED/REVISED
12-08-22	ISSUED SURVEY
02-04-23	CONCEPT PLAN
02-14-23	UPDATED CONCEPT PLAN
03-16-23	90% CITY REVIEW
04-10-23	RIDS
04-26-23	ADDENDUM 1

DRAWN BY:  
G. Viju

DESIGNED BY:  
G. Viju

APPROVED BY:  
B. Buchholz

DATE:  
March 16, 2023

SCALE: 1" = 20'

NFE JOB NO. SHEET NO.  
D162-01 C4

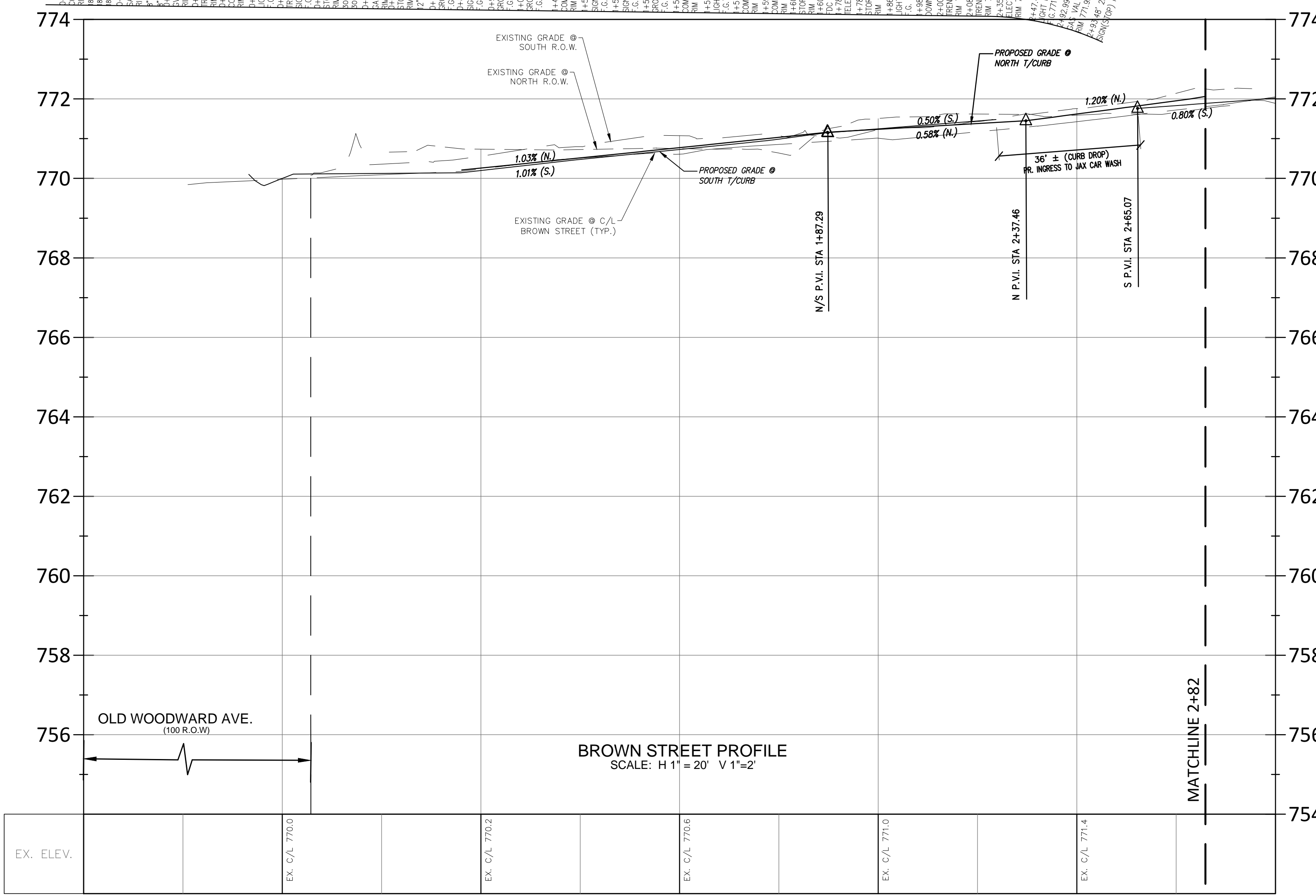
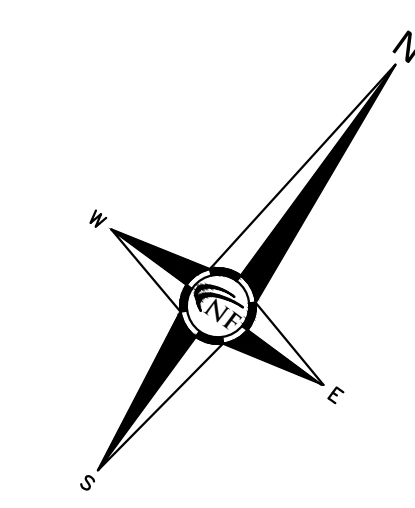
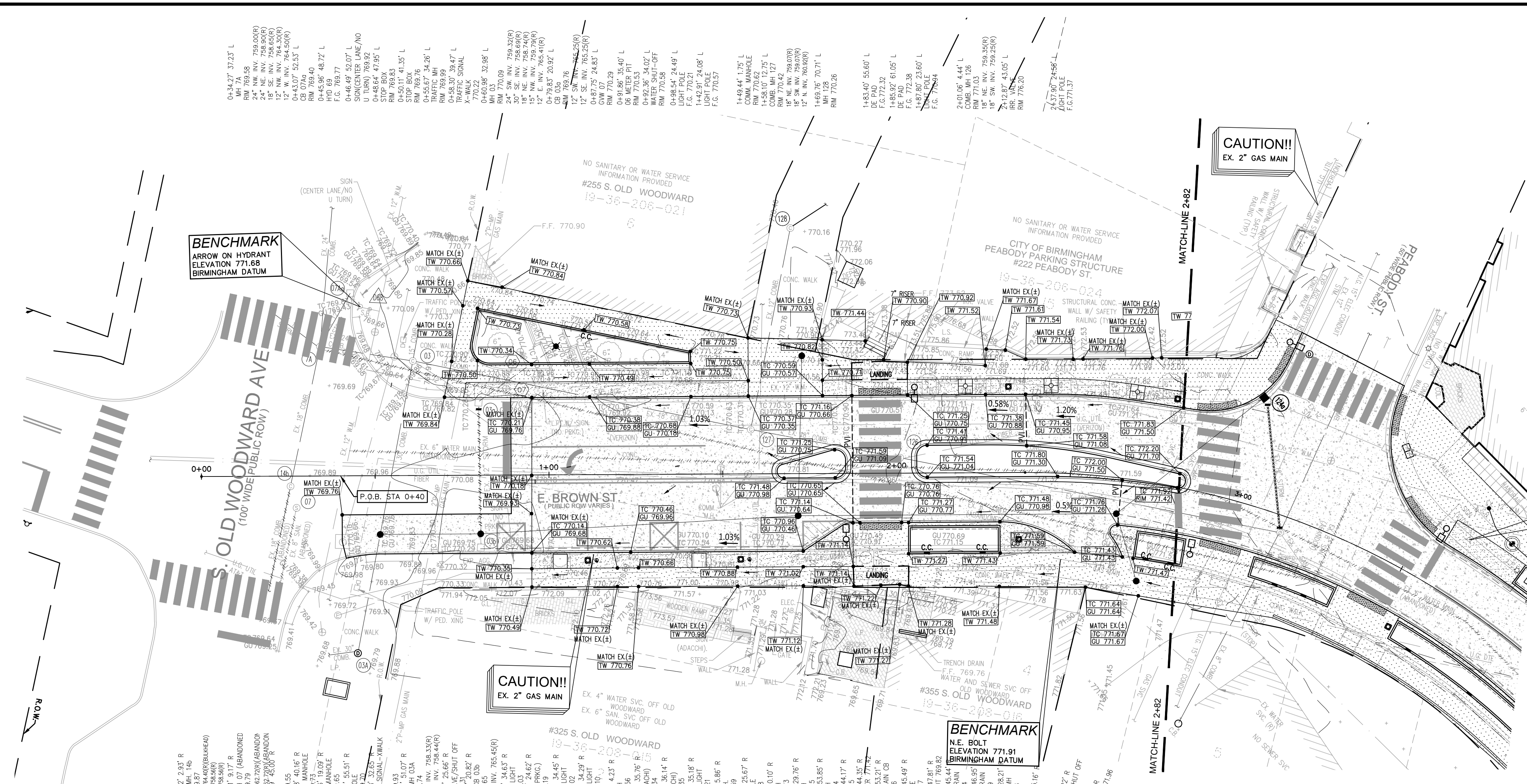

**PAVING LEGEND**

[Pattern]	PROPOSED 4" EXPOSED AGGREGATE SIDEWALK
[Pattern]	PROPOSED 4" STANDARD SIDEWALK W/ SAWCUT PATTERN
[Pattern]	PROPOSED 8" CONCRETE PAVEMENT W/ INT. CURB
[Pattern]	PROPOSED ASPHALT PAVEMENT
[Pattern]	PROPOSED WALK BOX-OUT FOR TREE/MULCH
C.C.	PROPOSED CURB CUTS ON LANDSCAPE CURB ISLANDS

**LEGEND**

[Symbol]	MANHOLE	EXISTING SANITARY SEWER
[Symbol]	HYDRANT	SAN. CLEAN OUT
[Symbol]	MANHOLE CATCH BASIN	EXISTING WATERMAIN
[Symbol]	UTILITY POLE	EXISTING STORM SEWER
[Symbol]	GUY POLE	EX. R. Y. CATCH BASIN
[Symbol]	GUY WIRE	EXISTING BURIED CABLES
[Symbol]	C.O.	OVERHEAD LINES
[Symbol]	HYDRANT	LIGHT POLE
[Symbol]	INLET	SIGN
[Symbol]	MANHOLE	EXISTING GAS MAIN
[Symbol]	GATE VALVE	PR. SANITARY SEWER
[Symbol]	C.B.	PR. WATER MAIN
[Symbol]	MANHOLE	PR. STORM SEWER
[Symbol]		PR. R. Y. CATCH BASIN
[Symbol]		PROPOSED LIGHT POLE
[Symbol]		PROPOSED TREE GRATE
[Symbol]		PR. INTERSECTION LIGHT POLE
[Symbol]		PR. PEDESTRIAN LIGHT POLE
[Symbol]		PR. PARKING METER
[Symbol]		PR. TOP OF CURB ELEV.
[Symbol]		PR. GUTTER ELEVATION
[Symbol]		PR. TOP OF WALK ELEV.
[Symbol]		PR. TOP OF PAVT. ELEV.
[Symbol]		PR. RIM ELEV.

SEAL

PROJECT  
**Brown Street Paving Project**  
Contract # 5-23(P)

CLIENT



Engineering Department  
151 Martin Street  
Birmingham, MI 48012

PROJECT LOCATION  
Part of the Northeast 1/4  
of Section 36  
Town 2 North,  
Range 10 East  
City of Birmingham,  
Oakland County, Michigan

SHEET  
Grading Plan (2 of 2)



Know what's below  
Call before you dig.

DATE	ISSUED/REVISED
12-08-22	ISSUED SURVEY
02-04-23	CONCEPT PLAN
02-14-23	UPDATED CONCEPT PLAN
03-16-23	90% CITY REVIEW
04-10-23	BIDS
04-26-23	ADDENDUM 1

DRAWN BY:  
G. Viju

DESIGNED BY:  
G. Viju

APPROVED BY:  
B. Buchholz

DATE:  
March 16, 2023

SCALE: 1" = 20'

NFE JOB NO. SHEET NO.

**D162-01**

**C5**

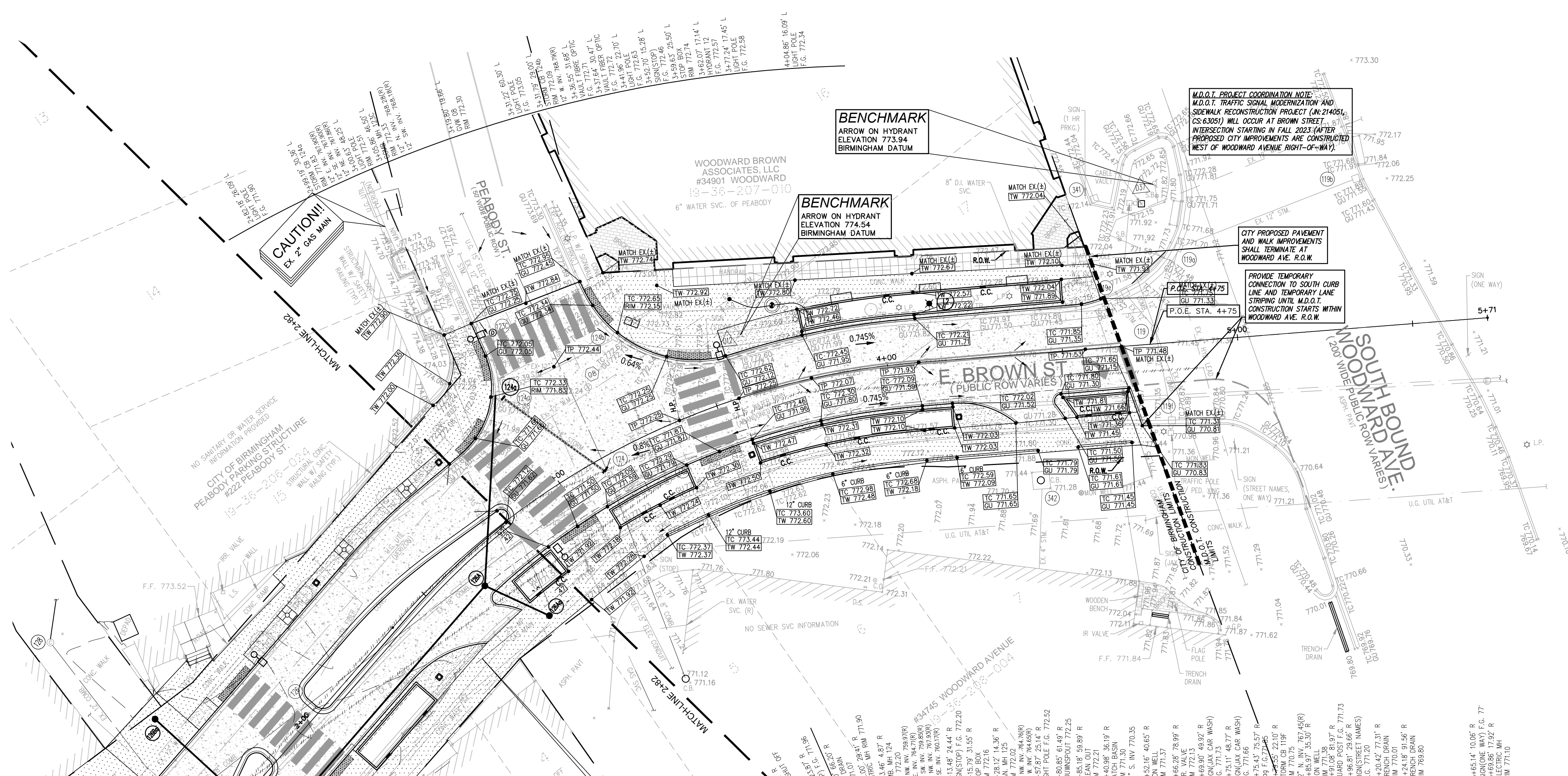

PAVING LEGEND	
[Pattern]	PROPOSED 4" EXPOSED AGGREGATE SIDEWALK
[Pattern]	PROPOSED 4" STANDARD SIDEWALK W/ SAWCUT PATTERN
[Pattern]	PROPOSED 8" CONCRETE PAVEMENT W/ INT. CURB
[Pattern]	PROPOSED ASPHALT PAVEMENT
[Pattern]	PROPOSED WALK BOX-OUT FOR TREE/MULCH
C.C.	PROPOSED CURB CUTS ON LANDSCAPE CURB ISLANDS

LEGEND	
[Symbol]	MANHOLE
[Symbol]	EXISTING SANITARY SEWER
[Symbol]	HYDRANT
[Symbol]	SAN. CLEAN OUT
[Symbol]	EXISTING WATERMAIN
[Symbol]	MANHOLE CATCH BASIN
[Symbol]	EXISTING STORM SEWER
[Symbol]	EX. R. Y. CATCH BASIN
[Symbol]	EXISTING BURIED CABLES
[Symbol]	UTILITY POLE
[Symbol]	GUY WIRE
[Symbol]	GUY POLE
[Symbol]	OVERHEAD LINES
[Symbol]	LIGHT POLE
[Symbol]	SIGN
[Symbol]	EXISTING GAS MAIN
[Symbol]	C.O. MANHOLE
[Symbol]	PR. SANITARY SEWER
[Symbol]	HYDRANT
[Symbol]	GATE VALVE
[Symbol]	PR. WATER MAIN
[Symbol]	INLET
[Symbol]	C.B. MANHOLE
[Symbol]	PR. STORM SEWER
[Symbol]	PR. R. Y. CATCH BASIN
[Symbol]	PROPOSED LIGHT POLE
[Symbol]	PROPOSED TREE GRATE
[Symbol]	PR. INTERSECTION LIGHT POLE
[Symbol]	PR. PEDESTRIAN LIGHT POLE
[Symbol]	PR. PARKING METER
[Symbol]	PR. TOP OF CURB ELEV.
[Symbol]	PR. GUTTER ELEVATION
[Symbol]	PR. TOP OF WALK ELEV.
[Symbol]	PR. TOP OF PAVT. ELEV.
[Symbol]	PR. RM ELEV.

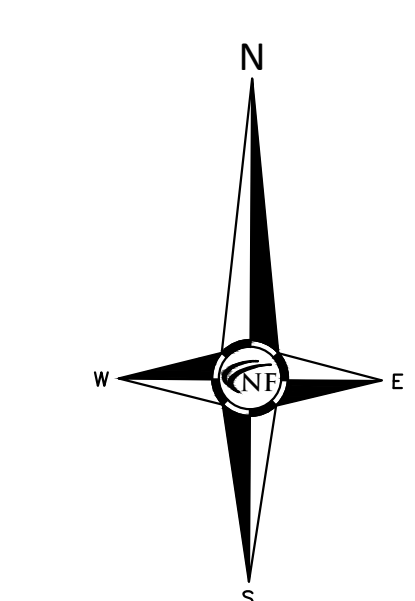
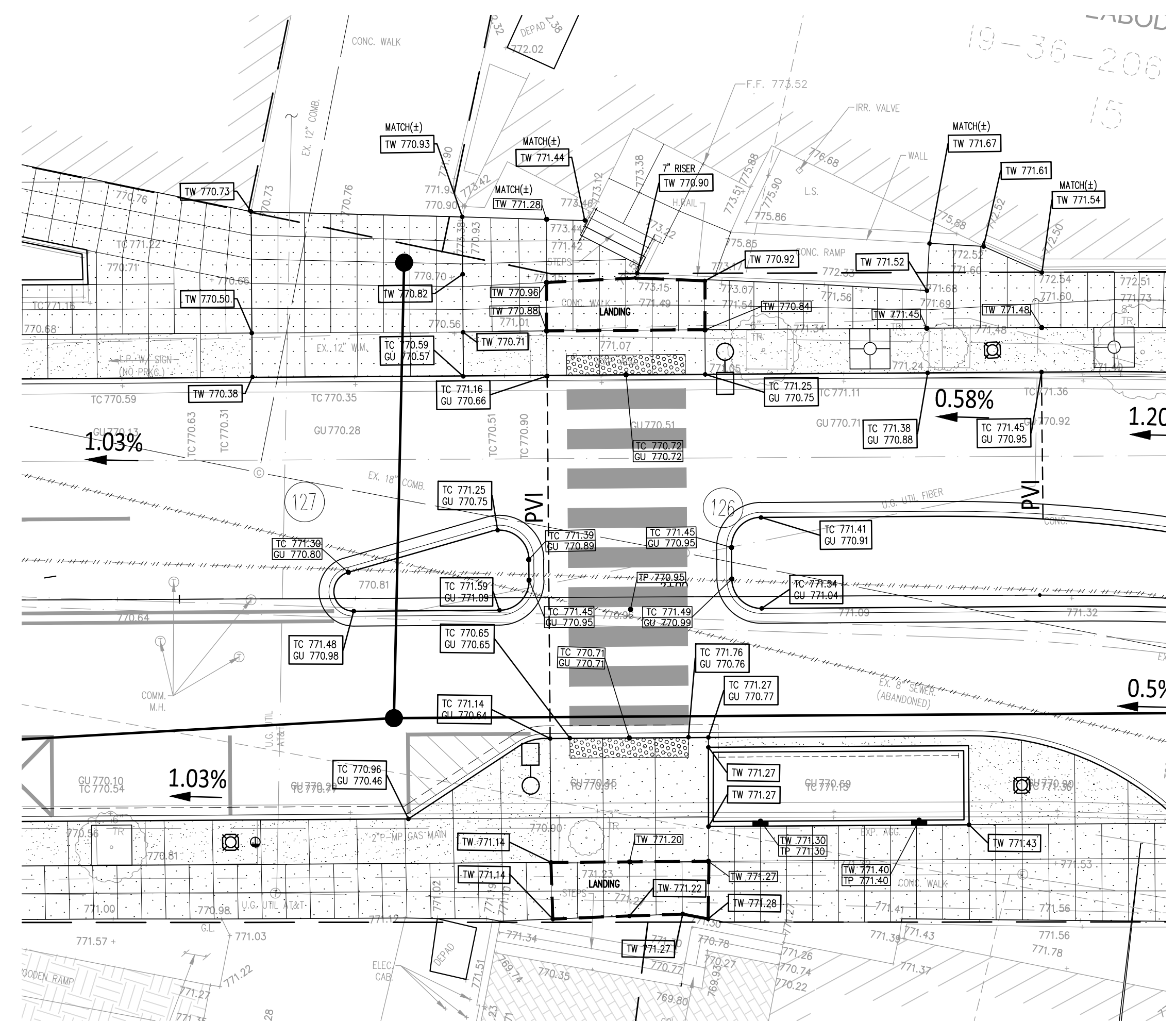
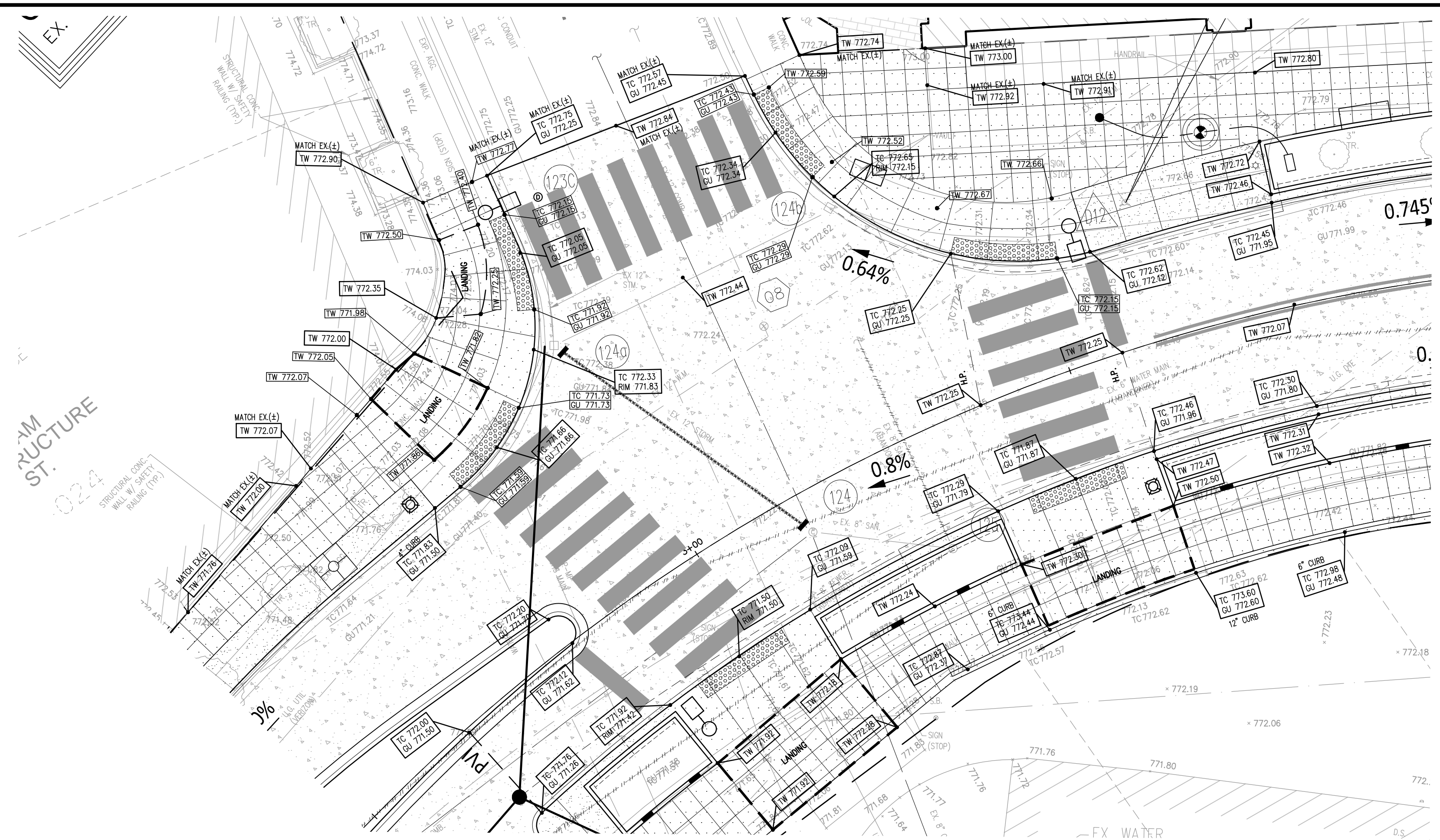

**PAVING LEGEND**

	PROPOSED 4" EXPOSED AGGREGATE SIDEWALK
	PROPOSED 4" STANDARD SIDEWALK W/ SAWCUT PATTERN
	PROPOSED 8" CONCRETE PAVEMENT W/ INT. CURB
	PROPOSED ASPHALT PAVEMENT
	PROPOSED WALK BOX-OUT FOR TREE/MULCH
	C.C. PROPOSED CURB CUTS ON LANDSCAPE CURB ISLANDS

**LEGEND**

	MANHOLE		EXISTING SANITARY SEWER
	HYDRANT		SAN. CLEAN OUT
	GATE VALVE		EXISTING WATERMAIN
	MANHOLE CATCH BASIN		EXISTING STORM SEWER
	UTILITY POLE		EX. R. Y. CATCH BASIN
	GUY POLE		EXISTING BURIED CABLES
	GUY WIRE		OVERHEAD LINES
	LIGHT POLE		SIGN
	C.O. MANHOLE		EXISTING GAS MAIN
	HYDRANT		PR. SANITARY SEWER
	INLET		PR. WATER MAIN
	C.B. MANHOLE		PR. STORM SEWER
	PR. R. Y. CATCH BASIN		PROPOSED LIGHT POLE
	PR. INTERSECTION LIGHT POLE		PROPOSED TREE GRATE
	PR. PEDESTRIAN LIGHT POLE		PR. PARKING METER
	PR. TOP OF CURB ELEV.		PR. TOP OF WALK ELEV.
	PR. TOP OF GUTTER ELEV.		PR. TOP OF P.W.T. ELEV.
	PR. TOP OF P.W.T. ELEV.		PR. RIM ELEV.

**NF ENGINEERS**  
 CIVIL ENGINEERS  
 LAND SURVEYORS  
 LAND PLANNERS

NOWAK & FRAUS ENGINEERS  
 46777 WOODWARD AVE.  
 PONTIAC, MI 48342-5032  
 TEL. (248) 332-7931  
 FAX. (248) 332-8257  
 WWW.NFE-ENGR.COM

SEAL

PROJECT  
 Brown Street Paving Project  
 Contract # 5-23(P)

CLIENT

**BIRMINGHAM**  
 A WALKABLE CITY

Engineering Department  
 151 Martin Street  
 Birmingham, MI 48012

PROJECT LOCATION  
 Part of the Northeast 1/4  
 of Section 36  
 Town 2 North,  
 Range 10 East  
 City of Birmingham,  
 Oakland County, Michigan

SHEET  
 Intersection Grading  
 Detail (1 of 2)

**811**  
 Know what's below  
 Call before you dig.

DATE	ISSUED/REVISED
12-08-22	ISSUED SURVEY
02-04-23	CONCEPT PLAN
02-14-23	UPDATED CONCEPT PLAN
03-16-23	90% CITY REVIEW
04-10-23	BIDS
04-26-23	ADDENDUM 1

DRAWN BY:  
 G. Viju

DESIGNED BY:  
 G. Viju

APPROVED BY:  
 B. Buchholz

DATE:  
 March 16, 2023

SCALE: 1" = 20'

NFE JOB NO. SHEET NO.  
**D162-01 C6**

SEAL

PROJECT  
Brown Street Paving Project  
Contract # 5-23(P)



Engineering Department  
151 Martin Street  
Birmingham, MI 48012

PROJECT LOCATION  
Part of the Northeast 1/4  
of Section 36  
Town 2 North,  
Range 10 East  
City of Birmingham,  
Oakland County, Michigan

SHEET  
Intersection Grading  
Detail Plan  
(2 of 2)



Know what's below  
Call before you dig.

DATE	ISSUED/REVISED
12-08-22	ISSUED SURVEY
02-04-23	CONCEPT PLAN
02-14-23	UPDATED CONCEPT PLAN
03-16-23	90% CITY REVIEW
04-10-23	RIDS
04-26-23	ADDENDUM 1

DRAWN BY:  
G. Viju

DESIGNED BY:  
G. Viju

APPROVED BY:  
B. Buchholz

DATE:  
March 16, 2023

SCALE: 1" = 20'

NFE JOB NO. SHEET NO.

D162-01 C7

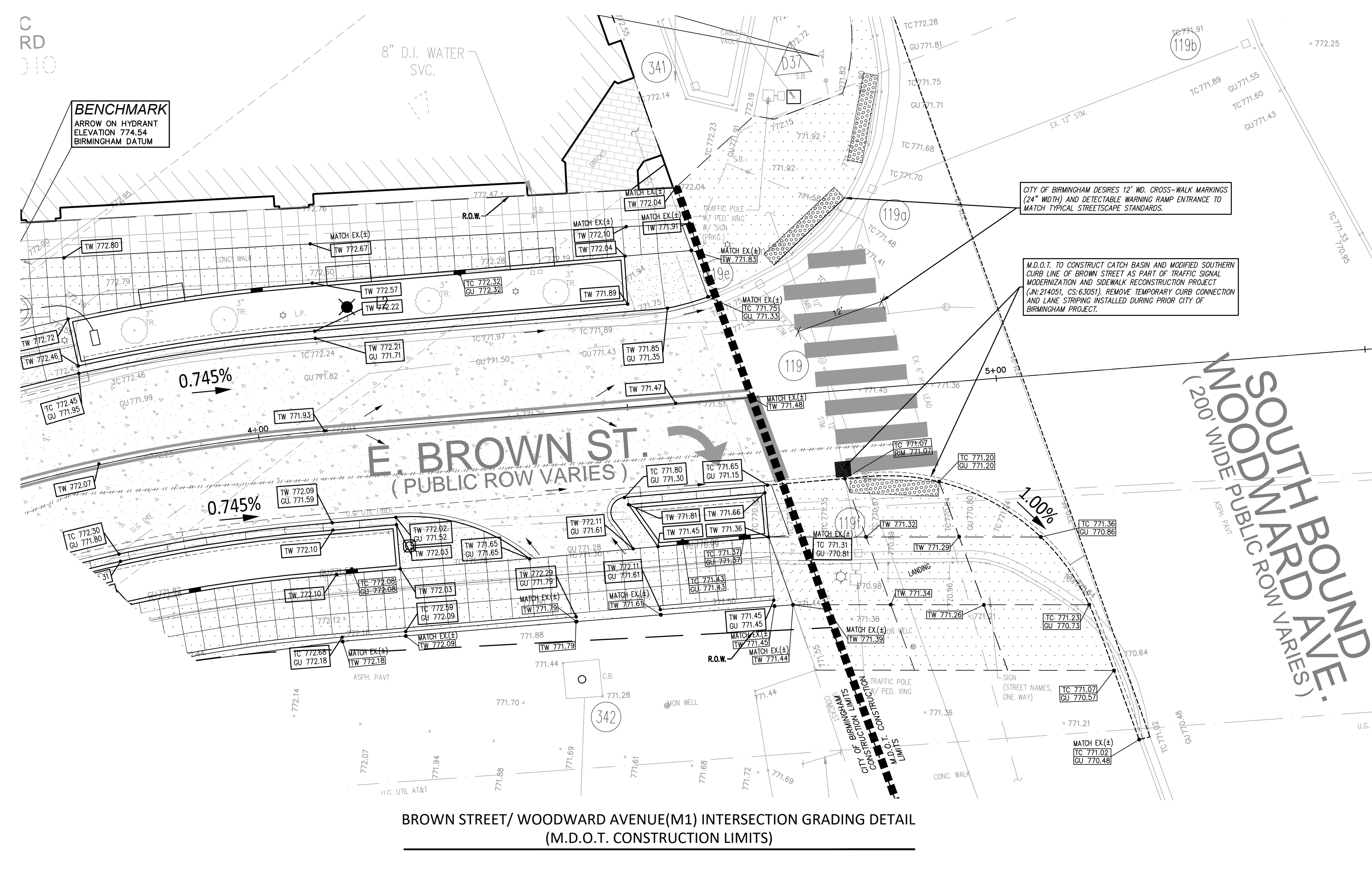
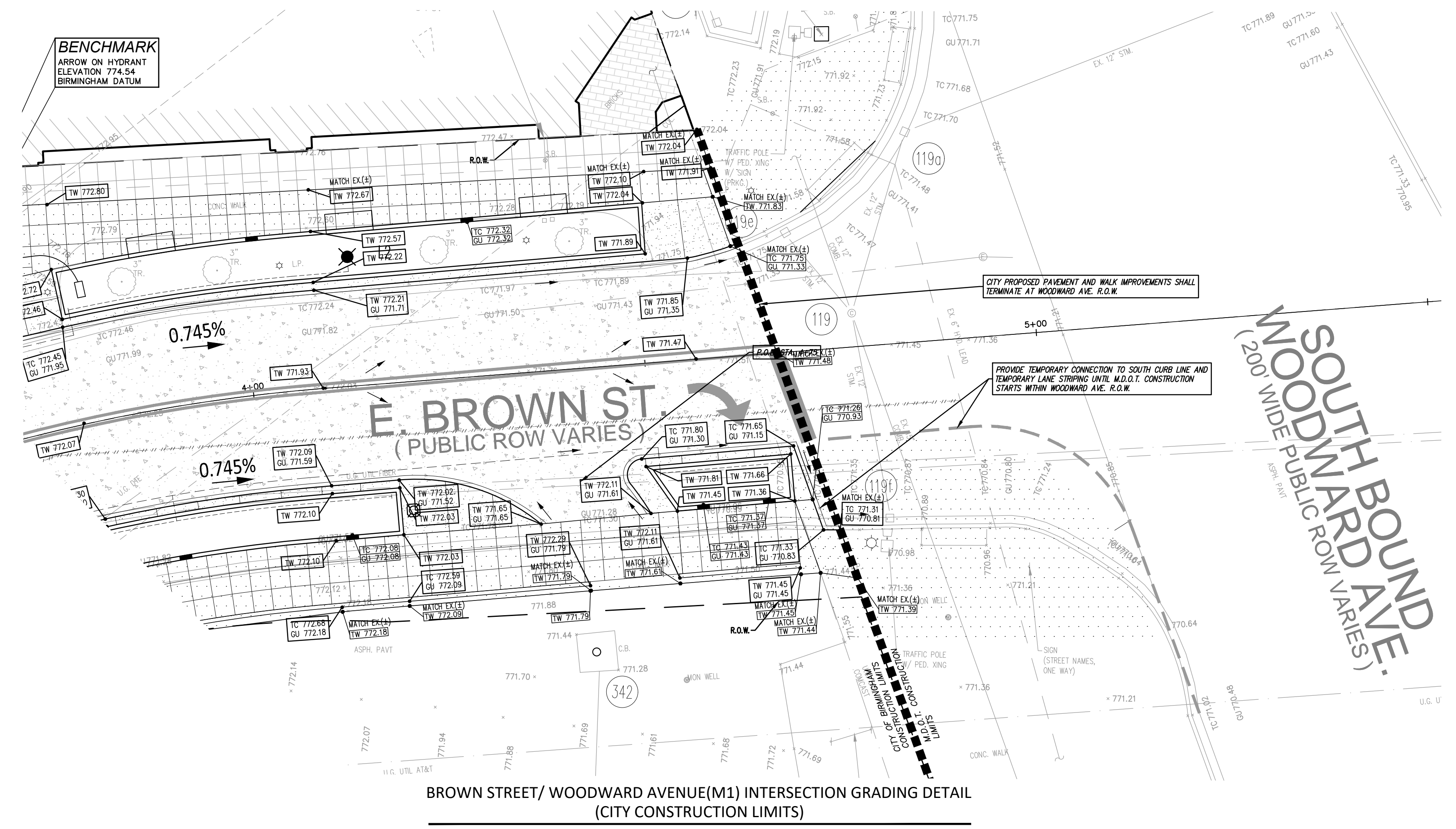

**PAVING LEGEND**

[Pattern]	PROPOSED 4" EXPOSED AGGREGATE SIDEWALK
[Pattern]	PROPOSED 4" STANDARD SIDEWALK W/ SAWCUT PATTERN
[Pattern]	PROPOSED 8" CONCRETE PAVEMENT W/ INT. CURB
[Pattern]	PROPOSED ASPHALT PAVEMENT
[Pattern]	PROPOSED WALK BOX-OUT FOR TREE/MULCH
C.C.	PROPOSED CURB CUTS ON LANDSCAPE CURB ISLANDS

**LEGEND**

[Symbol]	MANHOLE	EXISTING SANITARY SEWER
[Symbol]	HYDRANT	SAN. CLEAN OUT
[Symbol]	GATE VALVE	EXISTING WATERMAIN
[Symbol]	MANHOLE	EXISTING STORM SEWER
[Symbol]	CATCH BASIN	EX. R. Y. CATCH BASIN
[Symbol]	UTILITY POLE	EXISTING BURIED CABLES
[Symbol]	GUY POLE	OVERHEAD LINES
[Symbol]	GUY WIRE	LIGHT POLE
[Symbol]	SIGN	EXISTING GAS MAIN
[Symbol]	C.O.	PR. SANITARY SEWER
[Symbol]	MANHOLE	PR. WATER MAIN
[Symbol]	GATE VALVE	PR. STORM SEWER
[Symbol]	INLET	PR. R. Y. CATCH BASIN
[Symbol]	MANHOLE	PROPOSED LIGHT POLE
[Symbol]		PROPOSED TREE GRATE
[Symbol]		PR. INTERSECTION LIGHT POLE
[Symbol]		PR. PEDESTRIAN LIGHT POLE
[Symbol]		PR. PARKING METER
[Symbol]	TC 700.00	PR. TOP OF CURB ELEV.
[Symbol]	GU 700.00	PR. GUTTER ELEVATION
[Symbol]	TW 700.00	PR. TOP OF WALK ELEV.
[Symbol]	TP 700.00	PR. TOP OF P.W.M. ELEV.
[Symbol]	RIM 700.00	PR. RIM ELEV.

SEAL

PROJECT  
Brown Street Paving Project  
Contract # 5-23(P)

CLIENT



Engineering Department  
151 Martin Street  
Birmingham, MI 48012

PROJECT LOCATION

Part of the Northeast 1/4  
of Section 36  
Town 2 North,  
Range 10 East  
City of Birmingham,  
Oakland County, Michigan

SHEET

Brown Street Paving Plan

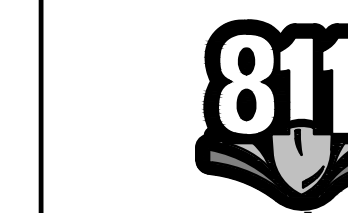

Know what's below  
Call before you dig.

DATE ISSUED/REVISED

12-08-22	ISSUED SURVEY
02-04-23	CONCEPT PLAN
02-14-23	UPDATED CONCEPT PLAN
03-16-23	90% CITY REVIEW
04-10-23	81DS
04-26-23	ADDENDUM 1

DRAWN BY:

G. Viju

DESIGNED BY:

G. Viju

APPROVED BY:

B. Buchholz

DATE:

March 16, 2023

SCALE: 1" = 20'

20 10 0 10 20 30

NFE JOB NO.

SHEET NO.

D162-01

C8

**NEW PARKING METER POST & NEW STREET LIGHT SCHEDULE**  
BROWN STREET P.O.E. to 2+82

NORTH WEST		ITEM	STATUS
STA. 00+98.54	24.48' N.W.	PED. STREET LIGHT	NEW
STA. 01+42.91	24.07' N.W.	PED. STREET LIGHT	MAINTAIN
STA. 02+04.69	24.73' N.W.	INTERSECTION LIGHT	NEW
STA. 02+32.28	24.77' N.W.	PED. STREET LIGHT	NEW
STA. 02+76.79	24.94' N.W.	PED. STREET LIGHT	NEW

SOUTH EAST		ITEM	STATUS
STA. 01+11.05	24.67' S.E.	PED. STREET LIGHT	NEW
STA. 01+13.55	24.52' S.E.	PARKING METER POST	NEW
STA. 01+55.05	24.58' S.E.	PED. STREET LIGHT	NEW
STA. 01+57.54	24.43' S.E.	PARKING METER POST	NEW
STA. 01+85.37	19.02' S.E.	INTERSECTION LIGHTING	NEW
STA. 02+35.03	19.21' S.E.	PED. STREET LIGHT	NEW

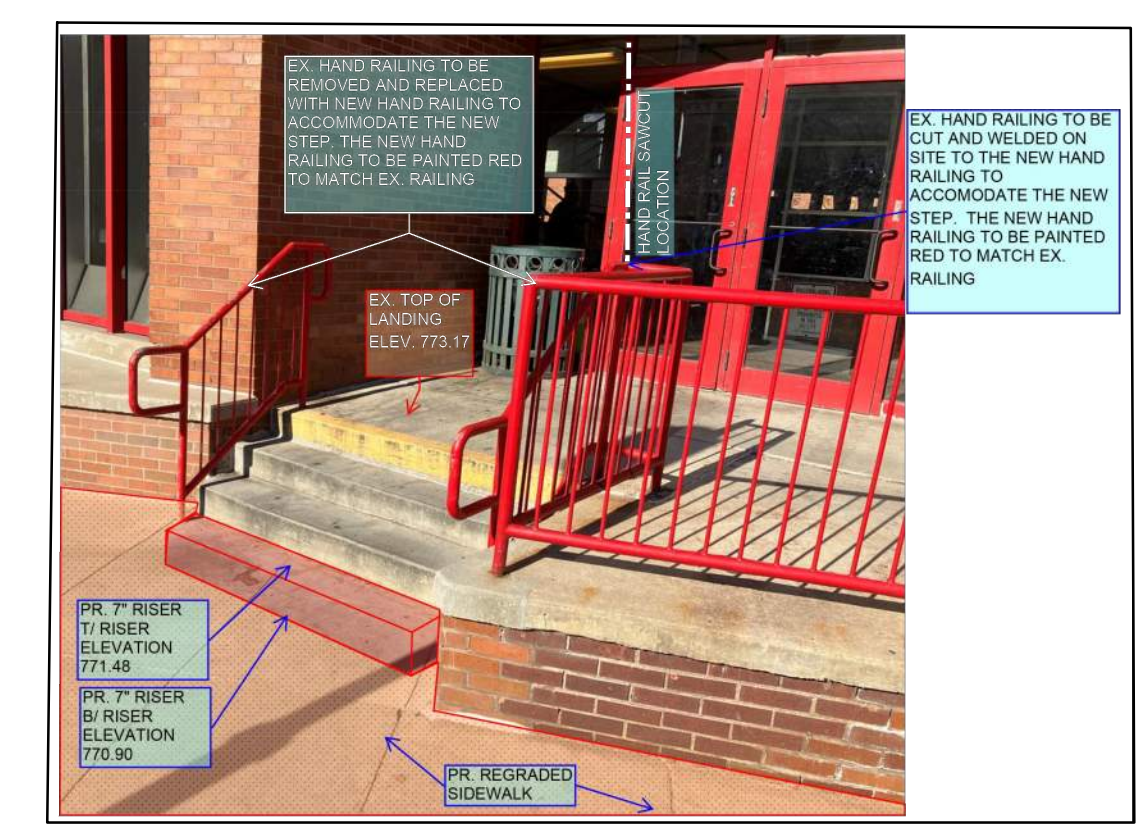

MODIFY STEPS & RAILING AT PEABODY PARKING STRUCTURE (LUMP SUM)

**REMOVAL NOTES & LEGEND**

R1	REMOVE EX. PAVEMENT FULL-DEPTH, INCLUDING CONC. CURB & GUTTER, EXCAVATE, AND INSTALL PR. PAVEMENT SECTIONS AS INDICATED (TYP.)
R2	REMOVE EX. SIDEWALK (INCLUDING EX. BRICK PAVEMENT WITH REINFORCED CONC. BASE AREAS) FULL-DEPTH, EXCAVATE & INSTALL PR. SIDEWALK SECTIONS AS INDICATED (TYP.)
R3	REMOVE & REPLACE EX. CONC. CURB & GUTTER AND INSTALL PR. 18" HD. CURB AND GUTTER PER M.D.O.T. DETAIL F2, MODIFIED (TYP.)

**PAVING NOTES & LEGEND**

P5	PR. SAWCUT 4" CONC. SIDEWALK (LIGHT BROOM FINISH)
P6	PR. CONC. PAVT. W/ INTEGRAL CURB (8" THICK ON BROWN)
P7	PR. FULL-DEPTH ASPHALT REPAIR (MATCH EX. CONDITIONS)
P8	PR. EXPOSED AGG. CONC. SIDEWALK
TH	THICKEN PR. CONC. WALK (6" & 8" THICK)
AS	PR. ADA TRUNCATED DOMES - STRAIGHT
AR	PR. ADA TRUNCATED DOMES - RADIAL
1	ALL RIMS OF STRUCTURES, SHUT-OFFS, HANDHOLES & BOXES SHALL BE FLUSH TO PROPOSED FINISHED GRADES (TYP.)
2	EXISTING SIDEWALK TO REMAIN & BE PROTECTED (OUTSIDE OF SHOWN REPAIR LIMITS) (TYP.)
3	PROPOSED BIRMINGHAM GREEN BENCH (TYP.)
4	PROPOSED MEDIAN ISLAND CURB & GUTTER, PER M.D.O.T. DETAIL F1/F2.
5	PROPOSED MEDIAN LANDSCAPE ISLAND (SEE L.S. PLAN FOR PLANTING DETAILS)
	PR. CURB & GUTTER, DETAIL F1/F2
	PR. EXP. AGG. PLANTER CURB (SEE L.S. PLAN FOR PLANTING DETAILS)
	PR. INTEGRAL CURB PER M.D.O.T. DETAIL F2, MOD.

**PAVING LEGEND**

[Pattern]	PROPOSED 4" EXPOSED AGGREGATE SIDEWALK
[Pattern]	PROPOSED 4" STANDARD SIDEWALK W/ SAWCUT PATTERN
[Pattern]	PROPOSED 8" CONCRETE PAVEMENT W/ INT. CURB
[Pattern]	PROPOSED ASPHALT PAVEMENT
[Pattern]	PROPOSED WALK BOX-OUT FOR TREE/MULCH

**LEGEND**

[Symbol]	MANHOLE	EXISTING SANITARY SEWER
[Symbol]	HYDRANT	SAN. CLEAN OUT
[Symbol]	MANHOLE CATCH BASIN	EXISTING WATERMAIN
[Symbol]	UTILITY POLE	EXISTING STORM SEWER
[Symbol]	GUY POLE	EX. R. Y. CATCH BASIN
[Symbol]	GUY WIRE	EXISTING BURIED CABLES
[Symbol]	OVERHEAD LINES	EXISTING LIGHT POLES
[Symbol]	SIGN	EXISTING GAS MAIN
[Symbol]	C.O. MANHOLE	PR. SANITARY SEWER
[Symbol]	CHYDRANT	PR. WATER MAIN
[Symbol]	INLET	PR. STORM SEWER
[Symbol]	C.B. MANHOLE	PR. R. Y. CATCH BASIN
[Symbol]		PROPOSED LIGHT POLE
[Symbol]		PROPOSED TREE GRATE
[Symbol]		PR. INTERSECTION LIGHT POLE
[Symbol]		PR. PEDESTRIAN LIGHT POLE
[Symbol]		PR. PARKING METER

**NEW PARKING METER POST & NEW STREET LIGHT SCHEDULE**  
BROWN STREET 2+82 to P.O.E.

NORTH WEST		ITEM	STATUS
STA. 03+00.63	48.24' N.	INTERSECTION LIGHT	NEW
STA. 03+55.34	16.46' N.	INTERSECTION LIGHT	NEW
STA. 03+77.23	17.45' N.	PED. STREET LIGHT	MAINTAIN
STA. 04+04.85	16.08' N.	PED. STREET LIGHT	MAINTAIN
STA. 04+36.29	17.03' N.	PED. STREET LIGHT	MAINTAIN

SOUTH EAST		ITEM	STATUS
STA. 02+89.00	18.18' S.	INTERSECTION LIGHT	NEW
STA. 03+77.23	17.45' S.	PED. STREET LIGHT	NEW
STA. 04+19.15	16.37' S.	PED. STREET LIGHT	NEW



SEAL

PROJECT  
Brown Street Paving Project  
Contract #5-23(P)

CLIENT  
  
**BIRMINGHAM**  
A WALKABLE CITY

Engineering Department  
151 Martin Street  
Birmingham, MI 48012

PROJECT LOCATION  
Part of the Northeast 1/4  
of Section 36  
Town 2 North,  
Range 10 East  
City of Birmingham,  
Oakland County, Michigan

SHEET  
Existing & Proposed  
Cross-Section



Know what's below  
Call before you dig.

DATE ISSUED/REVISD  
03-16-2023 - 90% CITY REVIEW  
04-10-2023 - BIDS

DRAWN BY:  
G. Viju  
DESIGNED BY:  
G. Viju  
APPROVED BY:  
B. Buchholz  
DATE:  
03-16-2023  
SCALE: N.T.S.

NFE JOB NO. SHEET NO.  
D162-01 C9

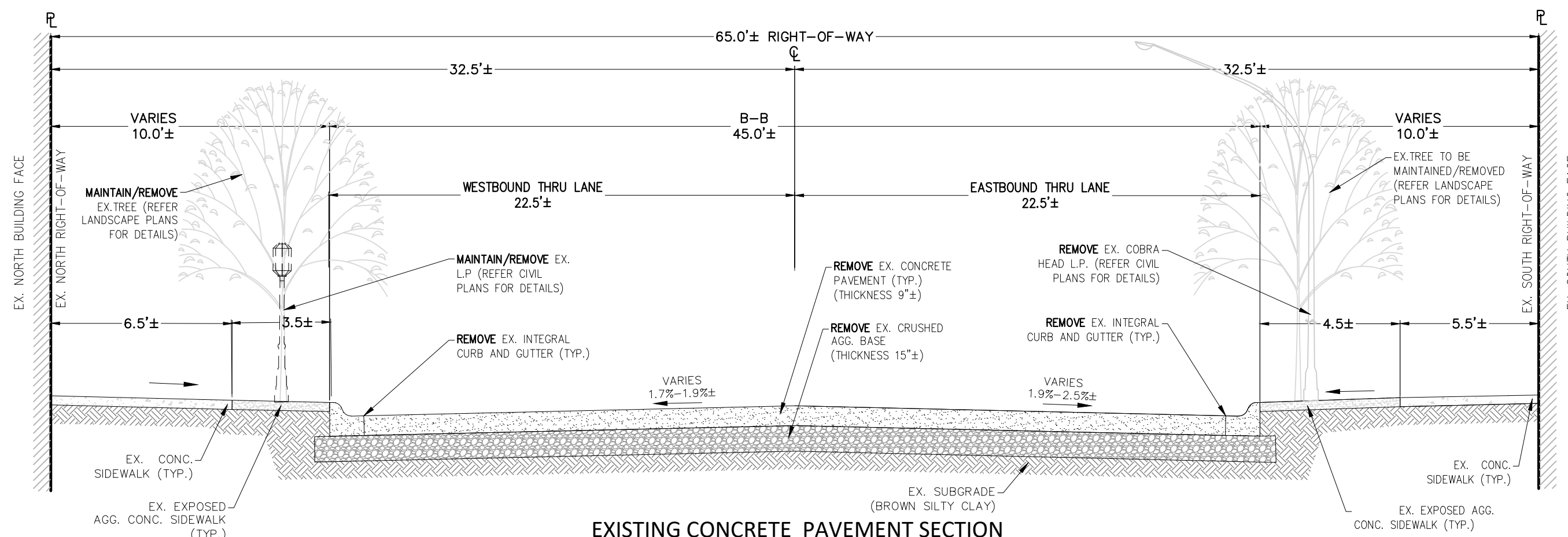

EXISTING CONCRETE PAVEMENT SECTION

N.T.S.  
**E. BROWN STREET**  
APPLIES TO: STA. P.O.B. TO 3+00

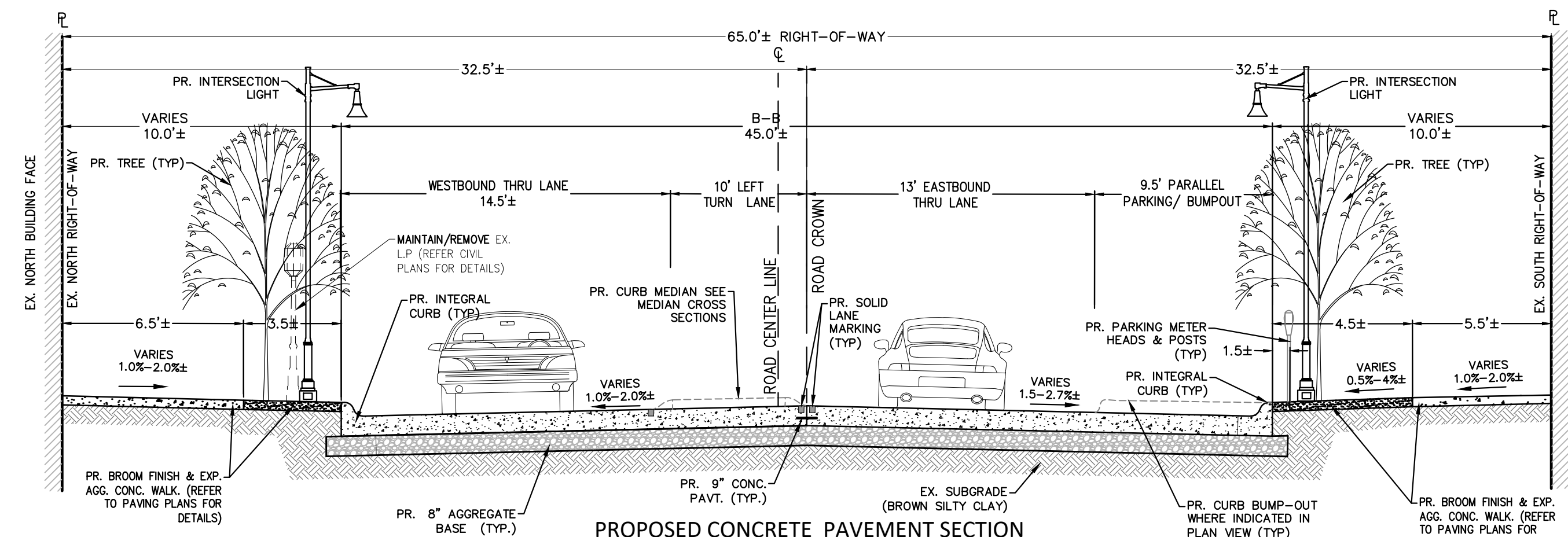

PROPOSED CONCRETE PAVEMENT SECTION

N.T.S.  
**E. BROWN STREET**  
APPLIES TO: STA. P.O.B. TO 3+00

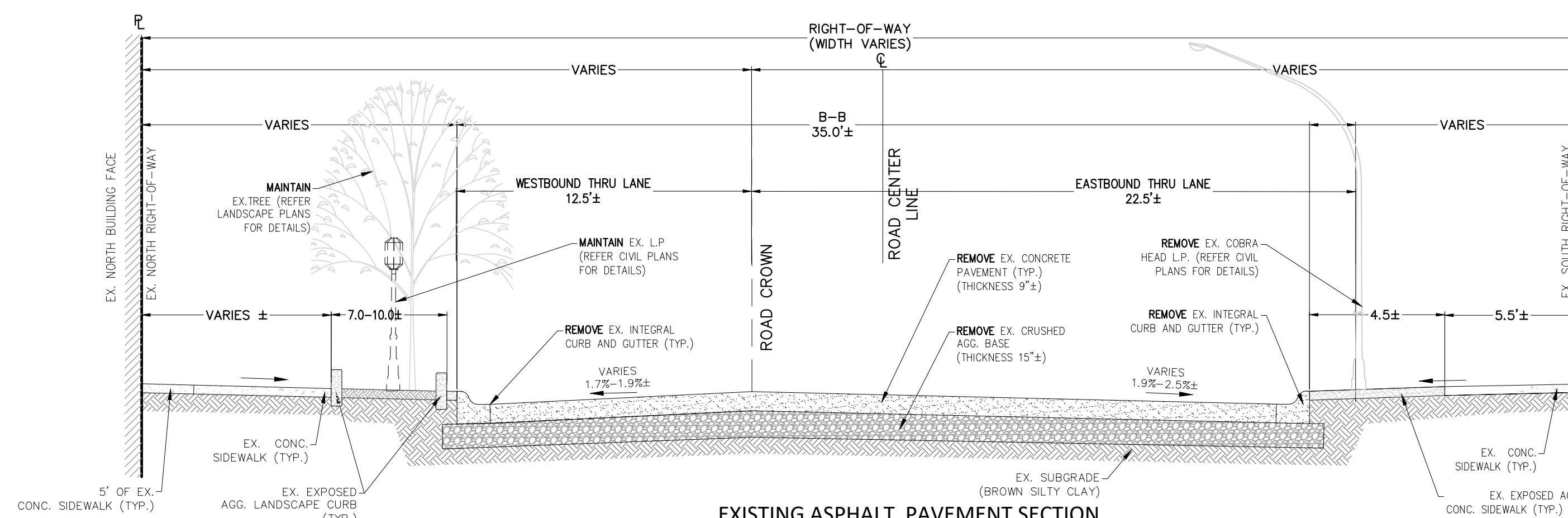

EXISTING ASPHALT PAVEMENT SECTION

N.T.S.  
**E. BROWN STREET**  
APPLIES TO: STA. 3+00. TO P.O.E.

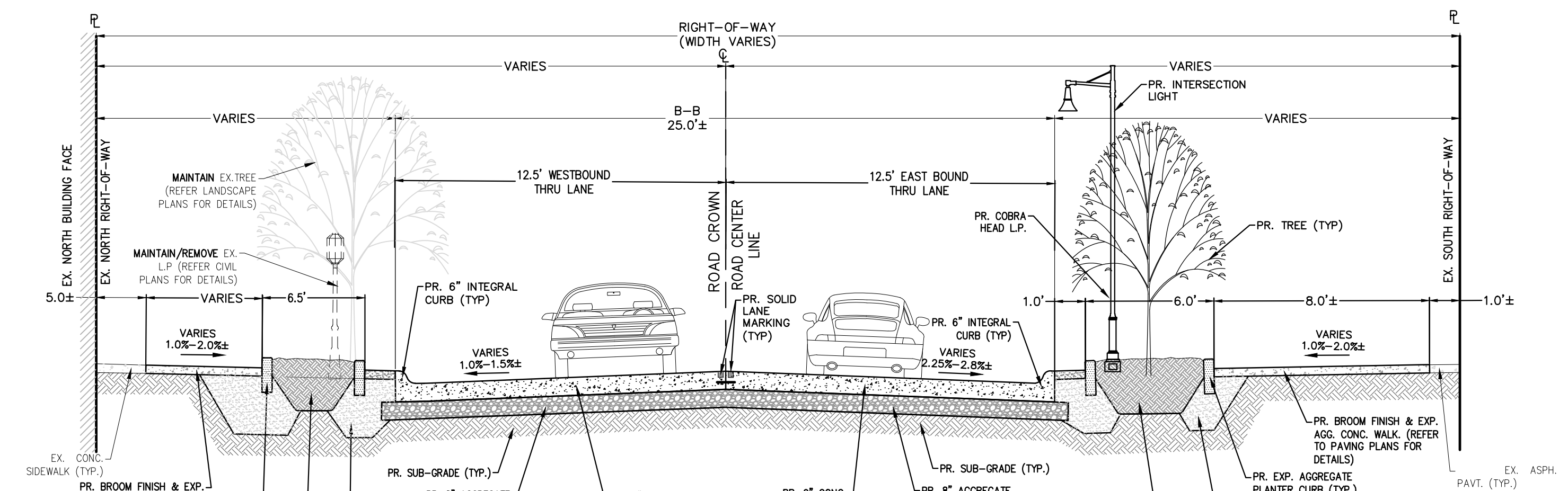

PROPOSED CONCRETE PAVEMENT SECTION

N.T.S.  
**E. BROWN STREET**  
APPLIES TO: STA. 3+00. TO P.O.E.

SEAL

PROJECT  
Brown Street Paving Project  
Contract # 5-23(P)

CLIENT



Engineering Department  
151 Martin Street  
Birmingham, MI 48012

PROJECT LOCATION

Part of the Northeast 1/4  
of Section 36  
Town 2 North,  
Range 10 East  
City of Birmingham,  
Oakland County, Michigan

SHEET

Brown Street Striping and  
Signage Plan



Know what's below  
Call before you dig.

DATE ISSUED/REVISED

12-08-22 ISSUED SURVEY  
02-04-23 CONCEPT PLAN  
02-14-23 UPDATED CONCEPT PLAN  
03-16-23 90% CITY REVIEW  
04-10-23 RIDS  
04-26-23 ADDENDUM 1

DRAWN BY:  
G. Viju

DESIGNED BY:  
G. Viju

APPROVED BY:  
B. Buchholz

DATE:  
March 16, 2023

SCALE: 1" = 20'

20 10 0 10 20 30

NFE JOB NO. SHEET NO.  
D162-01 C10

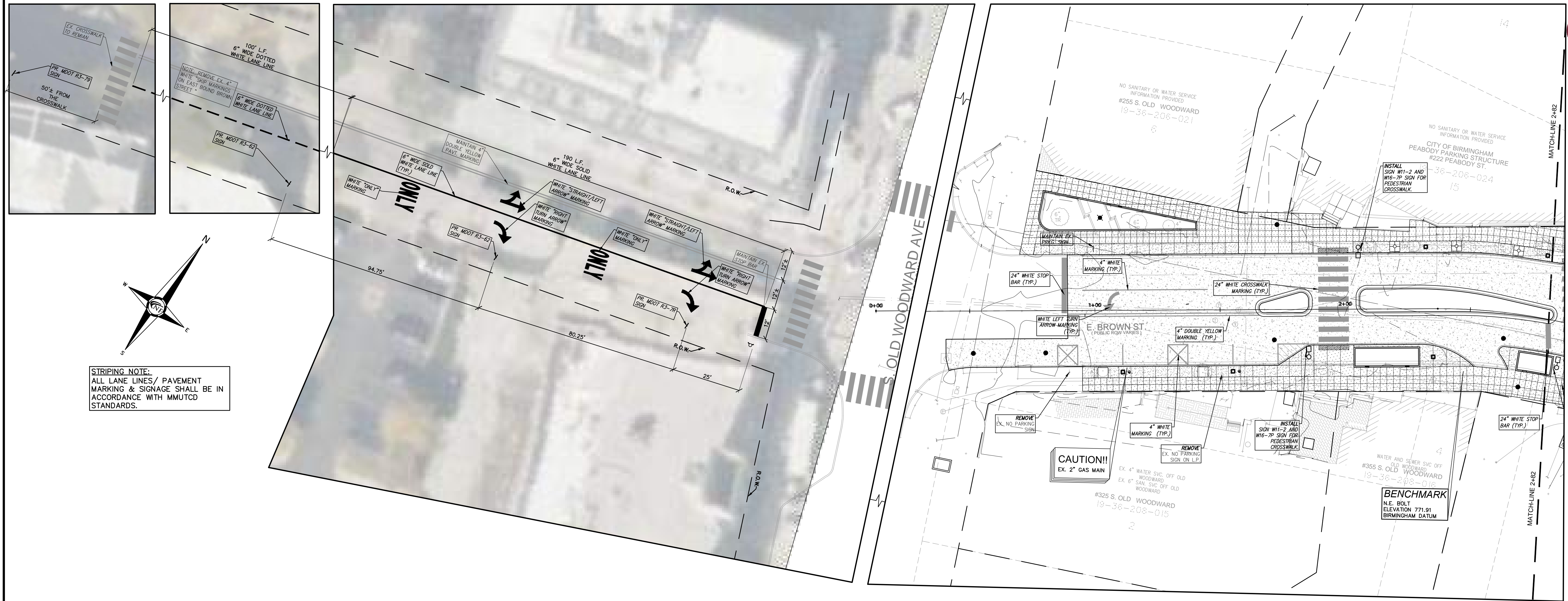

STRIPING NOTE:  
ALL LANE LINES/ PAVEMENT MARKING & SIGNAGE SHALL BE IN ACCORDANCE WITH MMUTCD STANDARDS.



SIGN DETAIL-R3-7R (30" x 30")

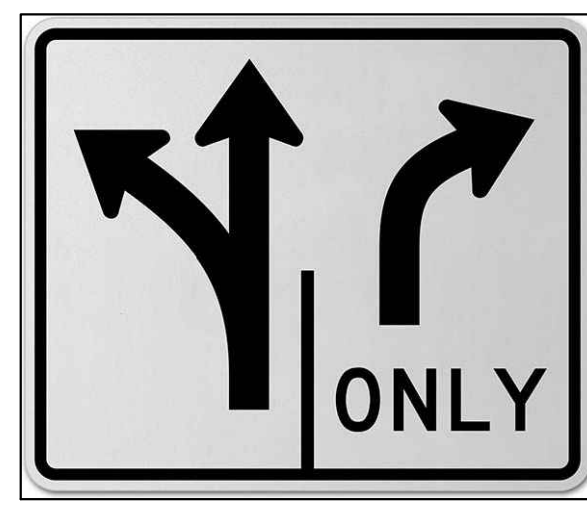

SIGN DETAIL-R3-62 (36" x 30")



SIGN DETAIL-R10-6 (18" x 24")



SIGN DETAIL-R1-1 (30" x 30")



SIGN DETAIL W16-7p DETAIL (30" x 18")



SIGN DETAIL W11-2 DETAIL (30" x 30")

NOTE:  
ALL SIGN BACKS & U-CHANNEL POSTS SHALL BE PAINTED BIRMINGHAM GREEN

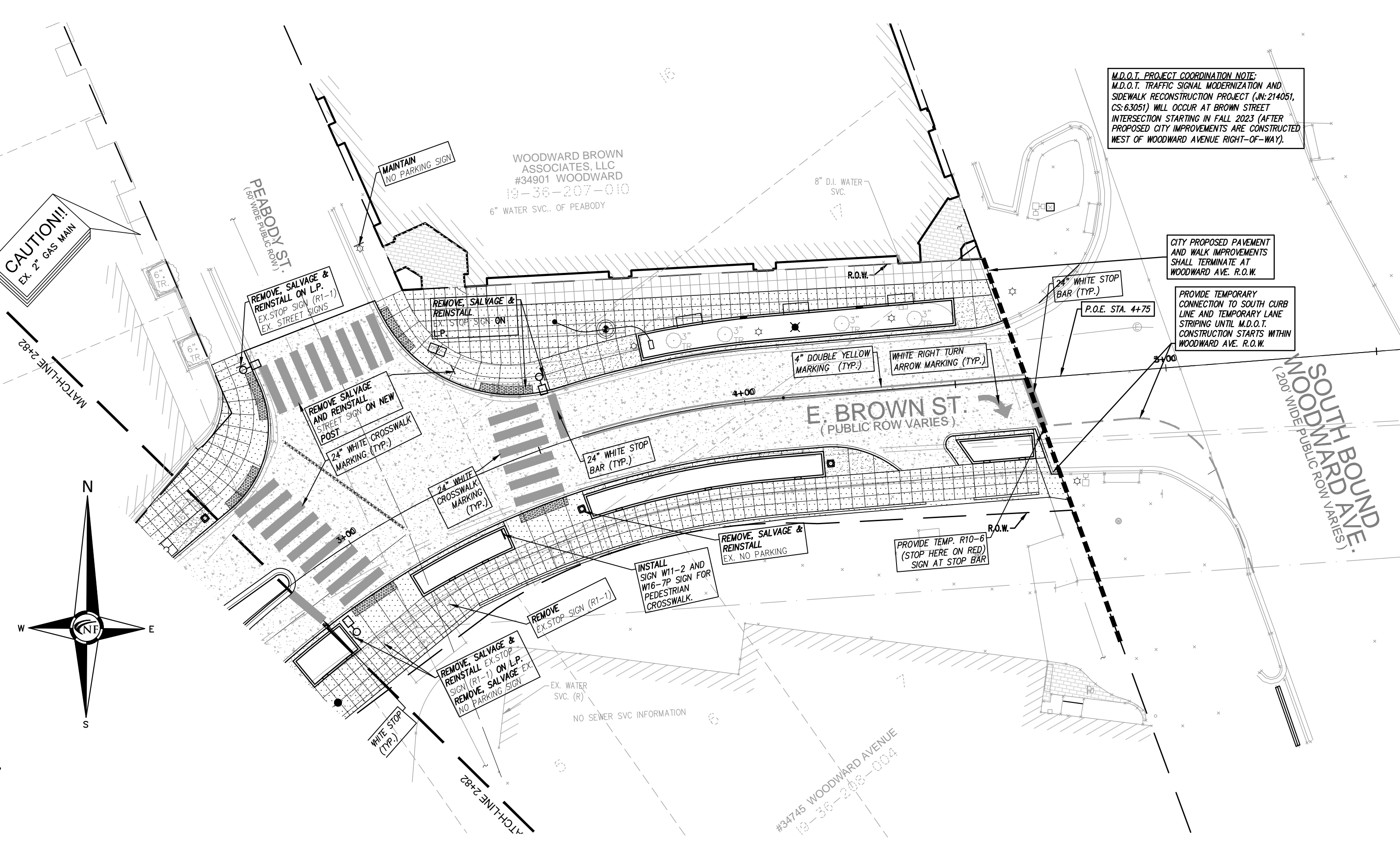

PAVING LEGEND

	PROPOSED 4" EXPOSED AGGREGATE SIDEWALK
	PROPOSED 4" STANDARD SIDEWALK W/ SAWCUT PATTERN
	PROPOSED 8" CONCRETE PAVEMENT W/ INT. CURBS
	PROPOSED ASPHALT PAVEMENT
	PROPOSED WALK BOX-OUT FOR TREE/MULCH

LEGEND

	MANHOLE		EXISTING SANITARY SEWER
	HYDRANT		SAN. CLEAN OUT
	MANHOLE CATCH BASIN		EXISTING WATERMAIN
	UTILITY POLE		EXISTING STORM SEWER
	GUY POLE		EX. R. Y. CATCH BASIN
	LIGHT POLE		EXISTING BURIED CABLES
	SIGN		OVERHEAD LINES
	EXISTING GAS MAIN		GUY WIRE
	C.O.		PROPOSED LIGHT POLE
	MANHOLE		PROPOSED TREE GRATE
	HYDRANT		
	INLET		
	C.B.		
	MANHOLE		
	PR. R. Y. CATCH BASIN		
	PR. SANITARY SEWER		
	PR. WATER MAIN		
	PR. STORM SEWER		



SEAL

PROJECT  
 Brown Street Paving Project  
 Contract #5-23(P)

CLIENT  
  
**BIRMINGHAM**  
 A WALKABLE CITY

Engineering Department  
 151 Martin Street  
 Birmingham, MI 48012

PROJECT LOCATION  
 Part of the Northeast 1/4  
 of Section 36  
 Town 2 North,  
 Range 10 East  
 City of Birmingham,  
 Oakland County, Michigan

SHEET  
 Brown Street -Detour Plan



Know what's below  
 Call before you dig.

DATE	ISSUED/REVISED
03-16-2023	- 90% CITY REVIEW
04-10-2023	- BIDS
04-26-2023	- ADDENDUM 1

DRAWN BY:  
 G. Viju

DESIGNED BY:  
 G. Viju

APPROVED BY:  
 B. Buchholz

DATE:  
 03-16-2023

SCALE: N.T.S.

NFE JOB NO.  
**D162-01**

SHEET NO.  
**C11**

**BROWN STREET CLOSED  
 OLD WOODWARD TO  
 WOODWARD**

36" x 72" ADVANCE WARNING SIGN "A"  
 BLACK LEGEND ON ORANGE BACKGROUND

**BROWN STREET CLOSED  
 OLD WOODWARD TO  
 WOODWARD  
 FOLLOW DETOUR**

36" x 72" ADVANCE WARNING SIGN "B"  
 BLACK LEGEND ON ORANGE BACKGROUND

10" x 30"  
 ADVANCED WARNING SIGN "C"  
 BLACK LEGEND ON ORANGE  
 BACKGROUND  
**WOODWARD AVE. (M1)**

10" x 30"  
 ADVANCED WARNING SIGN "D"  
 BLACK LEGEND ON ORANGE  
 BACKGROUND  
**SB. WOODWARD (M1)**

10" x 30"  
 ADVANCED WARNING SIGN "E"  
 BLACK LEGEND ON ORANGE  
 BACKGROUND  
**SB. OLD WOODWARD**

10" x 30"  
 ADVANCED WARNING SIGN "F"  
 BLACK LEGEND ON ORANGE  
 BACKGROUND  
**NB. WOODWARD (M1)**

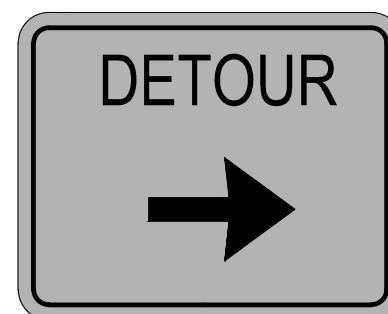
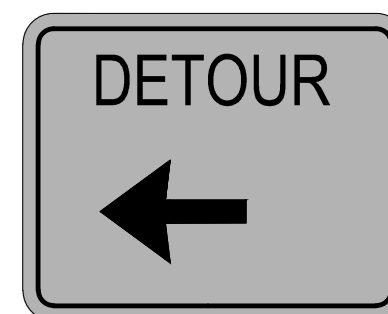
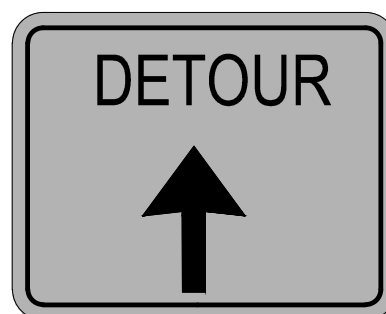

30" x 24"  
 ADVANCED WARNING SIGN "G"  
 BLACK LEGEND ON ORANGE  
 BACKGROUND  
 (PER. M.D.O.T. M4-9U)  
 (MOUNT BELOW WARNING  
 SIGN "C/D/E/F" WHERE INDICATED)

30" x 24"  
 ADVANCED WARNING SIGN "H"  
 BLACK LEGEND ON ORANGE  
 BACKGROUND  
 (PER. M.D.O.T. M4-9L)  
 (MOUNT BELOW WARNING  
 SIGN "C/D/E/F" WHERE INDICATED)

30" x 24"  
 ADVANCED WARNING SIGN "I"  
 BLACK LEGEND ON ORANGE  
 BACKGROUND  
 (PER. M.D.O.T. M4-9R)  
 (MOUNT BELOW WARNING  
 SIGN "C/D/E/F" WHERE INDICATED)

**END  
 DETOUR**

24" x 18"  
 ADVANCED WARNING SIGN "J"  
 BLACK LEGEND ON ORANGE BACKGROUND

**BROWN STREET CLOSED  
 OLD WOODWARD TO  
 WOODWARD  
 SEEK ALT ROUTE**

**SIDEWALK  
 CLOSED**  
 18" x 30"  
 ADVANCE WARNING SIGN "L"  
 BLACK LEGEND ON ORANGE  
 BACKGROUND

36" x 72" ADVANCE WARNING SIGN "K"  
 BLACK LEGEND ON ORANGE BACKGROUND

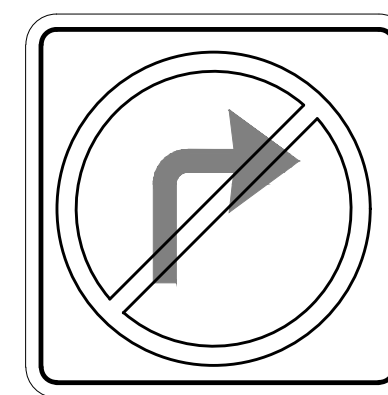

ADVANCED WARNING SIGN "O"  
 R3-1

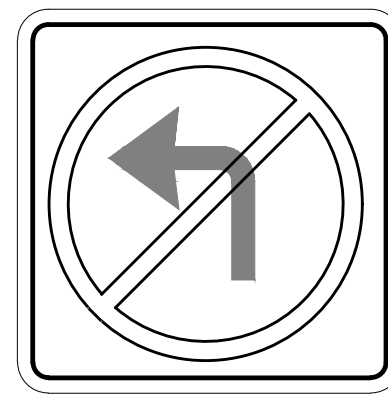

ADVANCED WARNING SIGN "P"  
 R3-2



36" x 36"  
 ADVANCE WARNING SIGN "M"  
 BLACK LEGEND ON ORANGE  
 BACKGROUND

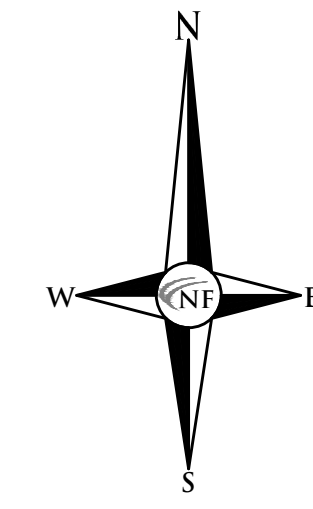
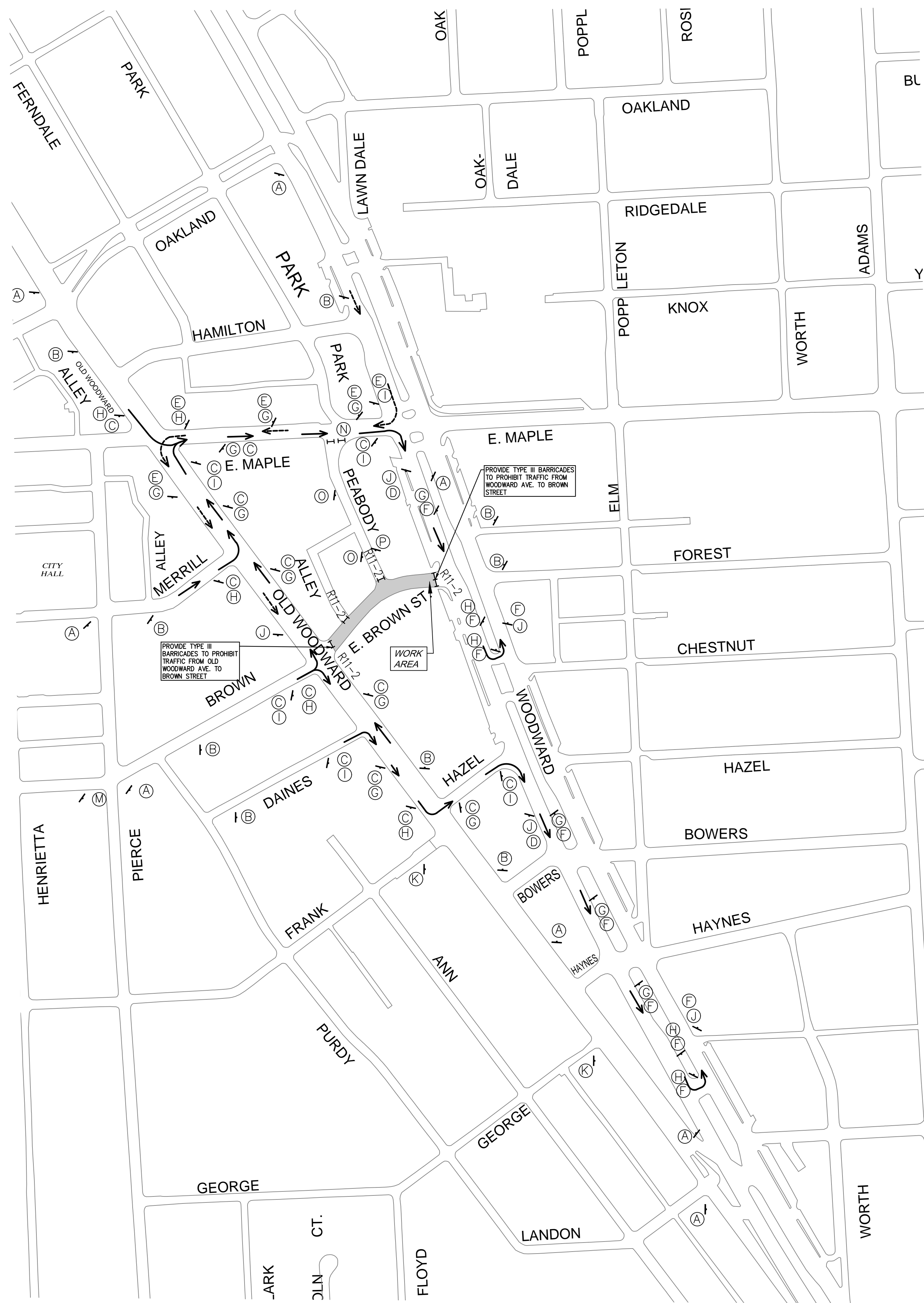

SPECIAL ADVANCED WARNING SIGN QUANTITIES			
DESIGNATION	DESCRIPTION	SIZE	QUANTITY
SIGN "A"	BROWN STREET CLOSED OLD WOODWARD TO WOODWARD	36"x72"	7
SIGN "B"	BROWN STREET CLOSED OLD WOODWARD TO WOODWARD FOLLOW DETOUR	36"x72"	9
SIGN "C"	WOODWARD AVE.(M1)	10"x30"	15
SIGN "D"	S.B. WOODWARD (M1)	10"x30"	2
SIGN "E"	S.B. OLD WOODWARD	10"x30"	5
SIGN "F"	N.B. WOODWARD (M1)	10"x30"	10
SIGN "G"	DETOUR W/ UP ARROW (M.D.O.T. M4-9U)	30"x24"	13
SIGN "H"	DETOUR W/ LEFT ARROW (M.D.O.T. M4-9L)	30"x24"	8
SIGN "I"	DETOUR W/ RIGHT ARROW (M.D.O.T. M4-9R)	30"x24"	5
SIGN "J"	END DETOUR	24"x18"	5
SIGN "K"	BROWN STREET CLOSED O.W.W. TO WOODWARD SEEK ALT ROUTE	36"x72"	2
SIGN "L"	SIDEWALK CLOSED	18"x30"	6
SIGN "M"	ROAD CLOSED AHEAD	10"x30"	2
SIGN "N"	ROAD CLOSED TO THRU TRAFFIC	18"x24"	1
SIGN "O"	NO RIGHT TURN (M.D.O.T. R3-1)	30"x24"	2
SIGN "P"	NO LEFT TURN (M.D.O.T. R3-2)	30"x24"	1
OTHER ADVANCED WARNING SIGN QUANTITIES AS SHOWN			
DESIGNATION	DESCRIPTION	SIZE	QUANTITY
R11-2	ROAD CLOSED	48"x30"	9

**SYMBOL KEY**

	TYPE III BARRICADES
	ADVANCED WARNING SIGN
	DETOUR ROUTE (N.B./S.B. O.W.W.)
	DETOUR ROUTE (N.B./S.B. W.W.)

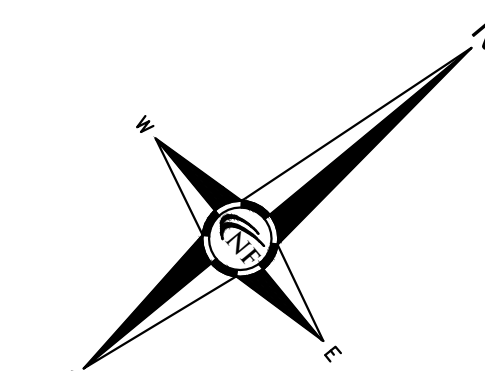

SEAL

PROJECT  
Brown Street Paving Project  
Contract #5-23(P)



Engineering Department  
151 Martin Street  
Birmingham, MI 48012

PROJECT LOCATION  
Part of the Northeast 1/4  
of Section 36  
Town 2 North,  
Range 10 East  
City of Birmingham,  
Oakland County, Michigan

SHEET  
Pedestrian Access &  
Traffic Maintenance Plan



Know what's below  
Call before you dig.

DATE ISSUED/REVISED  
03-16-23 90% CITY REVIEW  
04-10-23 BIDS

DRAWN BY:  
G. Viju  
DESIGNED BY:  
G. Viju  
APPROVED BY:  
B. Buchholz  
DATE:  
March 16, 2023  
SCALE: 1" = 20'  
NFE JOB NO. SHEET NO.  
D162-01 C12

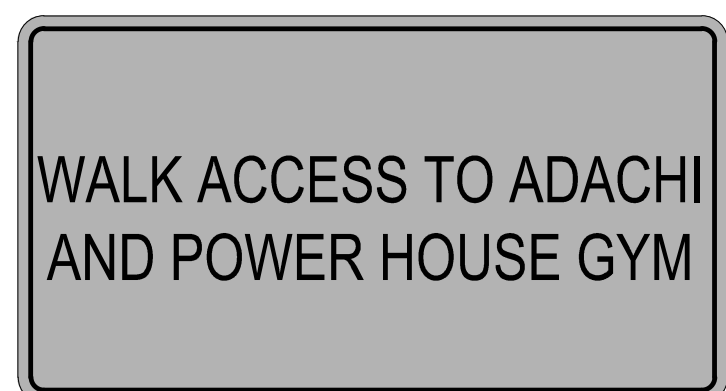
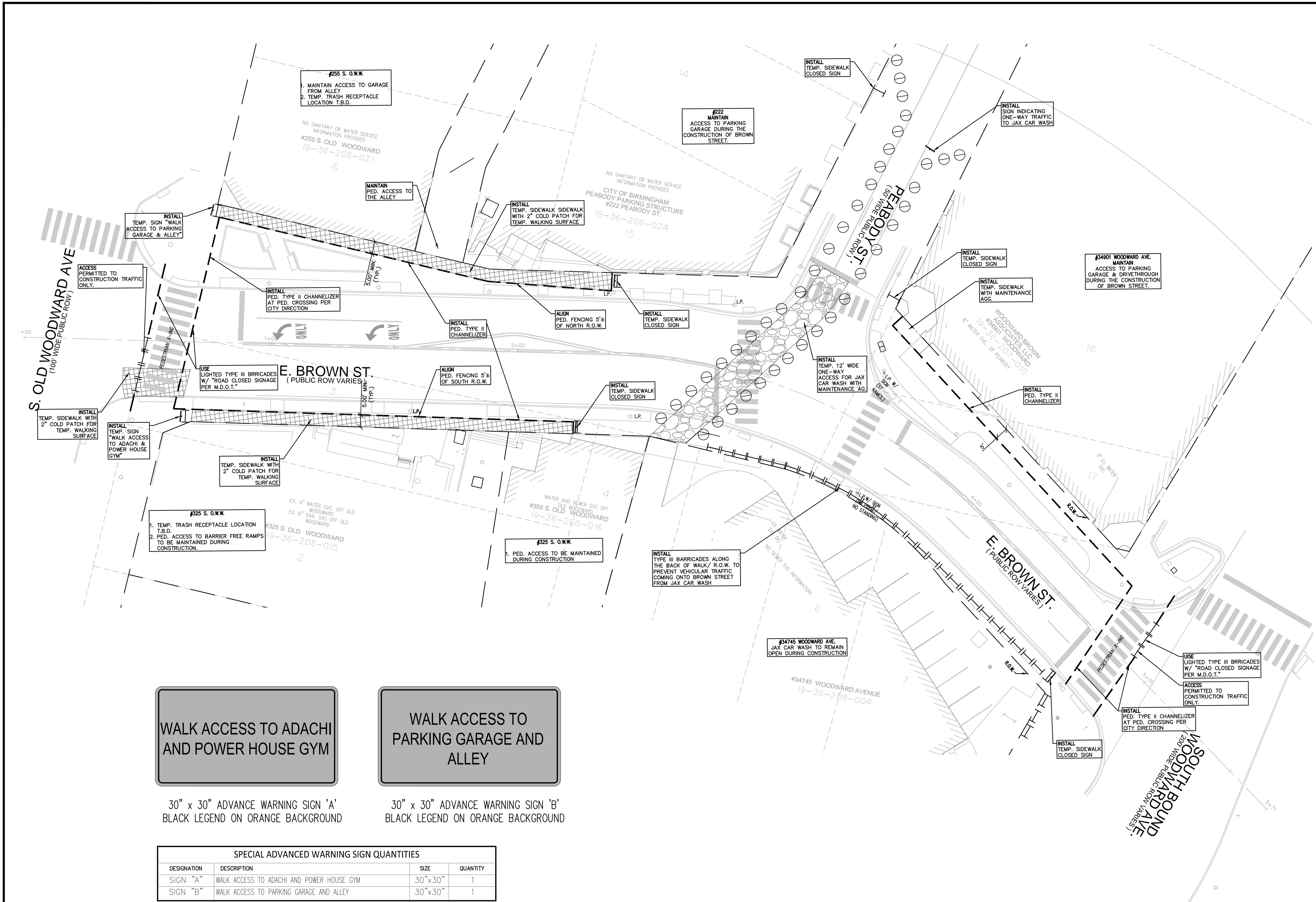

30" x 30" ADVANCE WARNING SIGN 'A'  
BLACK LEGEND ON ORANGE BACKGROUND

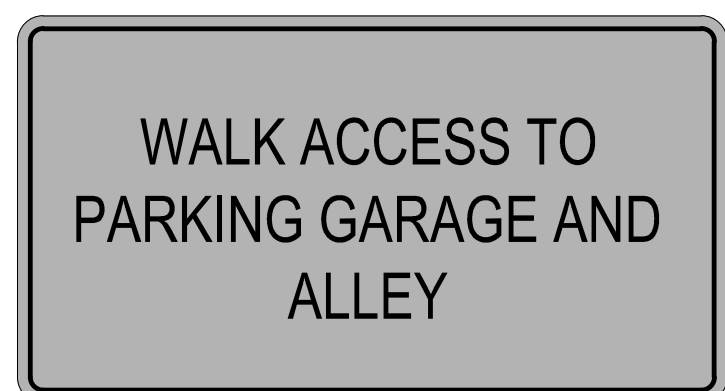

30" x 30" ADVANCE WARNING SIGN 'B'  
BLACK LEGEND ON ORANGE BACKGROUND

SPECIAL ADVANCED WARNING SIGN QUANTITIES			
DESIGNATION	DESCRIPTION	SIZE	QUANTITY
SIGN "A"	WALK ACCESS TO ADACHI AND POWER HOUSE GYM	30"x30"	1
SIGN "B"	WALK ACCESS TO PARKING GARAGE AND ALLEY	30"x30"	1

- PEDESTRIAN TRAFFIC CONTROL NOTES:**
1. THE CONTRACTOR SHALL PROVIDE SUFFICIENT MANPOWER TO MAINTAIN SAFE PEDESTRIAN TRAFFIC PATTERNS AND ACCESS TO BUSINESSES, AND PREVENT PEDESTRIANS FROM ENTERING THE CONSTRUCTION AREAS THROUGHOUT THE DURATION OF THE PROJECT (PAID AS "PEDESTRIAN TRAFFIC CONTROL", LUMP SUM).
  2. PEDESTRIAN TRAFFIC ROUTES SHALL BE DESIGNATED "PEDESTRIAN TYPE II CHANNELIZERS, TEMP" AS DEPICTED ON THIS PLAN, OR AS REQUIRED BY CITY.
  3. PEDESTRIAN CROSSING LOCATIONS MAY BE REQUIRED TO BE SHIFTED THROUGHOUT THE PROJECT, DEPENDING ON WORK TASKS REQUIRED IN VARIOUS LOCATIONS, SCHEDULE OF OPERATIONS, ETC.
  4. TEMPORARY SIGNAGE AND SUPPLEMENTARY TRAFFIC CONTROLS SHALL BE PROVIDED AS NECESSARY TO NOTIFY PEDESTRIANS OF TEMPORARY WALK CLOSURES & PEDESTRIAN DETOUR ROUTES.

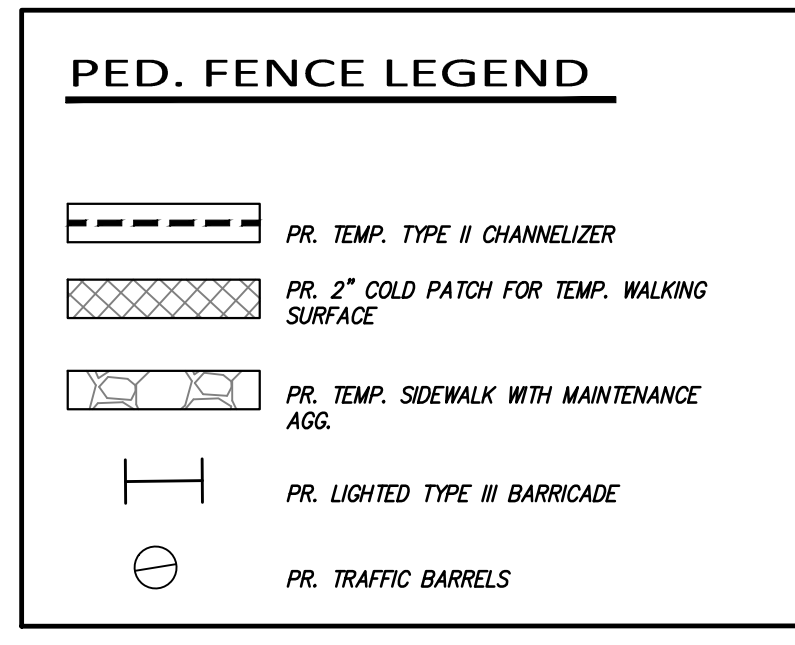

- BRICK PAVERS IN PUBLIC S.W. AREA SHALL BE REMOVED & DISPOSED OF AS DIRECTED BY CITY. ON PRIVATE PROPERTY BRICK PAVERS SHALL BE REMOVED AND STOCKPILED FOR REINSTALLATION AS DIRECTED BY CITY.
- ALL PAVEMENT TO BE REMOVED SHALL BE SAWCUT FULL DEPTH.
- ANY GRAVEL REPLACEMENT NECESSARY FOR REGRADING DRIVEWAYS SHALL BE CONSIDERED INCLUDED IN THE COST OF CONCRETE DRIVE APPROACH.
- ALL TREES NOT INDICATED FOR REMOVAL SHALL BE PROTECTED DURING CONSTRUCTION. WHERE NECESSARY, TREE ROOTS SHALL BE CUT CLEANLY. AT NO TIME WILL RIPPING OR TEARING OF TREE ROOTS BE ACCEPTABLE.
- ALL DRIVEWAYS (BEHIND THE SIDEWALK) SHALL BE REPAIRED WITH A CROSS SECTION WHICH MATCHES THE EXISTING IN THICKNESS, OR A MINIMUM 4.0" BITUMINOUS MIXTURE NO. 13A. IF THE EXISTING DRIVEWAY IS GREATER THAN 4.0" IN DEPTH, THE THICKNESS OF THE BITUMINOUS MIXTURE NO. 13A SHALL BE ADJUSTED TO MAKE UP THE DIFFERENCE.
- UNLESS OTHERWISE SHOWN, PROPOSED GRADES IN PROFILE ARE TOP OF CURB GRADES.
- ROCKS, OR OTHER MISC. DEBRIS WHICH ARE REMOVED SHALL BECOME THE PROPERTY OF THE CONTRACTOR AND SHALL BE REMOVED FROM THE SITE, UNLESS DIRECTED OTHERWISE FROM THE CITY.
- THE PAY ITEM "ADJUST STRUCTURE COVER" APPLIES ONLY TO PRE-EXISTING STRUCTURES TO BE ADJUSTED TO PROPOSED GRADES AS PART OF CONSTRUCTION.
- IF THE CONTRACTOR HAS MULTIPLE CREWS WORKING THAT REQUIRES MULTIPLE CITY INSPECTORS ON A GIVEN WORK DAY, THE PAY ITEM "INSPECTOR CREW DAYS" SHALL BE MULTIPLIED BY THE CORRESPONDING NUMBER OF INSPECTORS REQUIRED DURING SAID WORK DAY.

**PAVING NOTES**

- PAVEMENT SHALL BE OF THE TYPE, THICKNESS AND CROSS SECTION AS INDICATED ON THE PLANS AND AS FOLLOWS:

CONCRETE ROAD/PARKING: BASE COURSE - 21AA CRUSHED LIMESTONE AGGREGATE (8" THICK)  
MIX - PORTLAND CEMENT TYPE IA (AIR-ENRAINED), TO COMPLY WITH MDOT 3500HP REQUIREMENTS (8" THICK ROAD TRAVEL LANES, 7" THICK ROAD PARKING AREAS).

CONCRETE FLATWORK REQUIREMENTS: PORTLAND CEMENT TYPE IA (AIR-ENRAINED), TO COMPLY WITH MDOT 3500

ALL CONCRETE PAVEMENT AND FLATWORK MIXES USED ON THIS PROJECT SHALL COMPLY WITH A MINIMUM GROUND GRANULATED BLAST-FURNACE SLAG (GGBFS) SUBSTITUTION OF TWENTY-FIVE (25) PERCENT SUBJECT TO SEASONAL LIMITATIONS PER THE MICHIGAN DEPARTMENT OF TRANSPORTATION (MDOT) STANDARD SPECIFICATIONS FOR CONSTRUCTION, 2003 EDITION, OR USE LOW ALKALI (0.6% OR LESS TOTAL CEMENT ALKALI) TYPE I OR TYPE II CEMENT.

- PAVEMENT BASE SHALL BE COMPACTED TO 95% OF THE MAXIMUM DENSITY (MODIFIED PROCTOR) PRIOR TO PLACEMENT OF PROPOSED PAVEMENT. EXISTING SUB-BASE SHALL BE PROOF-ROLLED IN THE PRESENCE OF THE ENGINEER TO DETERMINE STABILITY.
- ALL CONCRETE PAVEMENT, DRIVEWAYS, CURB & GUTTER, ETC., SHALL BE SPRAY CURED WITH WHITE MEMBRANE CURING COMPOUND IMMEDIATELY FOLLOWING FINISHING OPERATION.
- ALL CONCRETE PAVEMENT JOINTS SHALL BE FILLED WITH HOT POURED RUBBERIZED ASPHALT JOINT SEALING COMPOUND IMMEDIATELY AFTER SAWCUT OPERATION. FEDERAL SPECIFICATION SS-5164.
- ALL WORKMANSHIP AND MATERIALS SHALL BE IN ACCORDANCE WITH THE CURRENT STANDARDS AND SPECIFICATIONS OF THE MUNICIPALITY AND THE MICHIGAN DEPARTMENT OF TRANSPORTATION STANDARD SPECIFICATIONS FOR CONSTRUCTION, 2003 EDITION.
- ALL TOP OF CURB ELEVATIONS, AS SHOWN ON THE PLANS, ARE CALCULATED FOR A 6" CONCRETE CURB UNLESS OTHERWISE NOTED.
- ALL SIDEWALK RAMPS, CONFORMING TO PUBLIC ACT NO. 8, 1993, SHALL BE INSTALLED AS INDICATED ON THE PLANS.
- CONSTRUCTION OF A NEW OR RECONSTRUCTED DRIVE APPROACH CONNECTING TO AN EXISTING STATE OR COUNTY ROADWAY SHALL BE ALLOWED ONLY AFTER AN APPROVED PERMIT HAS BEEN SECURED FROM THE AGENCY HAVING JURISDICTION OVER SAID ROADWAY.
- FOR ANY WORK WITHIN THE PUBLIC RIGHT-OF-WAY, THE CONTRACTOR SHALL PAY FOR AND SECURE ALL NECESSARY PERMITS AND LIKEWISE ARRANGE FOR ALL INSPECTION.
- EXISTING TOPSOIL, VEGETATION AND ORGANIC MATERIALS SHALL BE STRIPPED AND REMOVED FROM PROPOSED PAVEMENT AREA PRIOR TO PLACEMENT OF BASE MATERIALS (INCLUDED IN PAVING WORK).
- EXPANSION JOINTS SHOULD BE INSTALLED AT THE END OF ALL INTERSECTION RADII.
- SIDEWALK RAMPS, CONFORMING TO PUBLIC ACT NO. 8, 1973, SHALL BE INSTALLED AS SHOWN AT ALL STREET INTERSECTIONS AND AT ALL BARRIER FREE PARKING AREAS AS INDICATED ON THE PLANS.
- ALL PAVEMENT AREAS SHALL BE PROOF-ROLLED UNDER THE SUPERVISION OF A GEOTECHNICAL ENGINEER PRIOR TO THE PLACEMENT OF BASE MATERIALS AND PAVING MATERIALS.
- ALL AREAS SHALL BE MACHINE COMPACTED IN UNIFORM LIFTS NOT EXCEEDING 9 INCHES THICK TO 95% OF THE MAXIMUM DENSITY (MODIFIED PROCTOR) PRIOR TO PLACEMENT OF PROPOSED PAVEMENT.
- R.A.P. NOT ALLOWED IN SURFACE / TOP COURSE OF ASPHALT.

**WATER MAIN NOTES**

- ALL WATER MAINS 4" AND LARGER SHALL BE DUCTILE IRON PIPE THICKNESS CLASS 54, WITH PUSH ON TYPE JOINTS AND CEMENT LINED (DOUBLE THICKNESS).
- NEW WATER MAINS SHALL BE INSTALLED WITH A MINIMUM 5 FEET OF COVER. EXCEPTIONS WILL BE ALLOWED WHEN NECESSARY TO CONNECT TO EXISTING MAIN OR WHEN AUTHORIZED BY THE ENGINEER.
- KNOWN WATER SERVICES BASED ON FIELD INFORMATION OR CITY RECORDS ARE SHOWN ON THE PLANS AS FOLLOWS: "C" = COPPER, "L" = LEAD AND "W.S." = WATER SERVICE TYPE UNKNOWN. THE CONTRACTOR SHALL BE RESPONSIBLE FOR CONNECTING ALL EXISTING SERVICES TO THE NEW MAIN AFTER IT HAS BEEN APPROVED FOR USE.
- COAT ALL BOLTS ON MECHANICAL FITTINGS WITH TAR.
- HYDRANT CONNECTION TO CONSIST OF 6" DUCTILE IRON PIPE, 6" GATE VALVE AND BOX, AND HYDRANT. HYDRANT SHALL BE EJM MODEL 58R WITH 6" MECHANICAL JOINT INLET, TWO PUMPER INLETS, ALL OPENING LEFT, 5"-6" TRENCH, PLUGGED DRAIN AND BLOCK BOLTS.
- INSTALL GATE VALVE AS CLOSE TO HYDRANT AS PRACTICABLE.
- GATE VALVES 4" AND LARGER MAY BE MUELLER BRAND SPECIFIED, OR APPROVED EQUIVALENT. ALL MATERIALS RELATIVE TO WATER SERVICE CONNECTIONS SHALL BE MUELLER BRAND.
- IN ABANDONING MAINS, THE FOLLOWING SHALL BE DONE: PLUG ALL OPEN PIPE ENDS WITH MASONRY, DISCONNECT MAINS WHICH ARE TO BE ABANDONED FROM FITTINGS AT LIVE MAINS AND BLOCK THOSE FITTINGS. FILL MAIN TO BE ABANDONED WITH GROUT OR HYDRAULIC CEMENT.
- WORK INDICATED BY (A) SHALL BE PERFORMED AFTER THE NEW MAINS ARE PLACED IN SERVICE.
- THE LOCATIONS AND TYPES OF SERVICE LEADS IS BASED ON THE BEST AVAILABLE INFORMATION. THE EXACT LOCATION OF SERVICE LEADS SHALL BE FIELD VERIFIED BY THE CONTRACTOR.
- WHERE APPLICABLE, THE APPROPRIATE SECTIONS OF EXISTING WATERMAIN SHALL BE SHUTDOWN AND DEPRESSURIZED PRIOR TO A) CUTTING AND REMOVING, B) CUTTING AND INSTALLING PROPOSED TEE CONNECTIONS, C) PERFORMING ANY AND ALL OTHER WORK AROUND/ADJACENT TO HYDRANTS AND ALL OTHER CONNECTIONS, WHILE MEETING AND/OR EXCEEDING APPLICABLE INDUSTRY SAFETY PRECAUTIONS AND MISHA STANDARDS.

**STORM SEWER NOTES (where applicable)**

- ALL WORKMANSHIP AND MATERIALS SHALL BE IN ACCORDANCE WITH THE CURRENT STANDARDS AND SPECIFICATIONS OF THE MUNICIPALITY, THE MUNICIPALITY STANDARD NOTES, DETAILS AND SPECIFICATIONS SHALL BE INCORPORATED AS PART OF THESE PLANS.
- ALL STORM SEWER TRENCHES UNDER OR WITHIN THREE (3) FEET OF EXISTING OR PROPOSED PAVEMENT SHALL BE BACK FILLED WITH MDOT CLASS II MATERIAL (SAND) AND BE MACHINE COMPACTED TO A MINIMUM OF 95% OF THE MATERIAL'S MAXIMUM DENSITY. PAVEMENT SHALL INCLUDE PARKING LOTS, DRIVE APPROACHES, 95 CURB & GUTTER AND ADJACENT WALKS.
- ALL STORM SEWER PIPE SHALL BE INSTALLED ON CLASS "B" BEDDING OR BETTER UNLESS OTHERWISE INCLUDED ON THE PLANS.
- STORM SEWER SHALL BE OF THE TYPE, SIZE & CLASS DESIGNATION INDICATED ON THE PLANS AND LIKEWISE BE INSTALLED AT THE PROPOSED LINE & GRADE INDICATED.
- ALL STORM SEWER PIPE SHALL BE REINFORCED CONCRETE PIPE CONFORMING TO ASTM SPECIFICATION C-76 CL. IV.
- ALL MAN HOLE, CATCH BASIN, INLET, REAR YARD DRAINAGE STRUCTURES AND COVERS SHALL BE AS INDICATED ON THE PLANS AND CONSTRUCTED IN ACCORDANCE WITH MUNICIPALITY STANDARDS.
- INSTALL TRAPS ON THE FIRST CATCH BASIN (TYPICALLY A 4" DIAMETER STRUCTURE WITH 2' SLUMP) THAT IS UPSTREAM OF ITS CONNECTION TO A MAINLINE STORM OR SEWER MANHOLE, TO CAPTURE FLOATABLES AND TO MINIMIZE ESCAPE OF ODOUR.
- THE CONTRACTOR SHALL NOTIFY MISS DIG (1-800-482-7171) A MINIMUM OF THREE (3) WORKING DAYS PRIOR TO THE START OF CONSTRUCTION.
- EXACT GRADES AND INVERTS OF PROPOSED STORM SEWER ARE TO BE CHECKED WITH THE FIELD ENGINEER PRIOR AND DURING INSTALLATION. THE CONTRACTOR SHALL IMMEDIATELY NOTIFY THE DESIGN ENGINEER OF ANY PLAN INCONSISTENCY AND/OR UTILITY CONFLICTS.
- ALL STORM SEWER PIPE JOINTS SHALL BE "PREMIUM JOINT" MODIFIED GROOVED TONGUE (M.G.T.) WITH SYNTHETIC RUBBER GASKETS CONFORMING TO ASTM SPECIFICATION C-443 & C-361, UNLESS OTHERWISE INDICATED ON THE PLANS.
- FACILITY MANUFACTURED PRECAST TEE SECTIONS SHALL BE FOR ROOF DRAINS AND/OR SLUMP PUMP LEADS AND LATERALS WHERE INDICATED ON THE PLANS. BLIND TOP CONNECTIONS INTO STORM SEWER WILL NOT BE PERMITTED BY BREAKING PIPE WALL.
- THE CONTRACTOR SHALL PAY FOR AND SECURE ALL NECESSARY PERMITS AND LIKEWISE ARRANGE FOR ALL SITE INSPECTIONS.

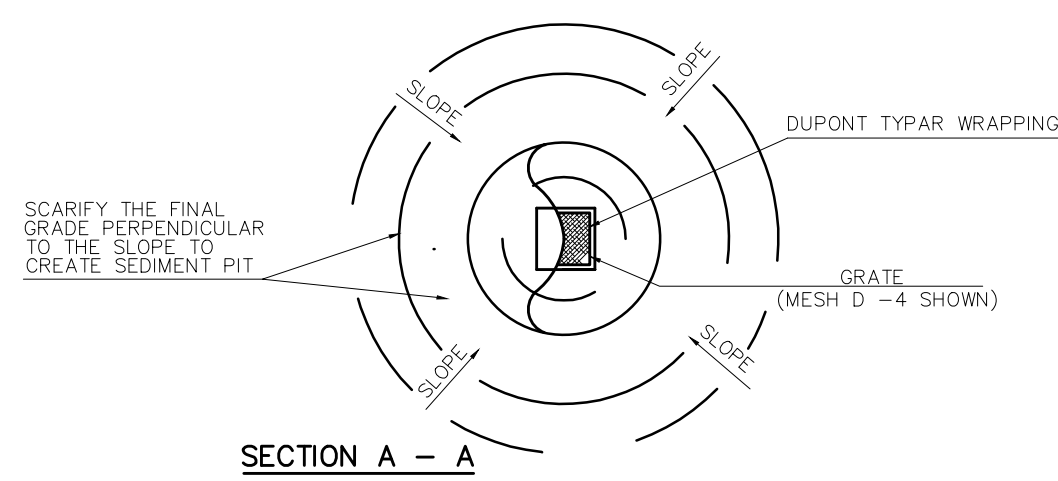

**LOW POINT INLET FILTER & SEDIMENT PIT DETAIL**  
N.T.S.

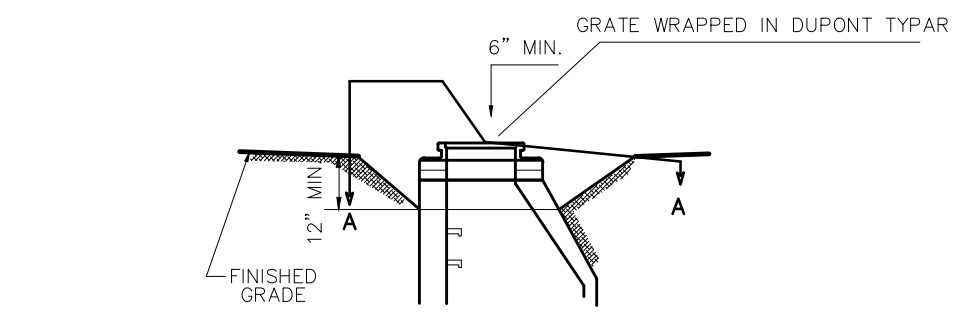

**STANDARD SEWER OR STORM CROSSING**  
N.T.S.

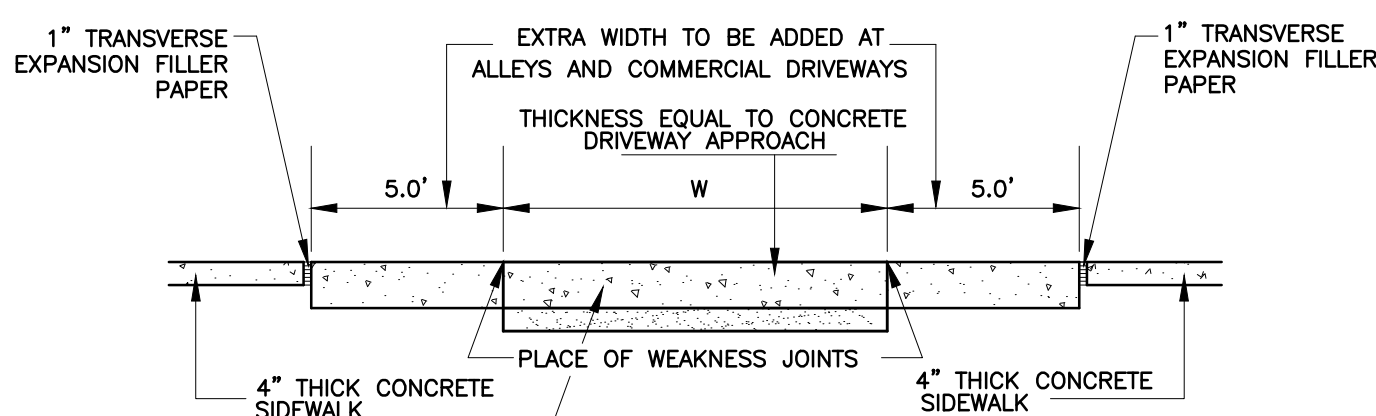

**THICKENED CONCRETE SIDEWALK (PLAIN)**  
N.T.S.

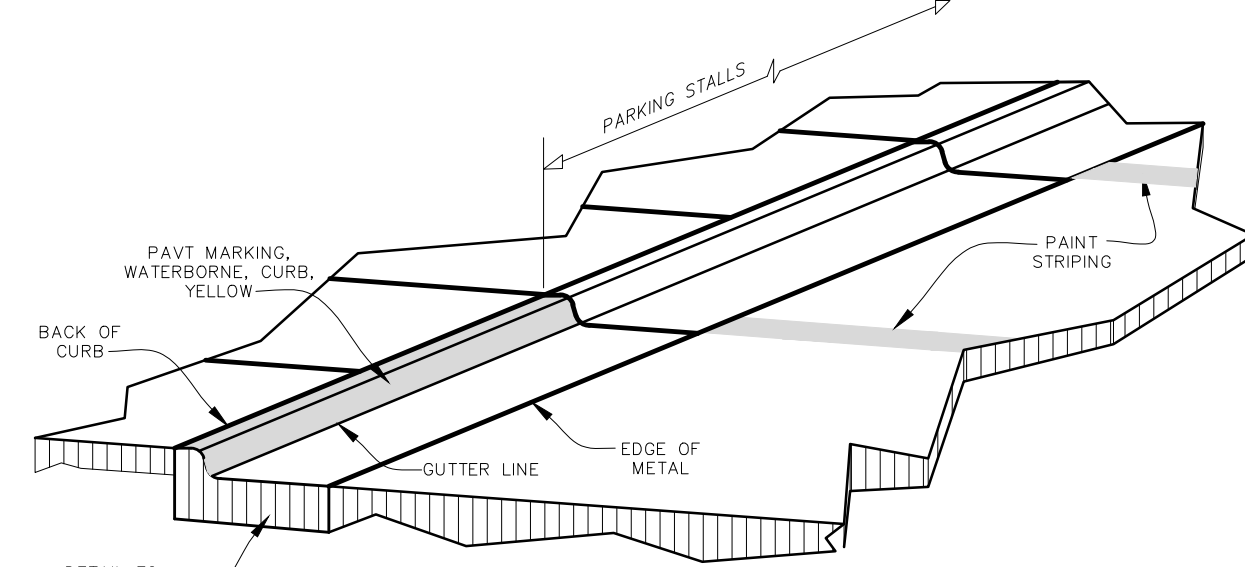

**CURB PAINT DETAIL**  
N.T.S.

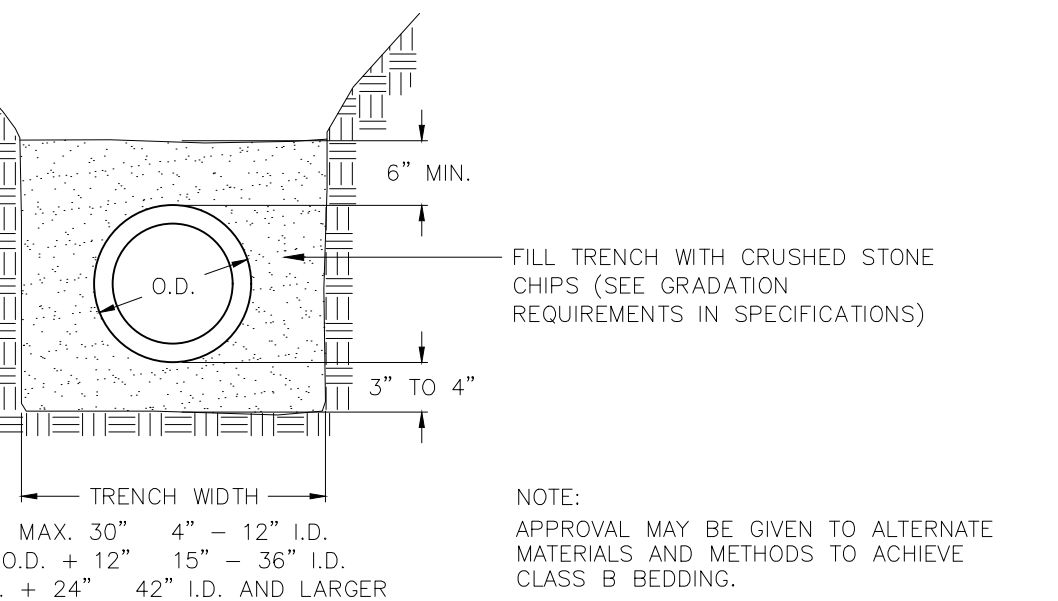

**STANDARD PIPE BEDDING**  
N.T.S.

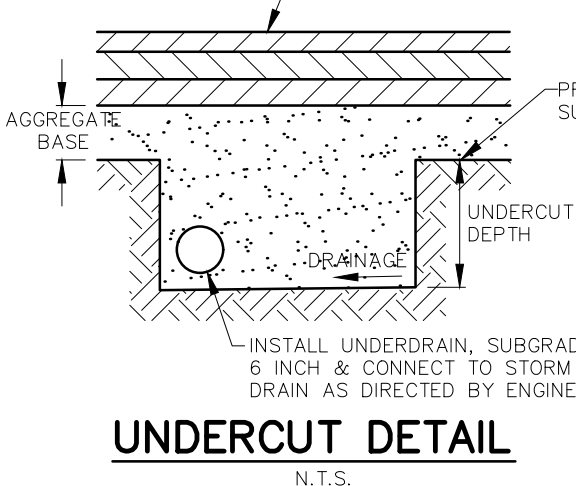

**UNDERCUT DETAIL**  
N.T.S.

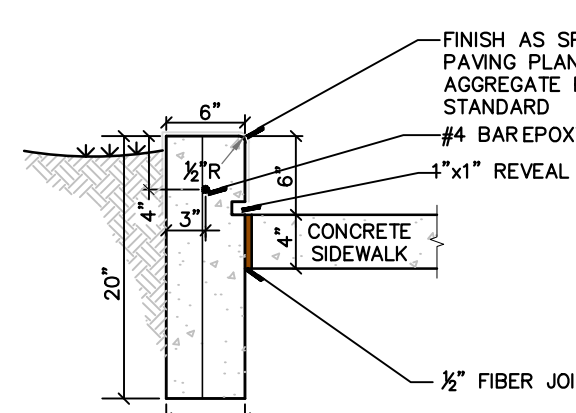

**20" HGT. PLANTER CURB DETAIL**  
N.T.S.

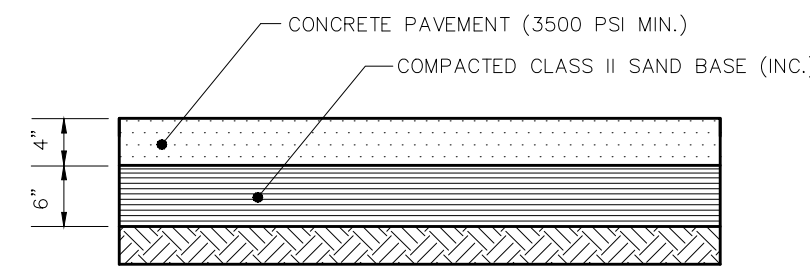

**4" CONCRETE SIDEWALK SECTION**  
STANDARD SIDEWALK REPLACEMENTS/INSTALLATIONS N.T.S.

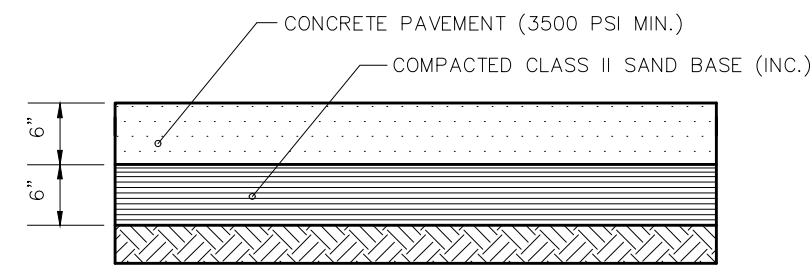

**6" CONCRETE SIDEWALK SECTION**  
TO MATCH SPECIFIED PAVEMENT THICKNESS THROUGH DRIVE APPROACH N.T.S.

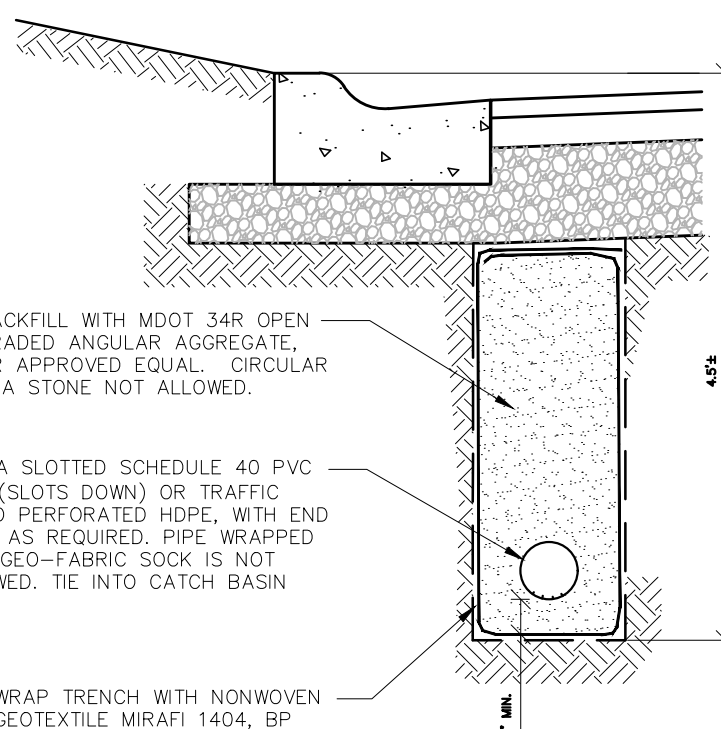

**6" PERFORATED PIPE UNDERDRAIN DETAIL**  
N.T.S.

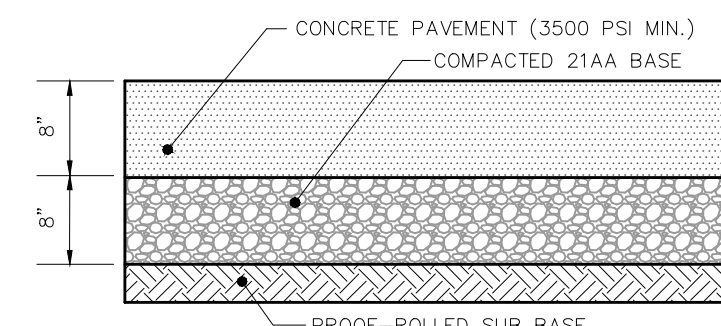

**TYPICAL 8" CONCRETE SIDEWALK**  
FOR USE IN STANDARD SIDEWALK IN WILLYTS ALLEY APPROACH AND SIDEWALK RAMP/ CONCRETE BASE IN N.W. & S.E. CORNERS OF MAPLE INTERSECTION N.T.S.

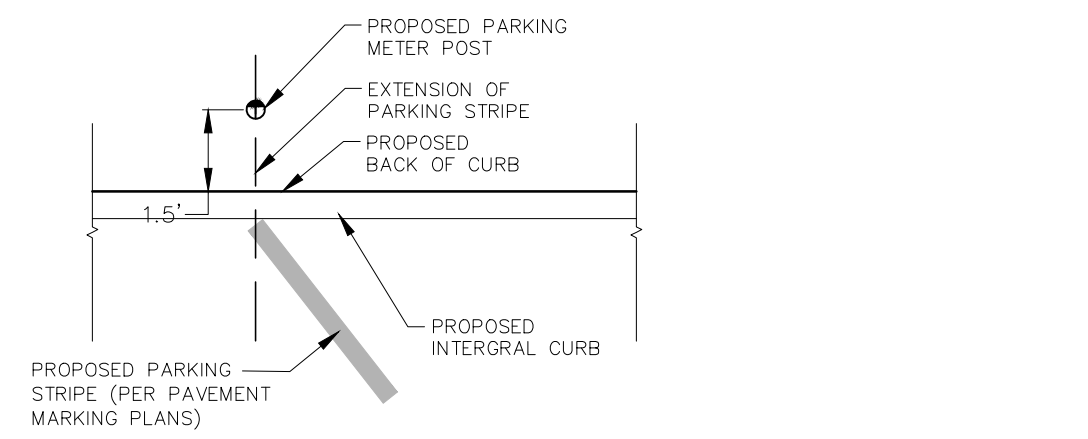

**PLAN VIEW**

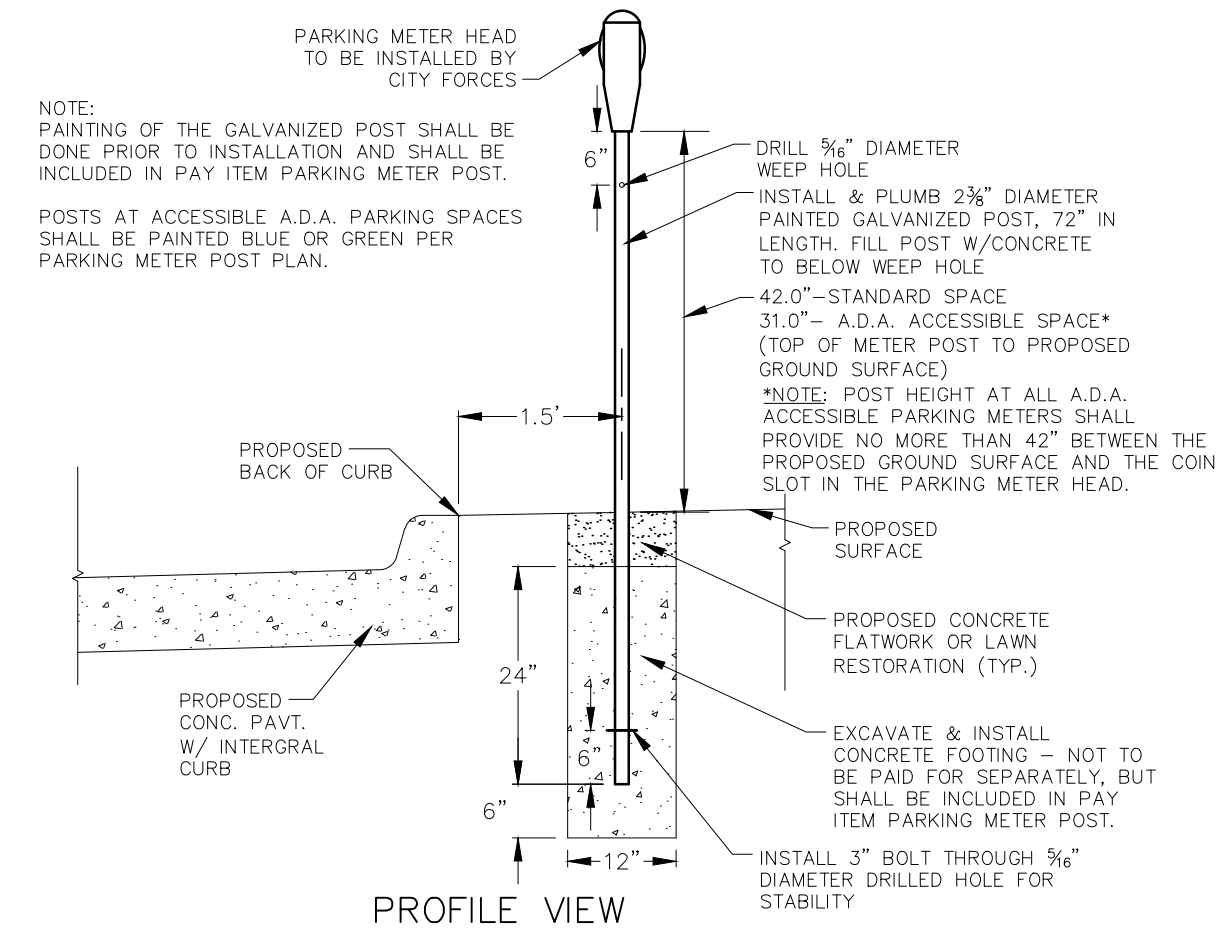

**PARKING METER POST**  
N.T.S.

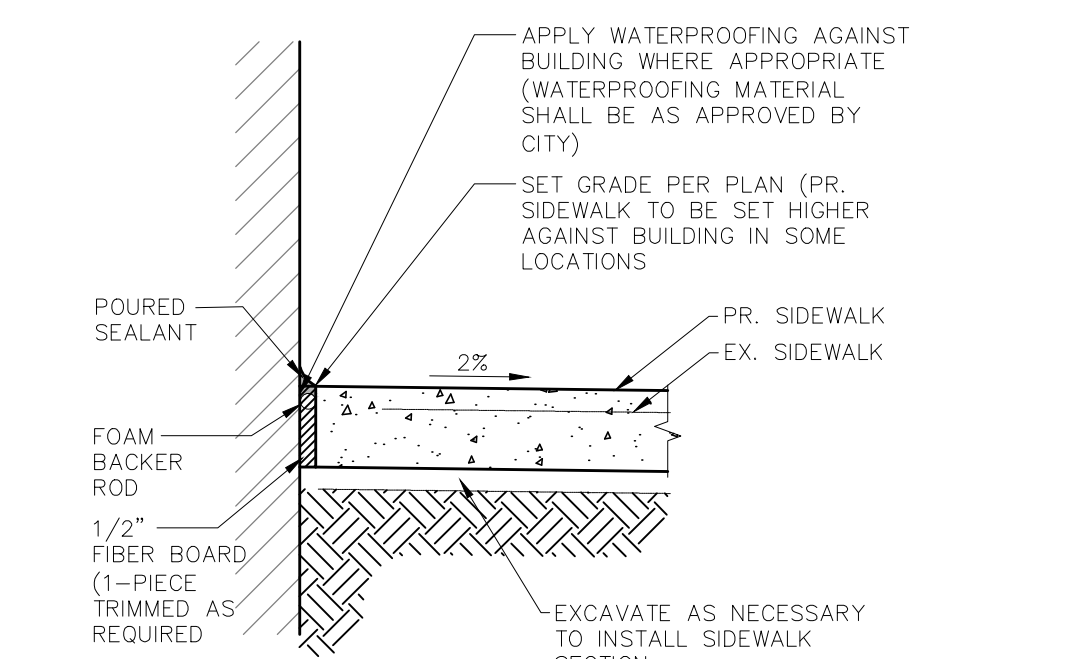

**JOINT DETAIL AT BUILDING**  
N.T.S.

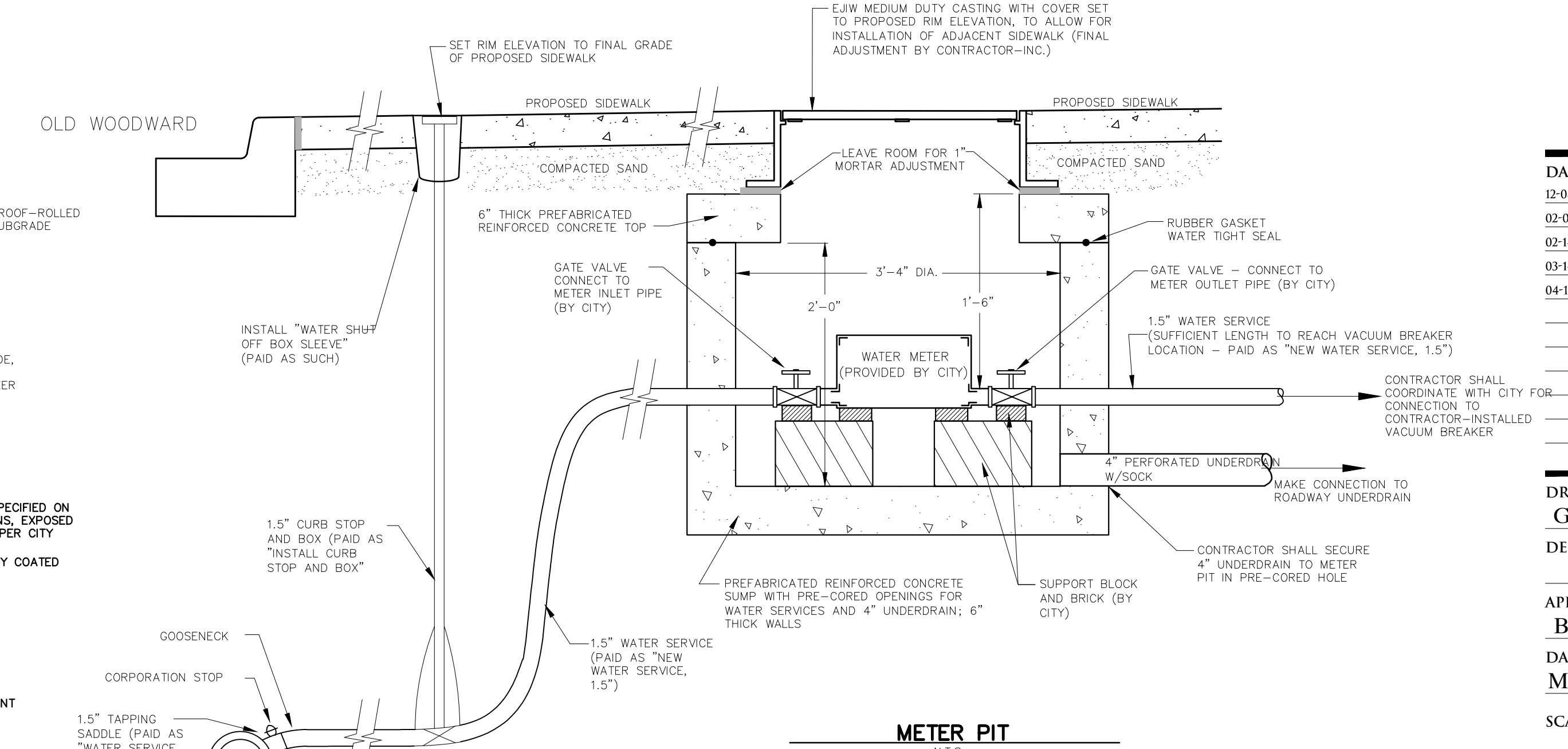

**METER PIT**  
N.T.S.

SEAL

PROJECT  
Brown Street Paving Project  
Contract # 5-23(P)

CLIENT



Engineering Department  
151 Martin Street  
Birmingham, MI 48012

PROJECT LOCATION  
Part of the Northeast 1/4  
of Section 36  
Town 2 North,  
Range 10 East  
City of Birmingham,  
Oakland County, Michigan

SHEET  
Notes & Details (1 of 2)



DATE	ISSUED/REVISED
12-08-22	ISSUED SURVEY
02-04-23	CONCEPT PLAN
02-14-23	UPDATED CONCEPT PLAN
03-16-23	90% CITY REVIEW
04-10-23	RIDS

DRAWN BY:  
G. Viju

DESIGNED BY:

APPROVED BY:  
B. Buchholz

DATE:  
March 16, 2023

SCALE: N.T.S.

SEAL

PROJECT  
Brown Street Paving Project  
Contract # 5-23(P)

CLIENT



Engineering Department  
151 Martin Street  
Birmingham, MI 48012

PROJECT LOCATION

Part of the Northeast 1/4  
of Section 36  
Town 2 North,  
Range 10 East  
City of Birmingham,  
Oakland County, Michigan

SHEET  
Notes & Details (2 of 2)



Know what's below  
Call before you dig.

DATE	ISSUED/REVISED
12-08-22	ISSUED SURVEY
02-04-23	CONCEPT PLAN
02-14-23	UPDATED CONCEPT PLAN
03-16-23	90% CITY REVIEW
04-10-23	BIDS

DRAWN BY:  
G. Viju

DESIGNED BY:

APPROVED BY:  
B. Buchholz

DATE:  
March 16, 2023

SCALE: N.T.S.

NFE JOB NO. SHEET NO.  
D162-01 C14

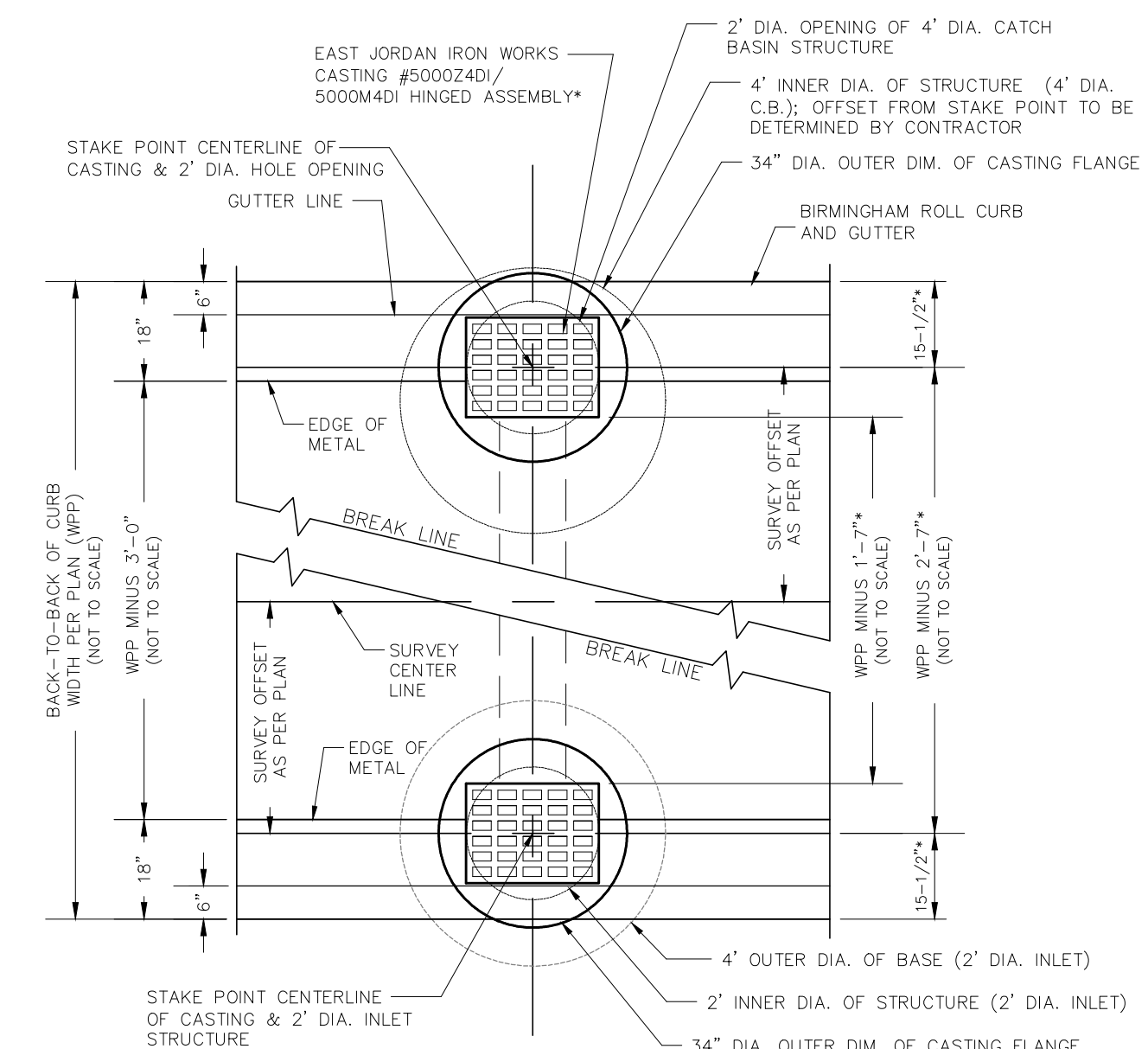
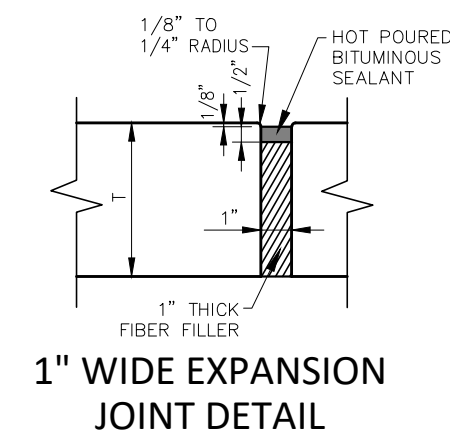
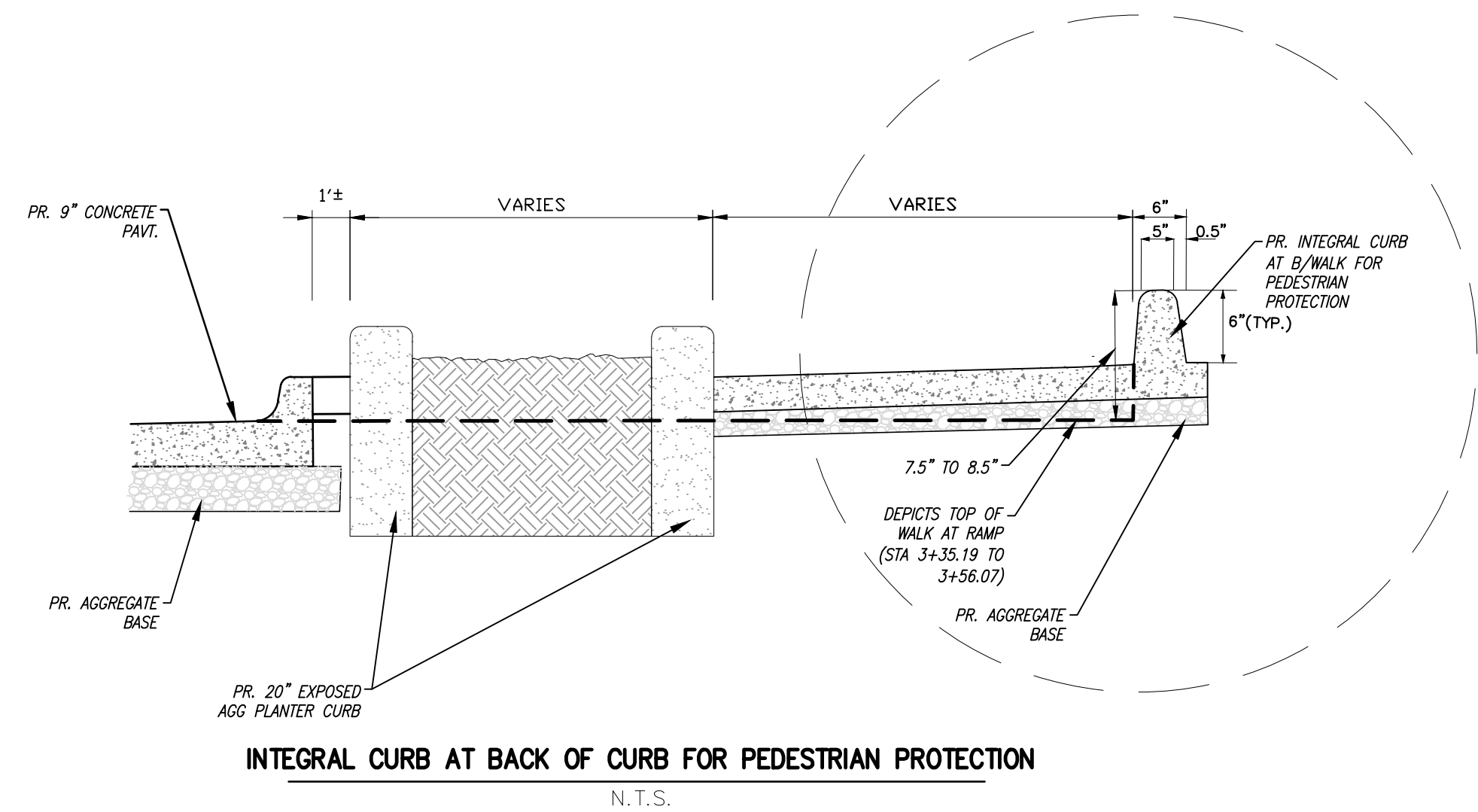

\*CONTRACTOR RESPONSIBLE FOR CORRECT ALIGNMENT OF STRUCTURE, CASTING AND CURB AS SPECIFIED, UNLESS OTHERWISE DIRECTED BY CITY.

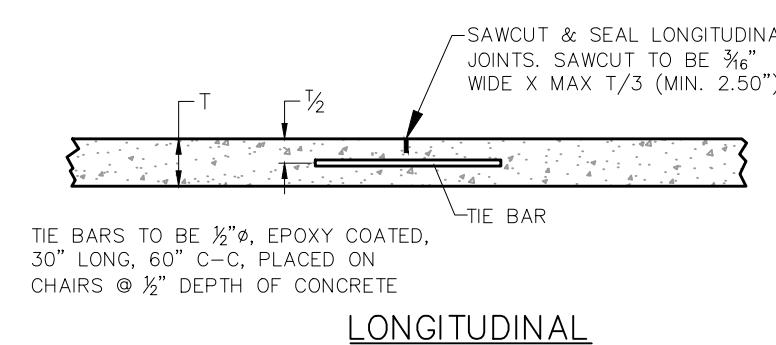
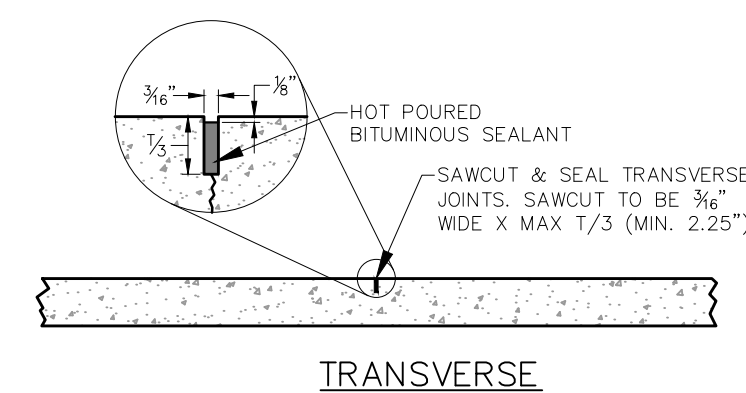
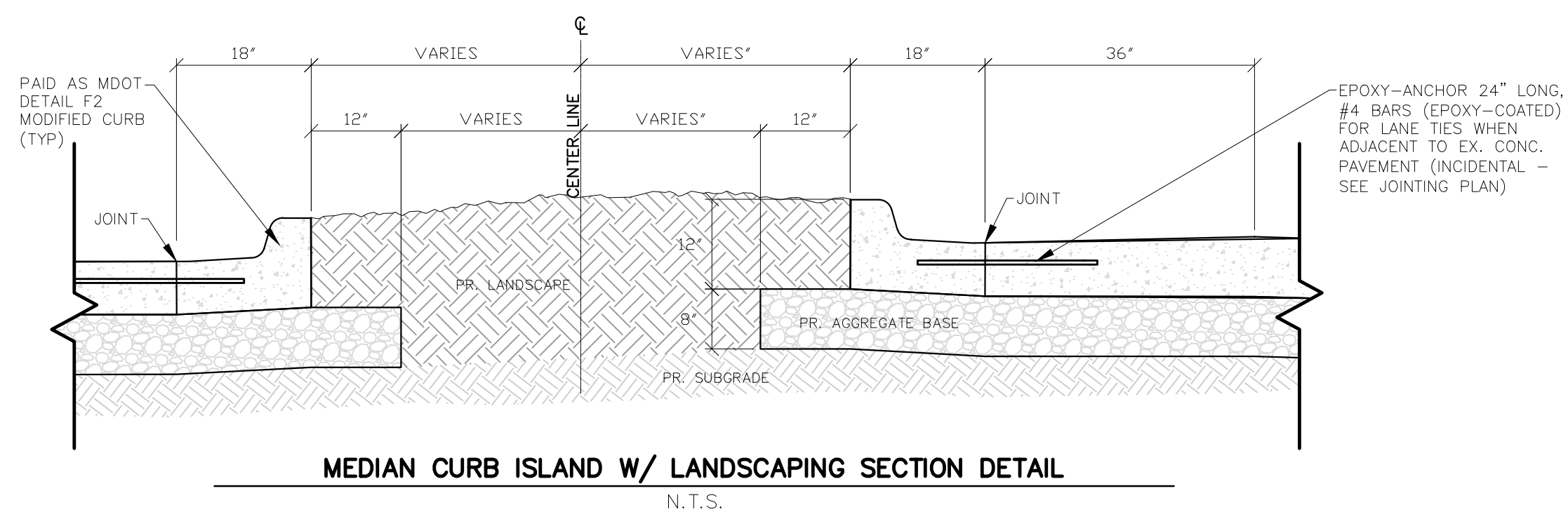

6 CONTRACTION JOINT

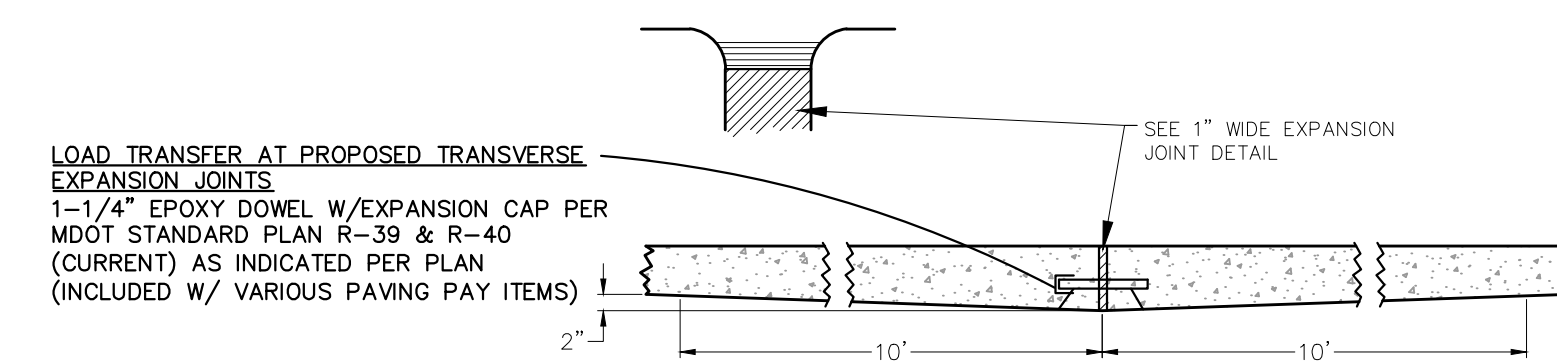

8 EXPANSION JOINT

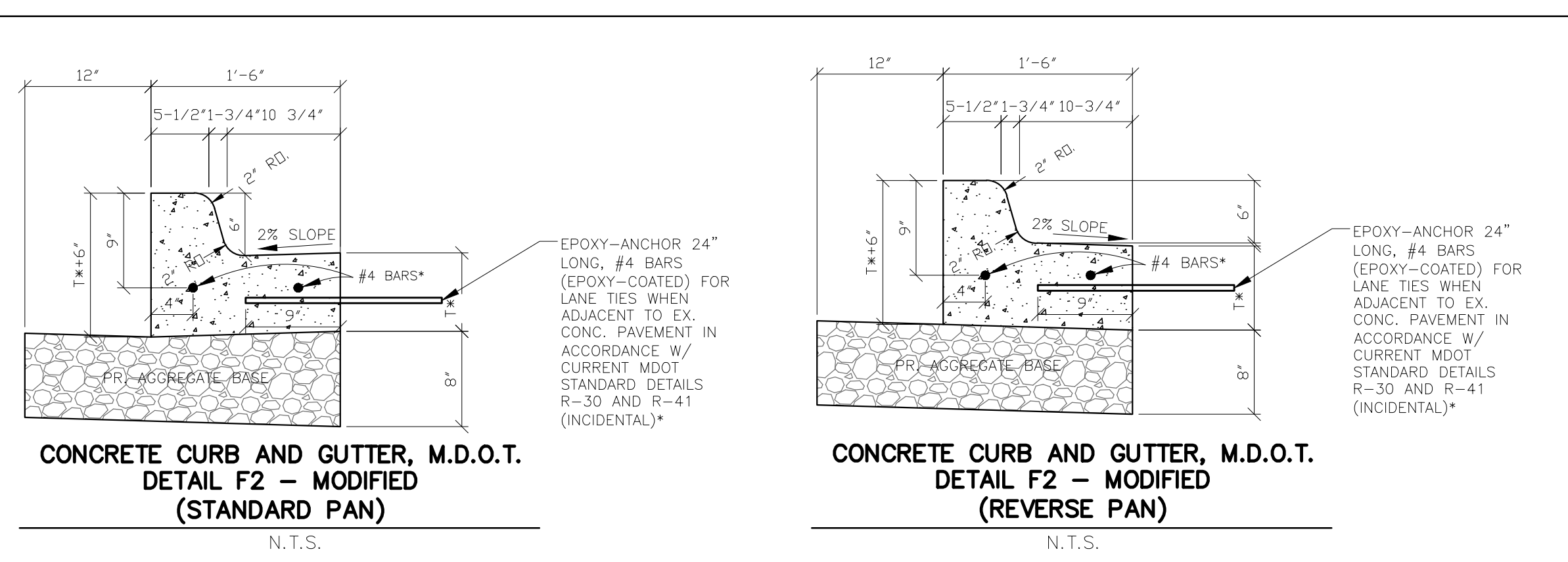

- NOTES:**
- "T" IS EQUAL TO THE THICKNESS & SLOPE IS EQUAL TO THE CROSS-SLOPE OF THE CONCRETE PAVEMENT WHEN CURB & GUTTER IS POURED INTEGRAL TO THE PAVEMENT.
  - OMIT #4 LONGITUDINAL EPOXY COATED BARS WHEN CURB & GUTTER IS POURED INTEGRAL OR TIED TO A NON-REINFORCED CONCRETE PAVEMENT.
  - PROPOSED CURB HEIGHTS INDICATED ARE TYPICAL, AND VARY WHERE INDICATED ON PLAN. CURB HEIGHTS SHALL MATCH EXISTING AT REPAIR LIMITS.
  - PROVIDE COMPACTED 21AA CRUSHED LESTONE AGGREGATE BASE UNDER CURB & GUTTER AND WITHIN 12" MINIMUM BEYOND BACK OF CURB; THICKNESS TO MATCH AGGREGATE BASE LAYER THICKNESS OF ADJACENT PROPOSED PAVEMENT.
  - OMIT 24" LONG #4 EPOXY COATED BARS WHEN CURB & GUTTER IS POURED INTREGAL OR TIED TO A NON-REINFORCED CONCRETE PAVEMENT.

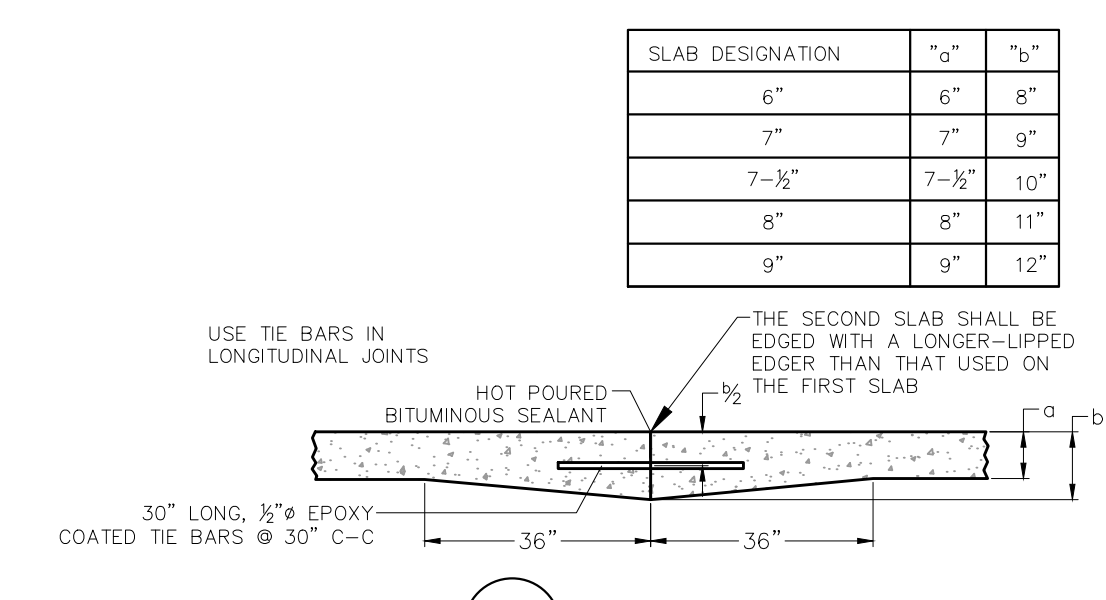
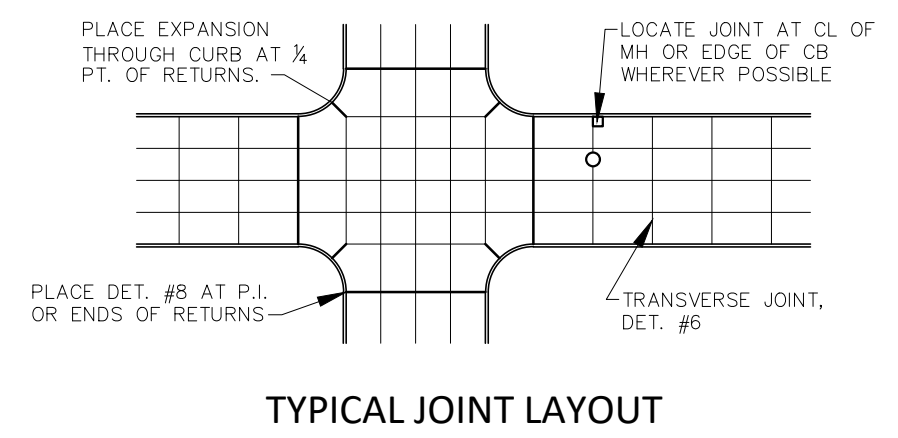

5 CONSTRUCTION JOINT

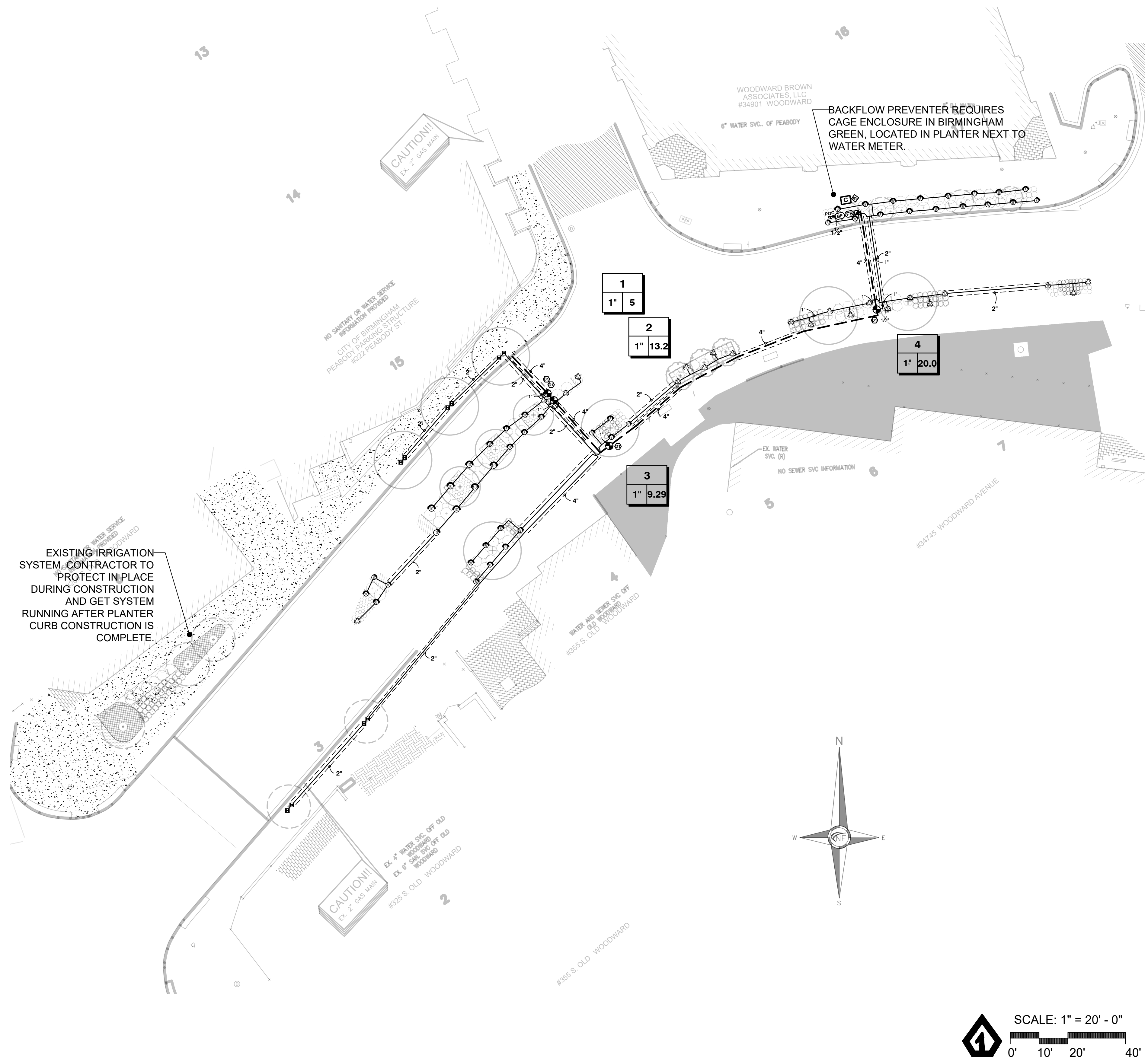

## IRRIGATION SCHEDULE

SYMBOL	MANUFACTURER/MODEL	QTY
EST RCS CST SST	Rain Bird 1812 15 Strip Series	21
O T H F	Rain Bird 1812 8 Series MPR	38
O T H F	Rain Bird 1812 10 Series MPR	7
1401 1402 1404 1408	Rain Bird 1804-1400 Flood	10
SYMBOL	MANUFACTURER/MODEL	QTY
☐	Rain Bird PGA Globe 1"	4
☐	Hunter HQ-44RC 1"	1
☐	Febco 825Y w/Cage enclosure 1"	1
☐	Rain Master EGP-TW-S	1
☐	Irritrol RS1000	1
☐	Rain Master TW-D-1	4
☐	Irritrol FS-B150	1
☐	Point of Connection 1"	1
—	Irrigation Lateral Line: Polyethylene Pipe 100 PSI 1"	935.5 l.f.
—	Irrigation Lateral Line: Polyethylene Pipe 100 PSI 1 1/2"	4.5 l.f.
—	Irrigation Mainline: PVC Class 160 SDR 26 1 1/2"	201.7 l.f.
—	Pipe Sleeve: PVC Class 160 SDR 26 2"	277.9 l.f.
—	Pipe Sleeve: PVC Class 160 SDR 26 4"	144.6 l.f.

Valve Callout

# Valve Number

# Valve Flow

# Valve Size

## IRRIGATION SPECIFICATIONS

- IRRIGATION SYSTEM DESIGN BASED ON 20 GPM AT 50 PSI.
- IRRIGATION DESIGN IS FROM THE POINT OF CONNECTION(POC) ONLY. THE DESIGN IS BASED ON GALLONS PER MINUTE(GPM) AND POUNDS PER SQUARE INCH(PHI) FURNISHED BY OTHERS.
- IRRIGATION CONTRACTOR IS TO VERIFY POINT OF CONNECTION IN THE FIELD. INSTALLER IS TO CONFIRM THE MINIMUM DISCHARGE REQUIREMENTS OF THE POINT OF CONNECTION AS INDICATED ON THE LEGEND PRIOR TO INSTALLATION.
- THE PRESSURE REQUIREMENT AT THE POINT OF CONNECTION IS BASED ON NO MORE THAN 5 FEET OF ELEVATION CHANGE IN THE AREAS OF IRRIGATION.
- ALL PRODUCTS SHALL BE INSTALLED IN ACCORDANCE WITH THE MANUFACTURER'S RECOMMENDATIONS AND ACCORDING TO LOCAL BUILDING, ELECTRICAL, AND PLUMBING CODES.
- IRRIGATION CONTRACTOR WILL ARRANGE INSPECTIONS REQUIRED BY LOCAL AGENCIES AND ORDINANCES DURING THE COURSE OF CONSTRUCTION AS REQUIRED. ALL WIRING TO BE PER LOCAL CODE. BACKFLOW PREVENTION TO BE PER LOCAL CODE.
- LOCATION OF IRRIGATION COMPONENTS SHOWN ON DRAWING IS APPROXIMATE. ACTUAL PLACEMENT MAY VARY SLIGHTLY AS REQUIRED TO ACHIEVE FULL, EVEN COVERAGE.
- ALL SPRINKLER HEADS SHALL BE INSTALLED PERPENDICULAR TO FINISH GRADES. EXCEPT AS OTHERWISE INDICATED.
- INSTALL IRRIGATION MAINS WITH A MINIMUM 18" OF COVER BASED ON FINISH GRADES. INSTALL IRRIGATION LATERALS WITH MINIMUM 12" OF COVER BASED ON FINISH GRADES.
- PIPE LOCATIONS ARE DIAGRAMMATIC. VALVES AND MAINLINE SHOWN IN PAVED AREAS ARE FOR GRAPHIC CLARITY ONLY.
- THE IRRIGATION CONTRACTOR SHALL COMPLY WITH PIPE SIZES AS INDICATED.
- ALL WIRE SPLICES OR CONNECTIONS SHALL BE MADE WITH APPROVED WATERPROOF WIRE CONNECTIONS AND BE IN A VALVE OR SPLICE BOX.
- ALL CONTROL WIRING DOWNSTREAM OF THE CONTROLLER IS TO BE 2-WIRE, UL APPROVED DIRECT BURY.
- THE DESIGN IS BASED ON THE SITE INFORMATION AND/OR DRAWING SUPPLIED WITH THE DESIGN CRITERIA BEING SET (AREA TO BE IRRIGATED, EQUIPMENT MANUFACTURER AND MODEL TO BE USED, WATER SOURCE INFORMATION, ELECTRICAL POWER AVAILABILITY, ETC...). SITEONE LANDSCAPE SUPPLY BEARS NO RESPONSIBILITY OR LIABILITY FOR ANY ERRORS IN DESIGN OR INSTALLATION THAT ARISE DUE TO INACCURACIES IN THE ABOVE REFERENCED INFORMATION SUPPLIED TO SITEONE LANDSCAPE SUPPLY LANDSCAPES IN RELATION TO THIS PROJECT, UNLESS OTHERWISE NOTED.

## CONSTRUCTION DOCUMENTS

Issued for Construction

revision	date	issued
△	03.16.2023	90% City Review
△	04.10.2023	BIDS
△		
△		
△		
△		
△		
△		
△	XX.XX.XXXX	SET NAME

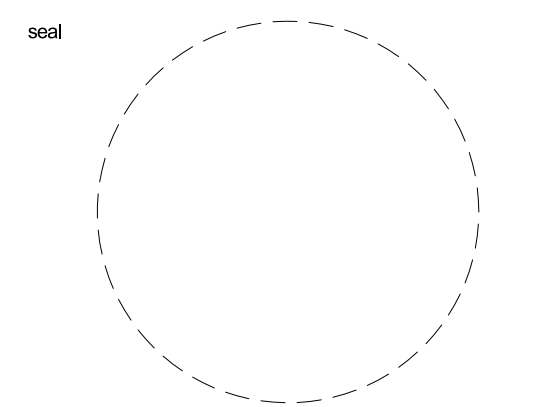

issue date  
03.XX.2023

project number  
dXXXXX

sheet name  
**IRRIGATION DESIGN**

sheet number  
**IR 1.0**



Project Services

1-800-347-4272  
http://www.projectsolutions.siteone.com

650 Stephenson Highway  
Troy, Michigan 48063  
Phone 248.588.2100  
Fax 248.588.3528  
www.Siteone.com  
800.347.4272  
Project Services Number: 316242

**BROWN STREET**  
BIRMINGHAM, MI 48009  
Design Date: 03/03/23  
Revision Date: 03/16/23, 03/24/23, 04/07/23  
Drawn By: SW  
Checked By: C. BEST

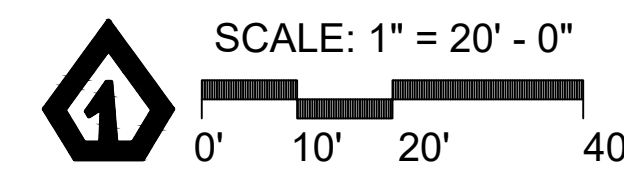

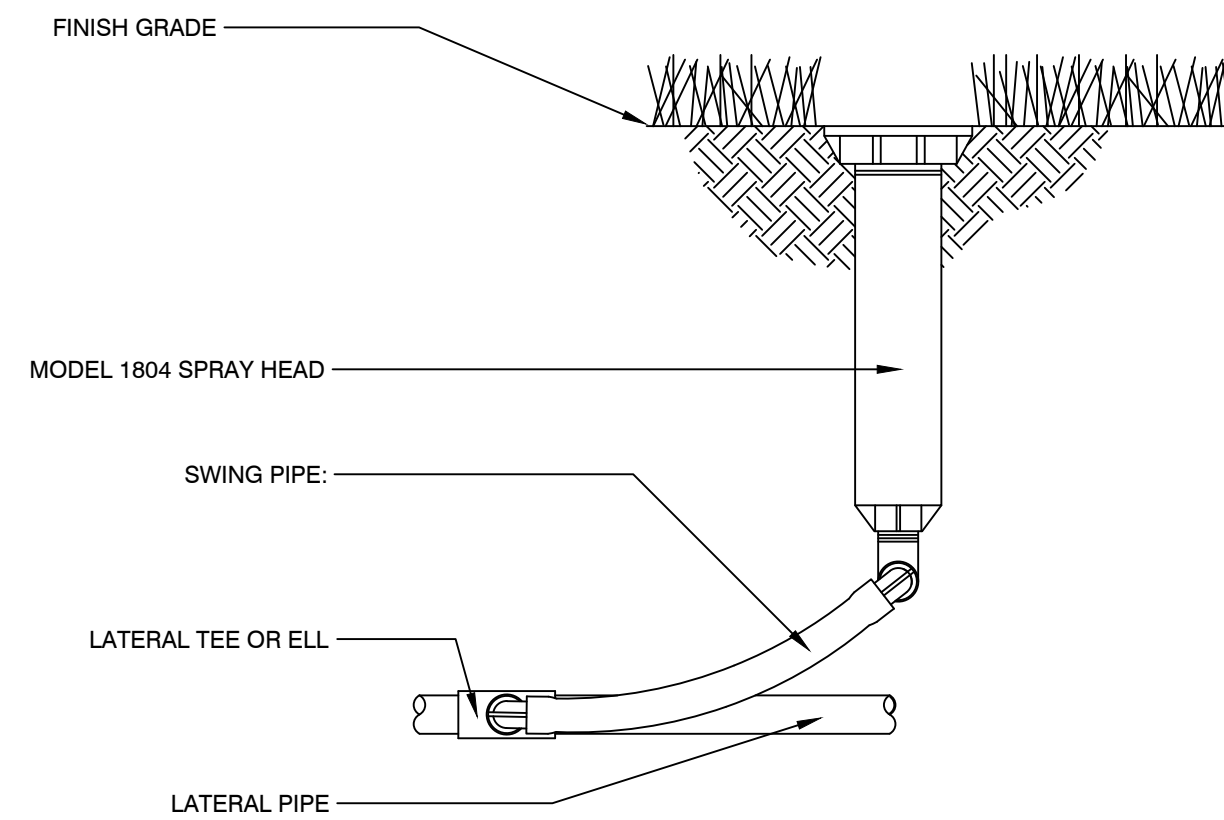

**1** 1804 SPRAY HEAD WITH SWING PIPE  
 S1-SP-RAI-01

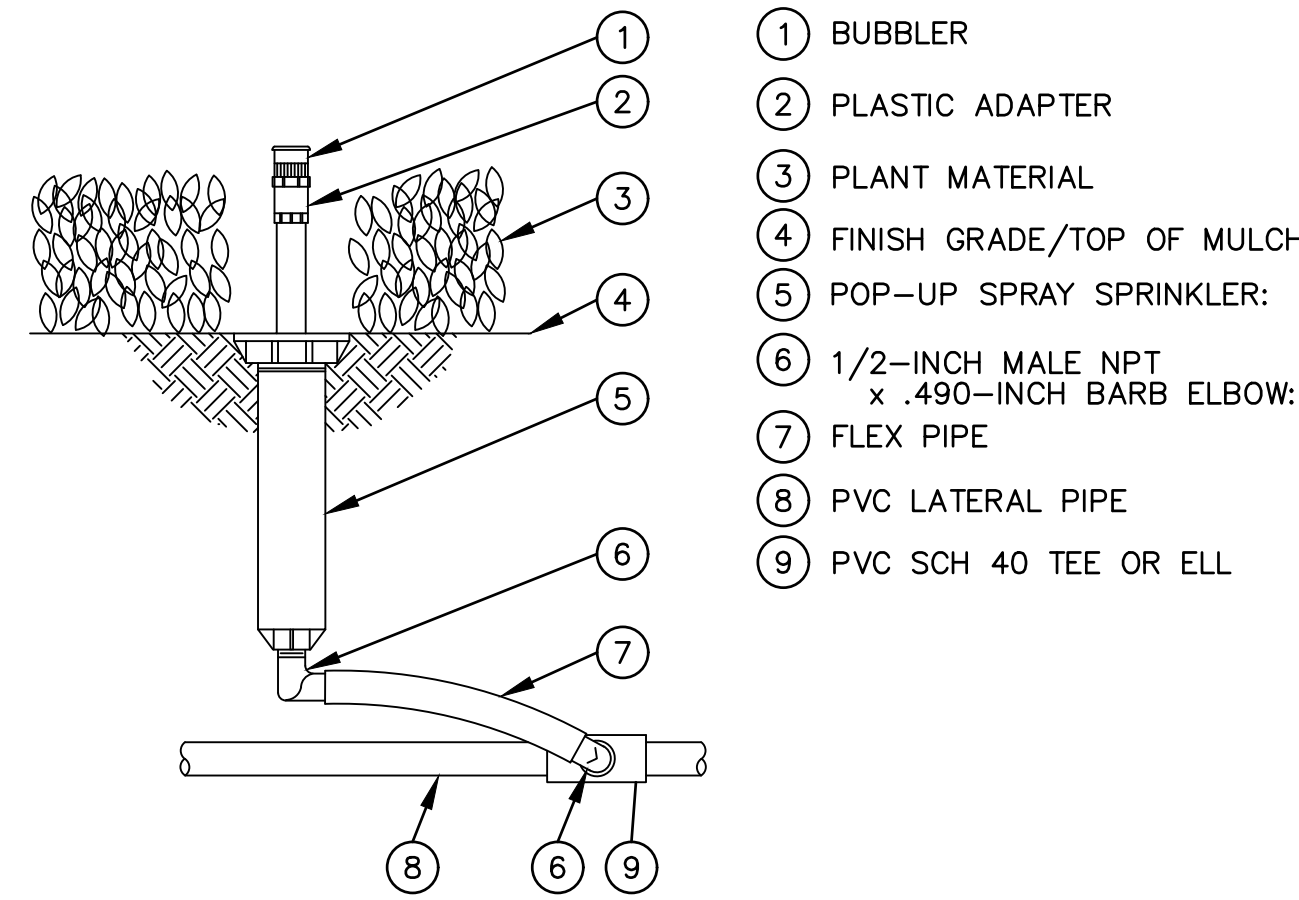

**2** BUBBLER ON POP-UP SPARYHEAD  
 NTS

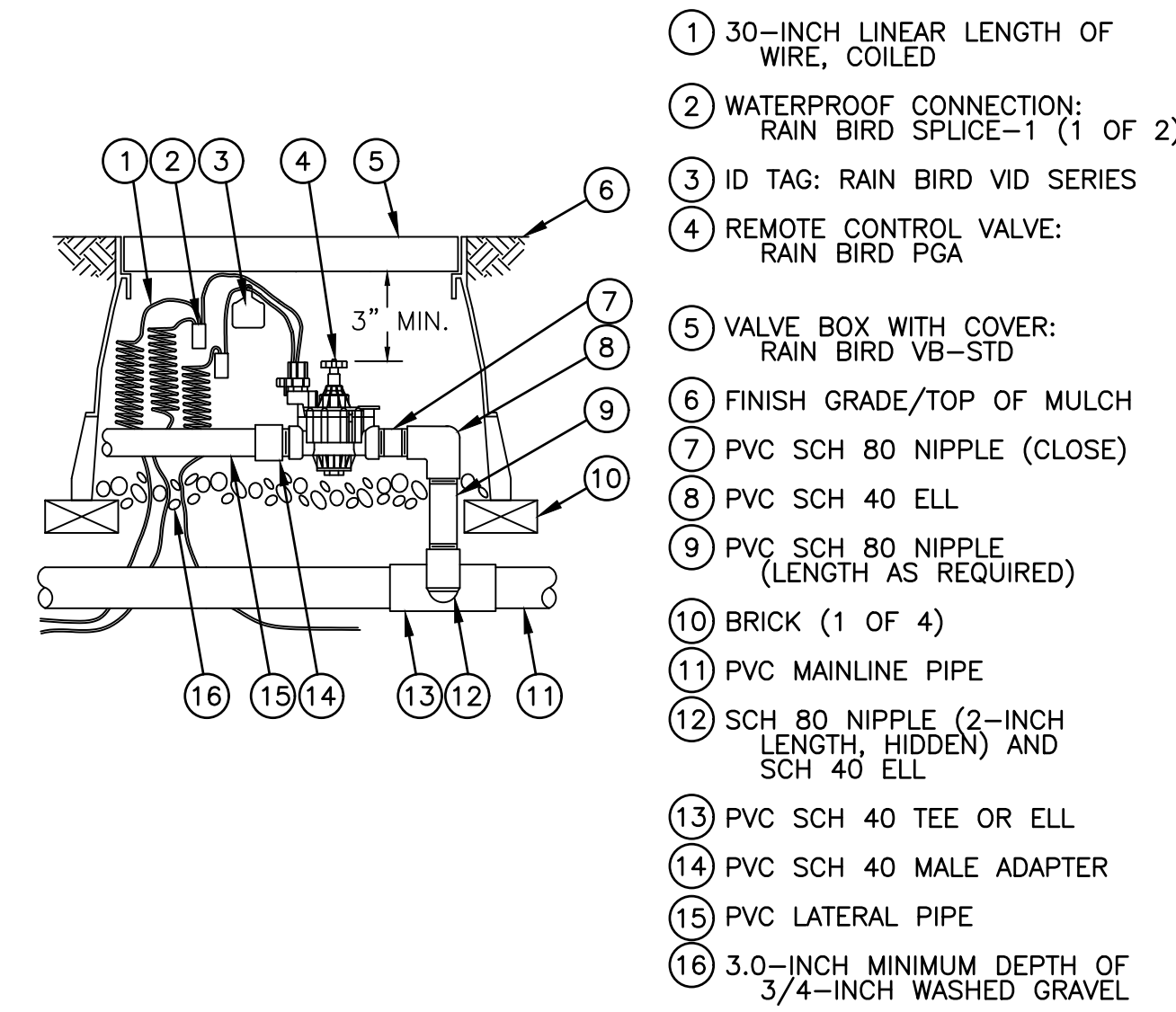

**3** PGA SERIES ELECTRIC VALVE  
 S1-VA-RAI-02

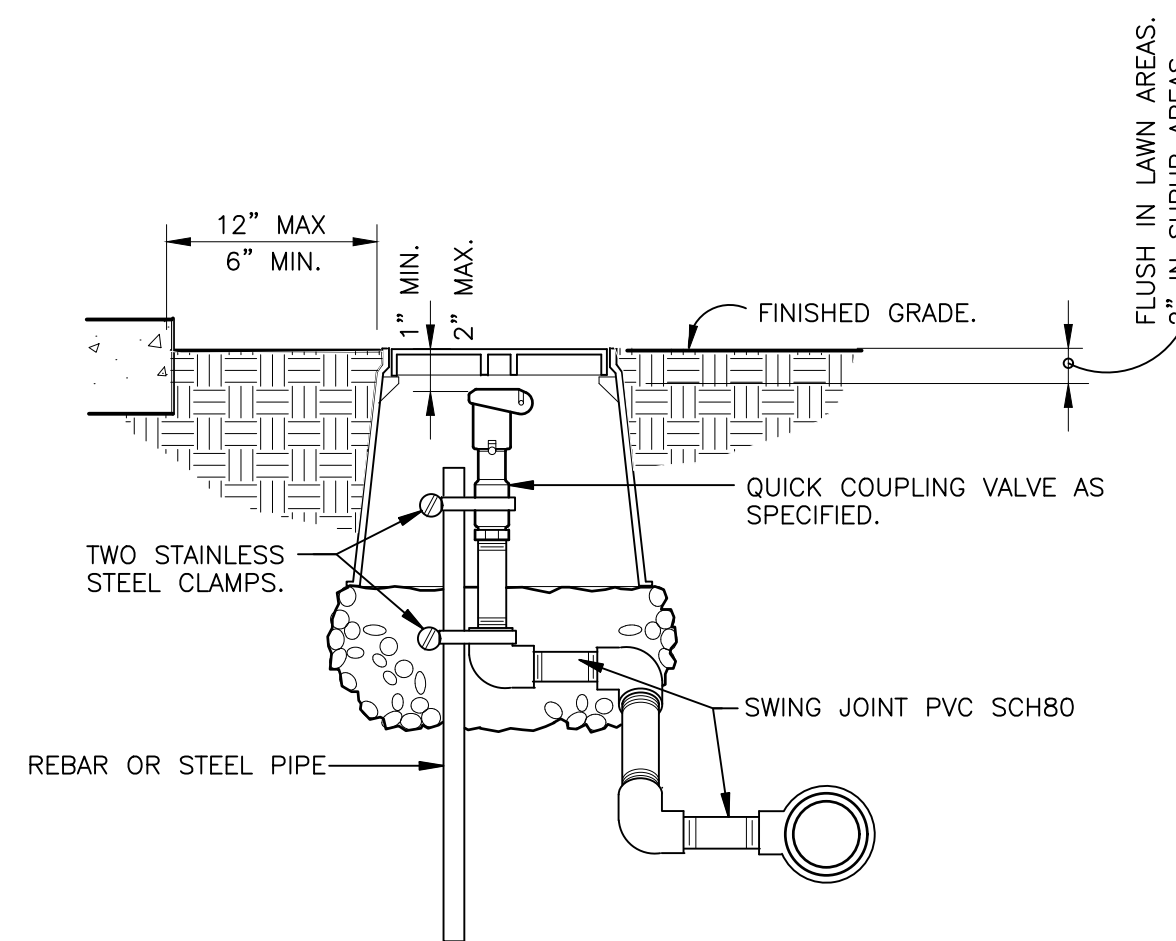

**4** QUICK COUPLING VALVE IN BOX  
 S1-QU-01

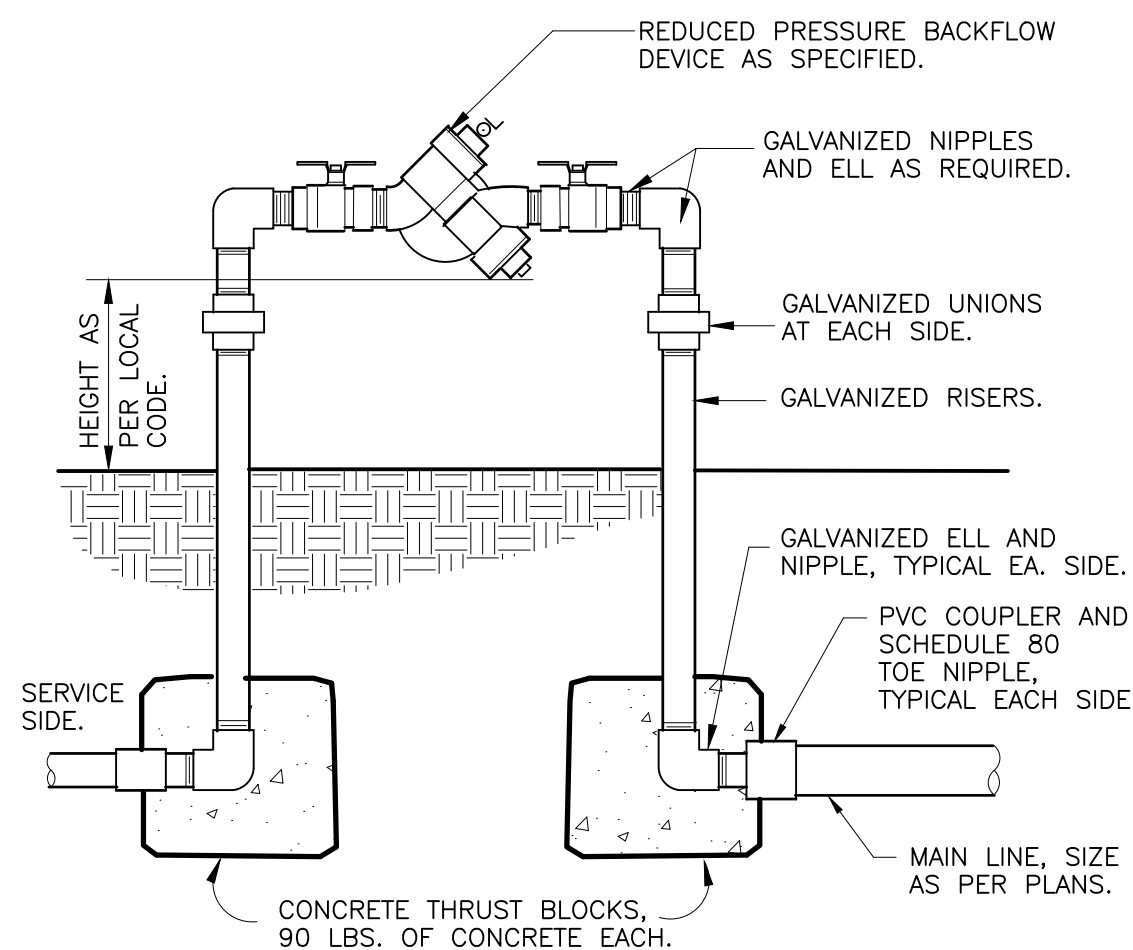

**5** REDUCED PRESSURE BACKFLOW DEVICE  
 1" = 1'-0"  
 FX-IR-FX-BACK-03

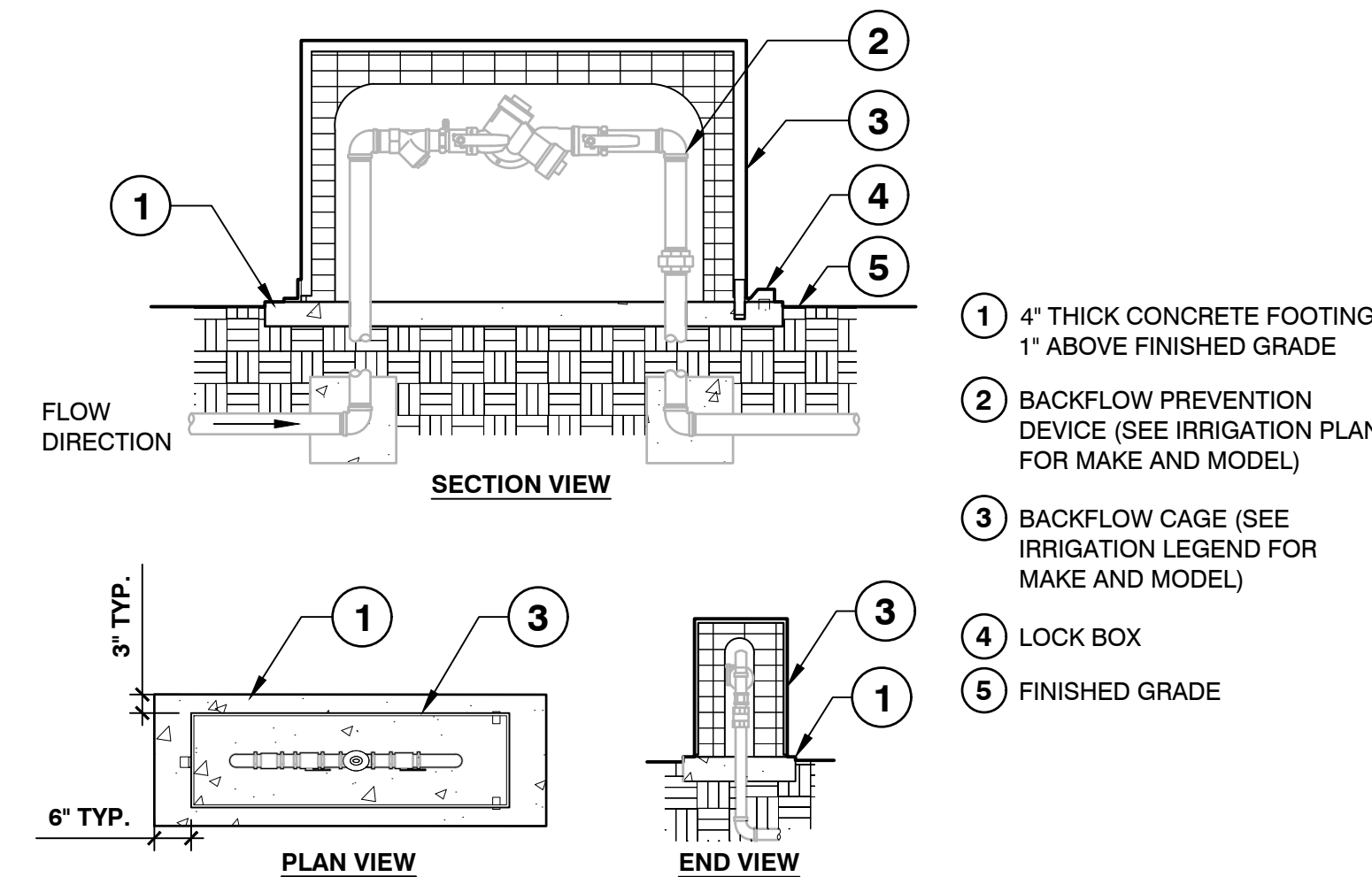

**6** BACKFLOW CAGE  
 3/8" = 1'-0"  
 FX-IR-FX-BACK-01

- NOTES:
1. INSTALL BACKFLOW CAGE PER MANUFACTURER'S SPECIFICATIONS AND RECOMMENDATIONS.
  2. SEE BACKFLOW PREVENTION DEVICE DETAIL FOR REFERENCE.
  3. LOCK BOX SHALL BE LOCATED ABOVE CONCRETE FOOTING
  4. CONTRACTOR SHALL PROVIDE A LOCK AS APPROVED BY THE OWNER'S REPRESENTATIVE.

**CONSTRUCTION DOCUMENTS**  
 Issued for Construction

revision	date	issued
△	03.16.2023	90% City Review
△	04.10.2023	BIDS
△		
△		
△		
△		
△		
△		
△		
△	XX.XX.XXXX	SET NAME

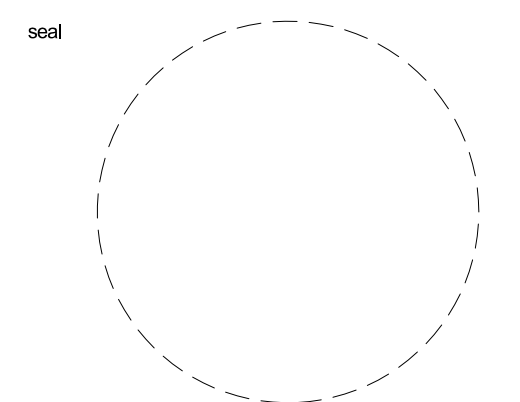

issue date  
 03.XX.2023

project number  
 dXXXXX

sheet name

**IRRIGATION DETAILS**

sheet number

**IR 1.1**



1-800-347-4272  
<http://www.projectsolutions.siteone.com>

650 Stephenson Highway  
 Troy, Michigan 48063  
 Phone 248.588.2100  
 Fax 248.588.3528  
 www.Siteone.com  
 800.347.4272  
 Project Services Number: 316242

**BROWN STREET**  
 BIRMINGHAM, MI 48009  
 Design Date: 03/03/23  
 Revision Date: 03/16/23, 03/24/23  
 04/07/23  
 Drawn By: SW  
 Checked By: C. BEST







**CODED NOTES:**

- ① PROPOSED 4'X4' STEEL TREE GRATE FRAME. REFER TO CIVIL SET FOR DETAILS
- ② PROTECT EXISTING BLACK-EYED SUSAN IN PLACE UNDER TREE CANOPY. LANDSCAPE ARCHITECT TO STAKE LIMITS IN FIELD.
- ③ ANNUAL PLANTINGS BY OWNER
- ④ EXISTING CRABAPPLE TREES (3) TO REMAIN
- ⑤ EXISTING TREE TO REMAIN, PROTECT IN PLACE. SEE SPECIFICATIONS FOR DETAILS. ALL DEMOLITION AND CONSTRUCTION WITHIN 15' DIA. OF TRUNK TO BE DONE BY HAND.

**PLANT LIST - L1.1**

SYMBOL	QTY	BOTANICAL NAME	COMMON NAME	SIZE	ROOT	REMARK
<b>DECIDUOUS TREES</b>						
TI AM	3	TILIA AMERICANA 'MCKSENTRY'	AMERICAN SENTRY LINDEN	3.5' Cal.	B&B	MATCH FORM
UL AM	2	ULMUS AMERICANA 'PRINCETON'	PRINCETON ELM	3.5' Cal.	B&B	MATCH FORM
ZE SE	3	ZELKOVA SERRATA 'JFS-KW1'	CITY SPRITE ZELKOVA	3.5' Cal.	B&B	MATCH FORM
<b>PERENNIALS</b>						
GE RO	24	GERANIUM X ROZANNE'	ROZANNE GERANIUM	#1 CONT.		24" O.C.
PA TE	892	PACHYSANDRA TERMINALIS 'GREEN CARPET'	GREEN CARPET PACHYSANDRA	24/FLAT		6" O.C.
RU HI	18	RUDBECKIA HIRTA	LITTLE GOLDSTAR BLACK EYED SUSAN	#1 CONT.		
<b>GRASSES</b>						
PE AL	51	PENNISETUM ALOPECUROIDES 'LITTLE BUNNY'	LITTLE BUNNY FOUNTAIN GRASS	#2 CONT.		
SE AU	22	SESLERIA AUTUMNALIS	AUTUMN MOOR GRASS	#1 CONT.		
<b>SHRUBS</b>						
HY PA	19	HYDRANGEA PANICULATA 'JANE'	LITTLE LIME HYDRANGEA	#5 CONT.		
IL GL	6	ILEX GLABRA 'SHAMROCK'	SHAMROCK INKBERRY HOLLY	#3 CONT.		
PI MU	8	PINUS MUGO 'HONEYCOMB'	HONEYCOMB MUGO PINE	#3 CONT.		

**PLANTING LEGEND**

	ANNUALS (BY OWNER)
	PERENNIALS (MEDIAN) SEE DETAIL D, SHEET L1.3
	EXISTING BLACK-EYED SUSAN TO REMAIN
	GROUNDCOVER

**MKSK**

Planning  
Urban Design  
Landscape Architecture

4219 WOODWARD AVENUE, SUITE 305  
DETROIT, MICHIGAN 48201  
313.652.1101 MKSKSTUDIOS.COM

client / owner  
City of Birmingham  
project name  
**BROWN STREET  
PAVING PROJECT  
CONTRACT #5-23P**  
project address  
Birmingham, MI

consultant 1  
Nowak & Frauss Engineers  
46777 Woodward Ave.  
Pontiac, MI 48342  
p 248.332.7931

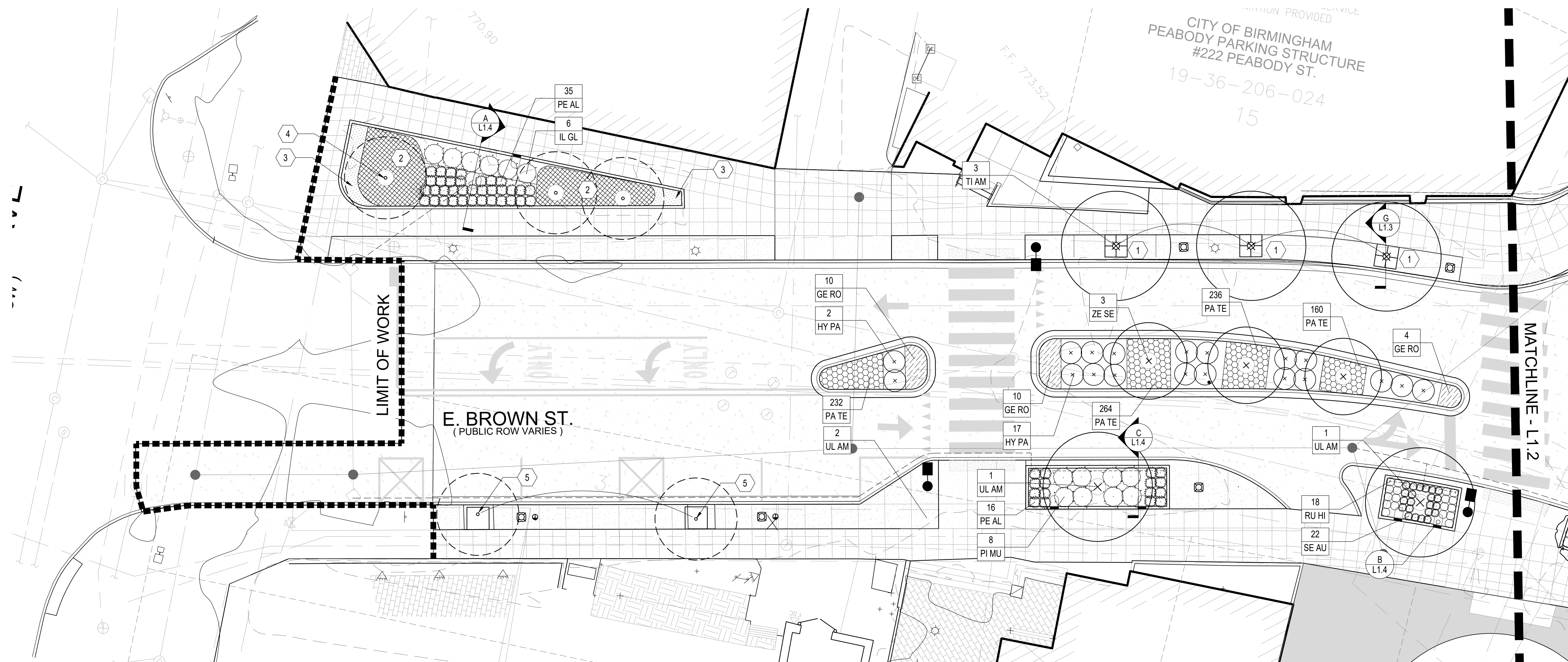

**CONSTRUCTION DOCUMENTS**

Issued for Construction

revision date issued

04.10.2023 BIDS  
03.16.2023 90% CITY REVIEW

seal

issue date 03.16.2023 project number d23106

sheet name  
**LANDSCAPE PLAN**

sheet number

**L1.1**





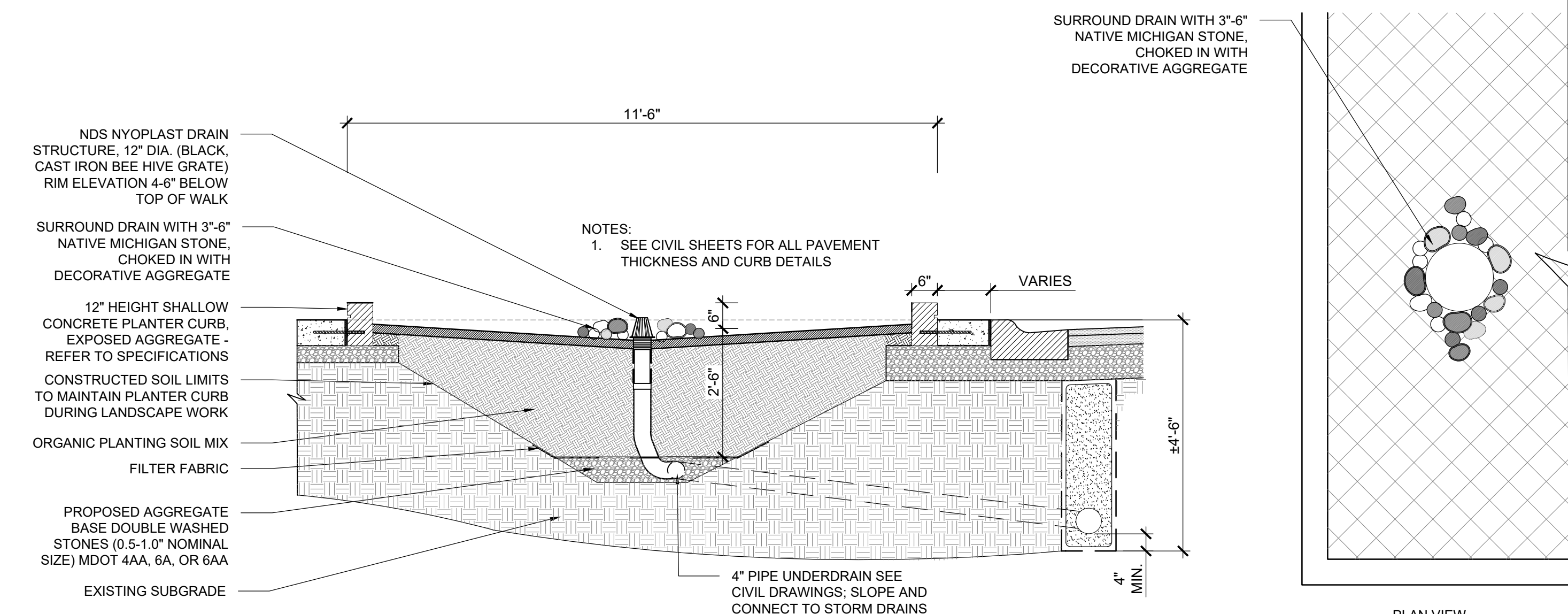

**A PLANTER DRAIN & AGGREGATE SECTION AND PLAN ENLARGEMENT**  
SCALE: 1/2" = 1'-0"

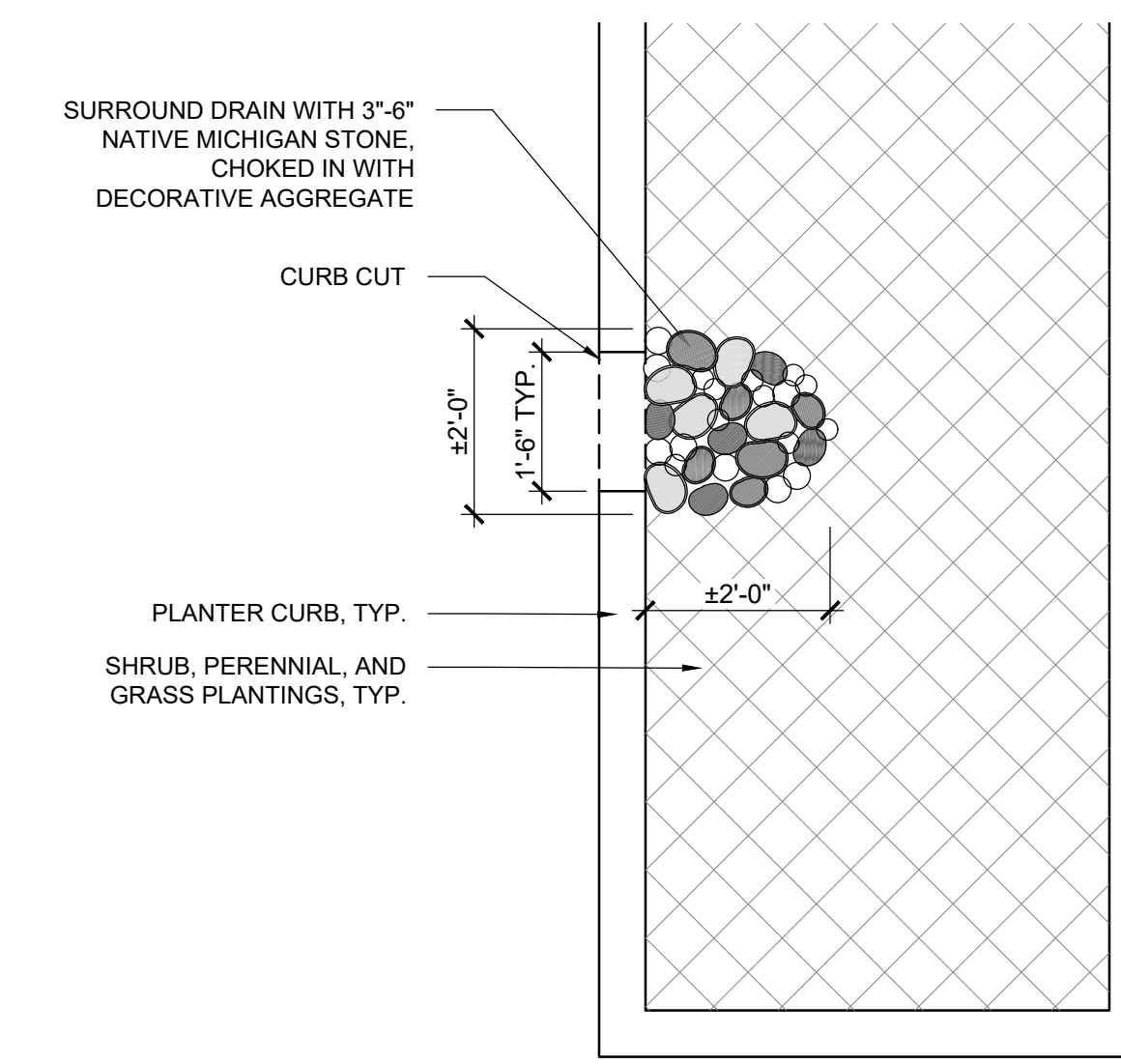

**B TYPICAL AGGREGATE - CURB CUT PLAN ENLARGEMENT**  
SCALE: 1/2" = 1'-0"

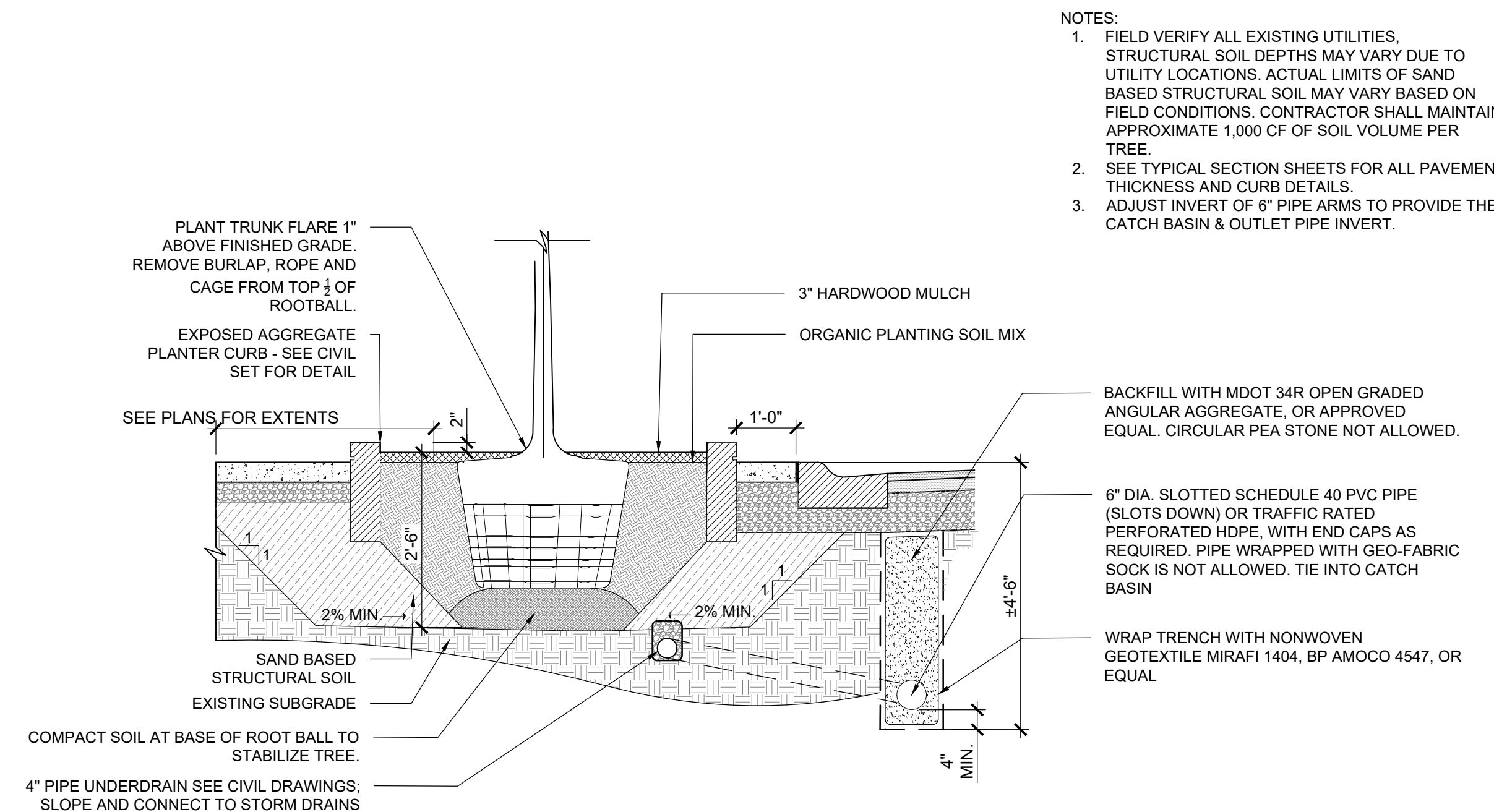

**C TREE PLANTING IN STRUCTURAL SOIL AND PLANTER DRAINAGE DETAIL**  
SCALE: 1/2" = 1'-0"

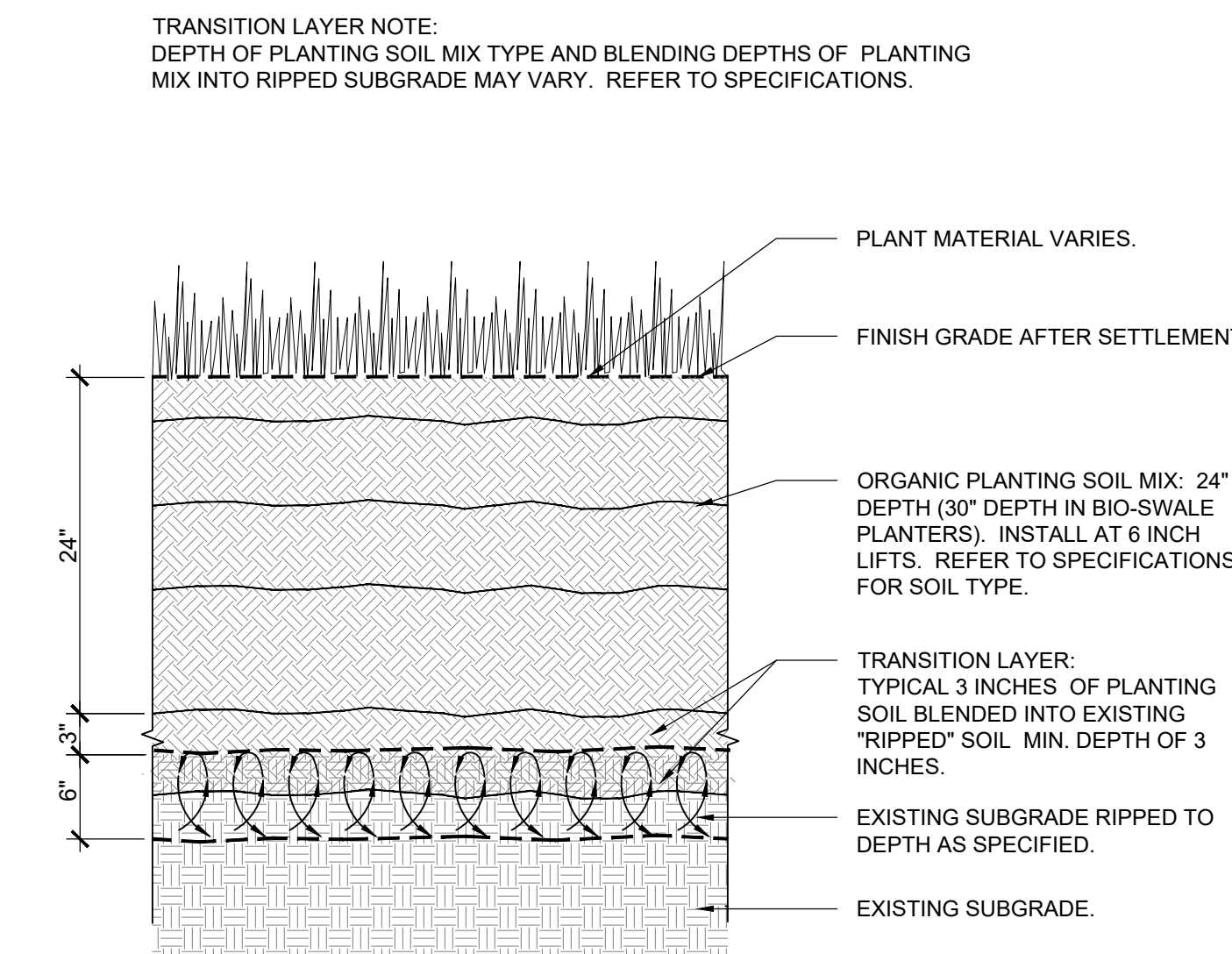

**D ORGANIC PLANTING SOIL MIX INSTALLATION**  
SCALE: 1" = 1'-0"

**CONSTRUCTION DOCUMENTS**  
Issued for Construction

revision	date	issued
04.10.2023		BIDS
03.16.2023		90% CITY REVIEW

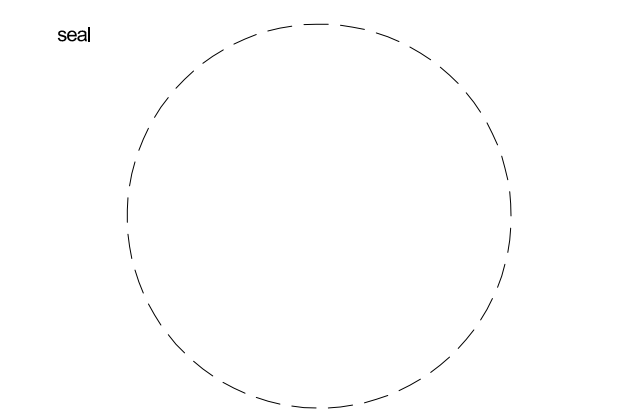

issue date	project number
03.16.2023	d23106

sheet name  
**LANDSCAPE  
DETAILS**  
sheet number

T:\Projects\2023\23106-Birmingham MI\_Brown Street Streetscape\BIM\_CAD\_GIS\CAD\Sheets\d23106-L1-3-LANDSCAPE DETAILS.dwg Apr 10, 2023 - 11:26am-jgpf



PROTO PLANTER FENCE

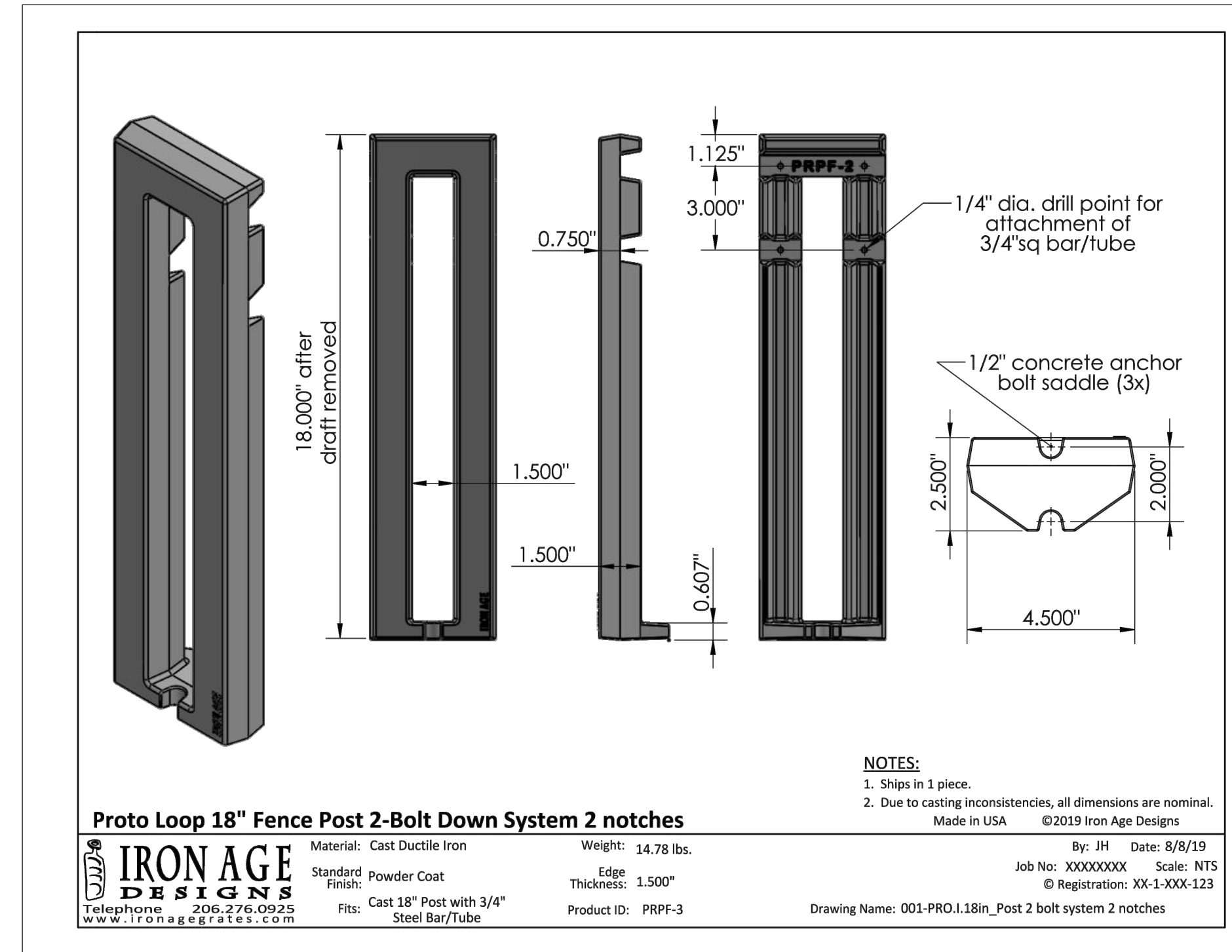

PROTO PLANTER FENCE - CUT SHEET

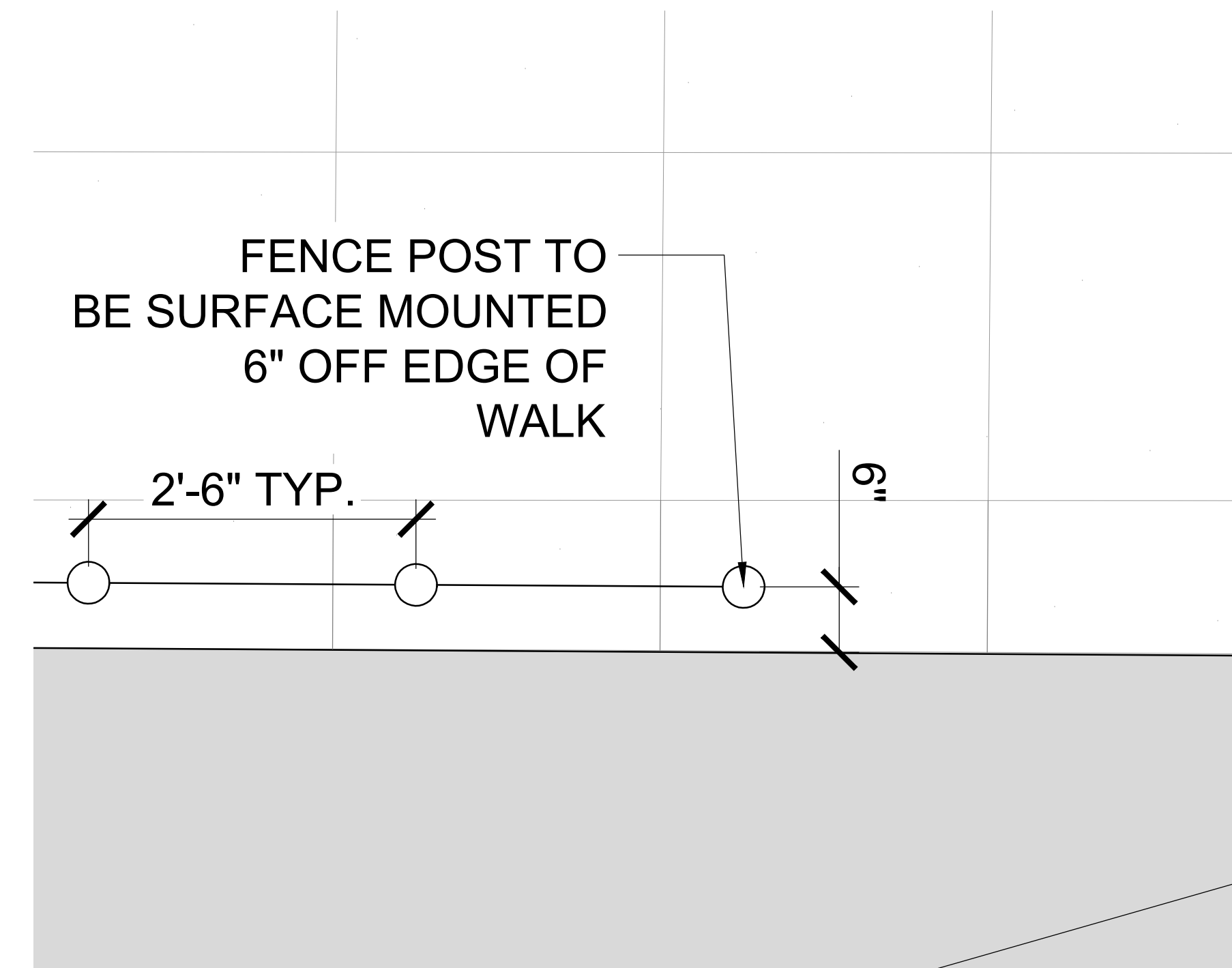

DECORATIVE FENCE ALTERNATE - PLAN ENLARGEMENT

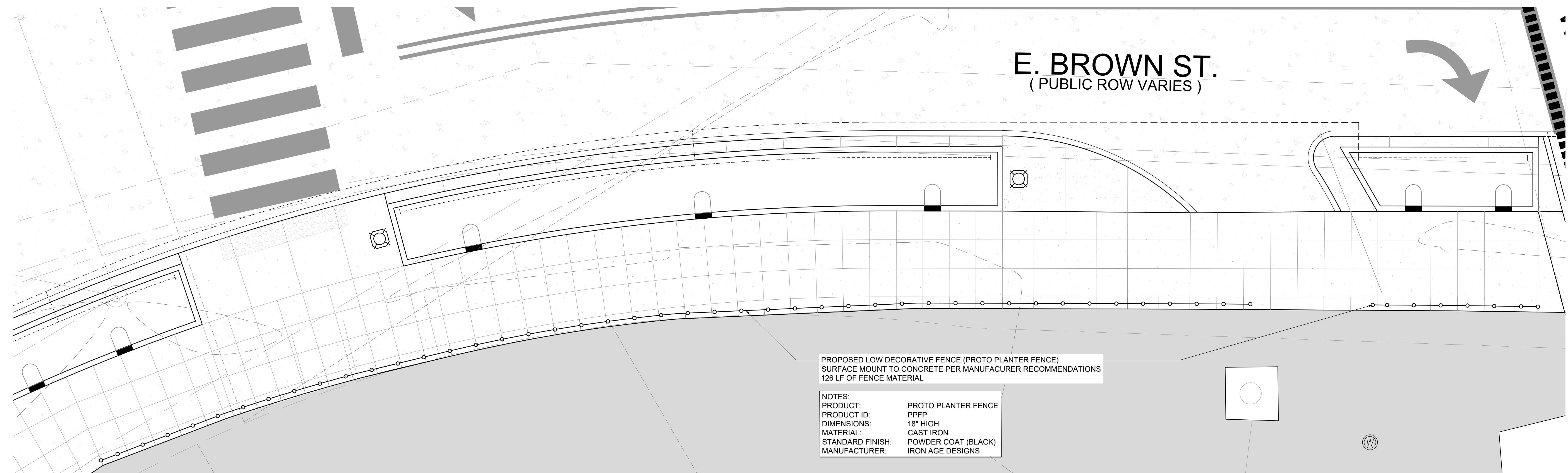

DECORATIVE FENCE ALTERNATE

### CONSTRUCTION DOCUMENTS

Issued for Construction

revision	date	issued
04.10.2023		BIDS
03.16.2023		90% CITY REVIEW

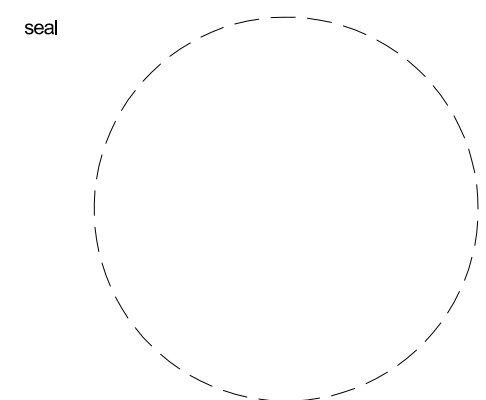

issue date  
03.16.2023

project number  
d23106

sheet name  
**DECORATIVE FENCE  
ALTERNATE**

sheet number

# L1.5



### CODED NOTES:

- 1 NO NEW SOIL TO BE PLACED OVER ROOTBALL OF EXISTING TREES
- 2 BACKFILL EXCAVATED HOLES DUG FOR NEW PLANT MATERIAL WITH ORGANIC PLANT MIX AS NEEDED

### SOILS LEGEND

S1	SOIL TYPE 1 - EXISTING PLANTING BEDS ORGANIC PLANTING SOIL MIX - (DEPTH VARIES, NOT ON ROOTBALL / TREE TRUNK)
S2	SOIL TYPE 2 - PERENNIALS, SHRUBS & TREES ORGANIC PLANTING SOIL MIX - 24" SEE DETAIL D, SHEET L1.4
S3	SOIL TYPE 3: SAND BASED STRUCTURAL SOIL MIX - 30" SEE DETAIL C, SHEET L1.4

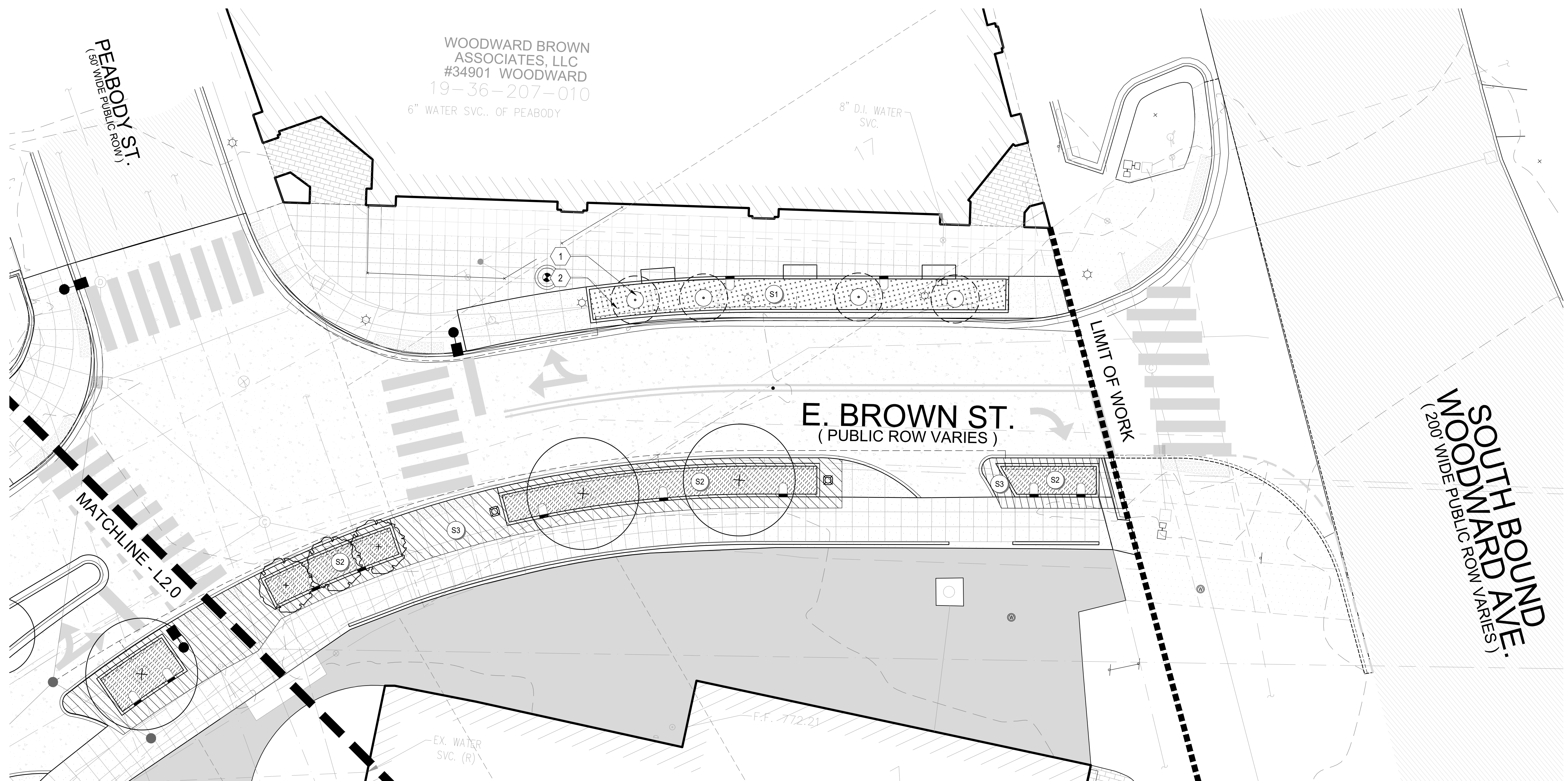

### CONSTRUCTION DOCUMENTS

Issued for Construction

revision	date	issued
04.10.2023		BIDS
03.16.2023		90% CITY REVIEW

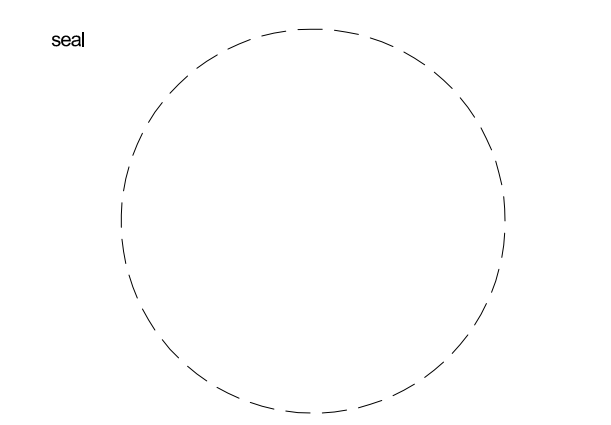

issue date	03.16.2023	project number	d23106
------------	------------	----------------	--------

sheet name  
**SOILS PLAN**

sheet number  
**L2.1**

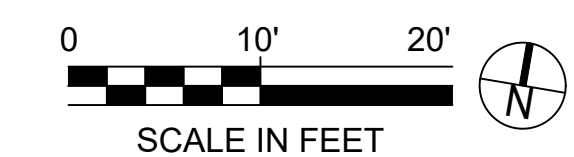

T:\Projects\2023\4219\42196-Birmingham MI - Brown Street Streetscape\BIM\_CAD\_GIS\CAD\Sheets\23106-L2.1-SOILS PLAN.dwg Apr 07, 2023 - 8:46am-jgoff

**ENGINEER'S OPINION OF PROBABLE COST  
BROWN STREET PAVING PROJECT (CONTRACT #5-23P)**

NO.	ITEM DESCRIPTION	PAY UNIT	SHEET C1 Utility	SHEET C2 Utility	SHEET C7 Paving	SHEET C8 Striping/Signage	SITE-ONE Irrigation	MYSK Landscape	TOTAL QUANTITY
<b>SEWER PAY ITEMS</b>									
1	15" Storm Sewer, C76, CLIV, Trench A	LF	212	-	-	-	-	-	212
2	12" Storm Sewer, C76, CLIV, Trench A	LF	23	31	-	-	-	-	54
3	10" Storm Sewer, PVC SDR 26, Trench A	LF	67	-	-	-	-	-	67
4	New 6" Diameter Combined Sewer Manhole (Construct Online)	EA	1	-	-	-	-	-	1
5	New 4'-0" Diameter Storm Manhole w/ 2' Sump & 15" Dia. Gas Trap (Construct Online)	EA	1	-	-	-	-	-	1
6	New 4'-0" Diameter Storm Manhole	EA	4	-	-	-	-	-	4
7	New 12" Diameter PVC Landscape Drain w/ Metal Bee-Hive Grate	EA	1	1	-	-	-	-	2
8	6" Perforated Pipe Underdrain (w/ Trench Detail)	LF	145	220	-	-	-	-	365
9	4" Perforated Pipe Underdrain (w/ Geotextile Sock)	LF	75	145	-	-	-	-	220
10	Sewer Tap, 12"	EA	-	1	-	-	-	-	1
11	Sewer Tap, 6"	EA	-	1	-	-	-	-	2
12	Sewer Tap, 4"	EA	-	1	-	-	-	-	1
13	Reconstruct Manhole (if and where needed)	VF	-	-	-	-	-	-	15
14	Remove & Replace Structure Cover (as directed by City)	LB	-	-	-	-	-	-	825
15	Investigate, Adjust & Shift Casting Location	EA	-	2	-	-	-	-	2
16	Removal and Disposal of Contaminated Material, Type 2	CY	-	-	-	-	-	-	25
17	Removal and Disposal of Contaminated Material, Type 3	CY	-	-	-	-	-	-	25
18	Remove Ex. 12" Storm Sewer	LF	-	36	-	-	-	-	36
19	Abandon Ex. 12" Storm Sewer	LF	36	-	-	-	-	-	36
20	Bulkhead Structure, 12"	EA	1	2	-	-	-	-	3
21	Bulkhead Pipe, 12"	EA	-	-	-	-	-	-	1
22	Bulkhead Pipe, 10"	EA	-	-	-	-	-	-	1
23	Bulkhead Pipe, 6"	EA	-	-	-	-	-	-	1
24	CCTV Sewer Inspection	LS	-	-	-	-	-	-	1
<b>SUBTOTAL SEWER PAY ITEMS</b>									
<b>WATER MAIN PAY ITEMS</b>									
25	New Water Service, 1.5", Trench A, Copper	LF	25	-	-	-	-	-	25
26	Water Service Connection, 1.5"	EA	1	-	-	-	-	-	1
<b>SUBTOTAL WATER MAIN PAY ITEMS</b>									
<b>PAVING PAY ITEMS</b>									
27	Station Grading	STA	-	-	4.4	-	-	-	4.4
28	Subgrade Undercutting	CY	-	-	-	-	-	-	100
29	Excavation for Tree Wells	CY	-	-	-	-	-	-	125
30	Removing Concrete Sidewalk & Ramp (sawcutting included)	SY	515	320	-	-	-	-	835
31	Removing Pavement Full Depth (Curb & Gutter included)	SY	1,060	910	-	-	-	-	1,970
32	Aggregate Base, MDOT 21AA Limestone, 8"	SY	950	760	-	-	-	-	1,710
33	Concrete Pavement, Non-reinforced, 9", incl. integral Detail F2 Curb & Gutter	SY	860	725	-	-	-	-	1,585
34	Furnish & Install Tree Grate	EA	-	-	3	-	-	-	3
35	Concrete Sidewalk, 6", Scoring Treatment	SF	-	-	8445	-	-	-	8,445
36	Concrete Sidewalk, 6", Scoring Treatment (Includes Ramps)	SF	-	-	855	-	-	-	855
37	Concrete Sidewalk, 6", Scoring Treatment	SF	-	-	400	-	-	-	400
38	Concrete Sidewalk, 4", Exposed Aggregate, Scoring Treatment	SF	-	-	1698	-	-	-	1,698
39	Concrete Sidewalk, 6", Exposed Aggregate, Scoring Treatment	SF	-	-	217	-	-	-	217
40	Handicap Ramp Truncated Domes (per ramp)	SF	48	144	-	-	-	-	192
41	Concrete Curb & Gutter, 18", MDOT Type F2, Modified	LF	220	11	-	-	-	-	231
42	20" Hgt. Planter Curb, Exposed Aggregate	LF	101	411	-	-	-	-	512
43	12" Hgt. Planter Curb, Exposed Aggregate	LF	144	-	-	-	-	-	144
44	Integral Curb at Back of Walk for Pedestrian Protection	LF	-	126	-	-	-	-	126
45	Remove Ex. 4" Skip Lane Markings on Brown Street (west of Old Woodward)	LF	-	-	-	90	-	-	90
46	Pavement Marking, Polyurea, 6 inch, Solid Lane Line, White	LF	-	-	-	190	-	-	190
47	Pavement Marking, Polyurea, 6 inch, Dotted Lane Line, White	LF	-	-	-	100	-	-	100
48	Pavement Marking, Polyurea, 4 inch, White	LF	-	-	-	228	-	-	228
49	Pavement Marking, Polyurea, 4 inch, Yellow	LF	-	-	-	515	-	-	515
50	Pavement Marking, Polyurea, 24 inch Stop Bar, White	LF	-	-	-	55	-	-	55
51	Pavement Marking, Polyurea, 24 inch Crosshatching, White	LF	-	-	-	384	-	-	384
52	Pavement Marking, Polyurea, Rt Turn Arrow, White	EA	-	-	-	3	-	-	3
53	Pavement Marking, Polyurea, Lt Turn Arrow, White	EA	-	-	-	1	-	-	1
54	Pavement Marking, Polyurea, Straight/Left Arrow, White	EA	-	-	-	2	-	-	2
55	Pavement Marking, Polyurea, Only, White	LF	-	-	-	2	-	-	2
56	Recessing Pav Mkrng, Longfl	LF	-	-	-	1023	-	-	1,023
57	Recessing Pav Mkrng, Transv	SF	-	-	-	1450	-	-	1,450
58	Adjust Structure Cover	EA	3	5	-	-	-	-	8
59	Cold Patch	TON	-	-	-	-	-	-	25
60	Maintenance Aggregate	LS	-	-	-	-	-	-	1
<b>SUBTOTAL PAVING PAY ITEMS</b>									
<b>IRRIGATION PAY ITEMS</b>									
61	Motor Pk	EA	-	-	-	-	1	-	1
62	Sprinkler Assembly	EA	-	-	-	-	76	-	76
63	Valve Assembly	EA	-	-	-	-	4	-	4
64	1-1/2 inch PVC Mainline	LF	-	-	-	-	202	-	202
65	1-1/2 inch Polyethylene lateral line	LF	-	-	-	-	5	-	5
66	1 inch Polyethylene lateral line	LF	-	-	-	-	936	-	936
67	Communication Cable - two wire	LF	-	-	-	-	202	-	202
68	Irrigation Controller	EA	-	-	-	-	1	-	1
69	Rain Sensor	EA	-	-	-	-	1	-	1
70	Two Wire Decoders	EA	-	-	-	-	4	-	4
71	4" PVC Sleeve	LF	-	-	-	-	145	-	145
72	2" PVC Sleeve	LF	-	-	-	-	278	-	278
<b>SUBTOTAL IRRIGATION PAY ITEMS</b>									
<b>LANDSCAPE PAY ITEMS</b>									
73	Structural Soil Mix (30" depth)	CFT	-	-	-	-	-	5,073	5,073
74	Organic Plant Soil Mix - Plant Beds (24" depth)	CFT	-	-	-	-	-	3,713	3,713
75	Native MI Stone (3"-6") choked in w/ decorative aggregate	LS	-	-	-	-	-	1	1
76	Shredded Hardwood Mulch (3" depth)	CY	-	-	-	-	-	24	24
77	TILIA AMERICANA 'MCKSENTRY' (3-3.5" CAL.)	EA	-	-	-	-	-	3	3
78	ULMUS AMERICANA 'PRINCETON' (3-3.5" CAL.)	EA	-	-	-	-	-	4	4
79	ZELKOVA SERRATA 'JES-KW1' (3-3.5" CAL.)	EA	-	-	-	-	-	3	3
80	MALUS X 'JEFSPIRE' (2" CAL.)	EA	-	-	-	-	-	3	3
81	HYDRANGEA PANICULATA 'JANE' (#5)	EA	-	-	-	-	-	31	31
82	ILEX GLABRA 'SHAMROCK' (#3)	EA	-	-	-	-	-	6	6
83	JUNIPERUS SQUAMATA 'BLUE STAR' (#3)	EA	-	-	-	-	-	18	18
84	PIRUS MUGO 'HONEY COMB' (#3)	EA	-	-	-	-	-	21	21
85	GERANIUM X ROZANNE' (#1)	EA	-	-	-	-	-	24	24
86	PACHYGANRA TERMINALIS 'GREEN CARPET' (24" FLAT)	EA	-	-	-	-	-	882	882
87	PEROVSKIA LITTLE SPRE' (#2)	EA	-	-	-	-	-	41	41
88	RUDEBECKIA HIRTA (#1)	EA	-	-	-	-	-	35	35
89	PENNETUM ALOPECUROIDES 'LITTLE BUNNY' (#2)	EA	-	-	-	-	-	91	91
90	SELISERIA AUTUMNALIS (#1)	EA	-	-	-	-	-	48	48
<b>SUBTOTAL LANDSCAPE PAY ITEMS</b>									
<b>GENERAL PAY ITEMS</b>									
91	Critical Path Time Schedule	LS	-	-	-	-	-	-	1
92	Mobilization, (Max. 5% of Bid)	LS	-	-	-	-	-	-	1
93	Water and Sewer Allowance	LS	-	-	-	-	-	-	1
94	Street Light Conduit, 4" PVC Schedule 40, 4' deep	LF	-	-	-	-	-	-	90
95	Salvage Existing Signs	LS	-	-	-	-	-	-	1
96	New Signs	SF	-	-	-	-	-	-	64
97	Sign Post, U-Channel	LF	-	-	-	-	-	-	108
98	Modify Steps & Railing at Peabody Parking Structure	LS	-	-	-	-	-	-	1
99	Removing Street Light Foundation	EA	-	-	-	-	-	-	8
100	Parking Meter Post	EA	-	-	-	-	-	-	2
101	Inlet Filter	EA	-	-	-	-	-	-	10
102	Road Closure Assessment, _____ Days @ \$5,000/Day	DAYS	-	-	-	-	-	-	-
103	Traffic Maintenance and Control, _____ Days @ \$500/Day (Minimum)	DAYS	-	-	-	-	-	-	-
<b>SUBTOTAL GENERAL PAY ITEMS</b>									
<b>ALTERNATE #1</b>									
104	DEDUCT - Integral Curb at Back of Walk for Pedestrian Protection	LF	-	-	-	126	0	-	-126
105	Low Ornamental Fence	LF	-	-	-	126	126	-	126

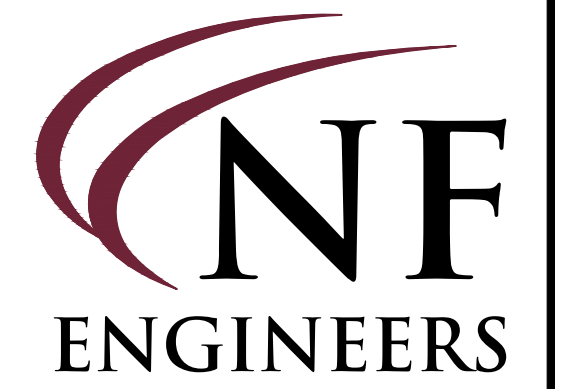

CIVIL ENGINEERS  
LAND SURVEYORS  
LAND PLANNERS

NOWAK & FRAUS ENGINEERS  
46777 WOODWARD AVE.  
PONTIAC, MI 48342-5032  
TEL (248) 332-7931  
FAX (248) 332-8257  
WWW.NFE-ENGR.COM

SEAL

PROJECT  
Brown Street Paving Project  
Contract #5-23(P)



Engineering Department  
151 Martin Street  
Birmingham, MI 48012

PROJECT LOCATION  
Part of the Northeast 1/4  
of Section 36  
Town 2 North,  
Range 10 East  
City of Birmingham,  
Oakland County, Michigan

SHEET  
Quantities



Know what's below  
Call before you dig.

DATE ISSUED/REVISED  
03-16-2023 - 905 CITY REVIEW  
04-10-2023 - BIDS  
04-26-2023 - ADDENDUM 1

DRAWN BY:  
G. Viju

DESIGNED BY:  
G. Viju

APPROVED BY:  
B. Buchholz

DATE:  
03-16-2023

SCALE: N.T.S.

NFE JOB NO. SHEET NO.  
D162-01 Q1



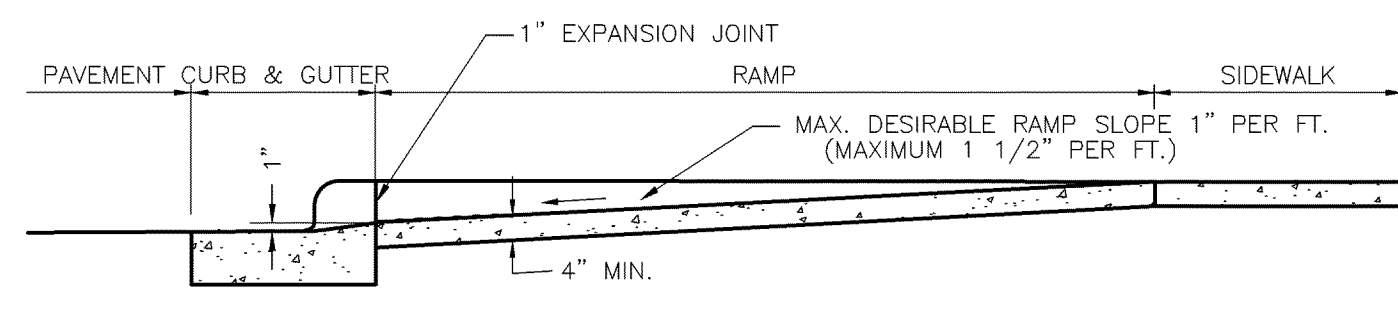

SECTION A-A  
N.T.S.

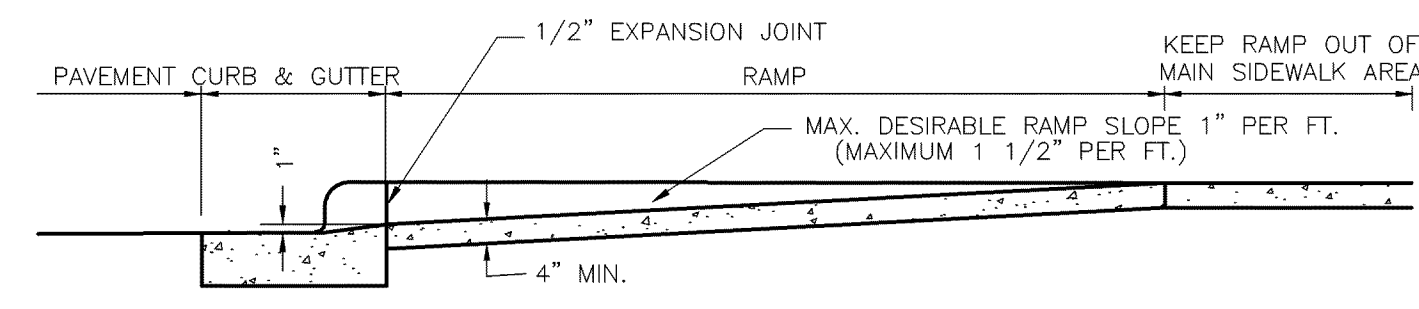

SECTION G-G  
N.T.S.

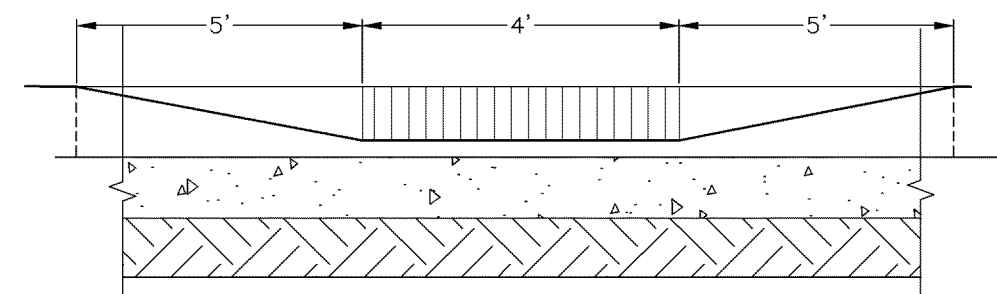

SECTION B-B  
N.T.S.

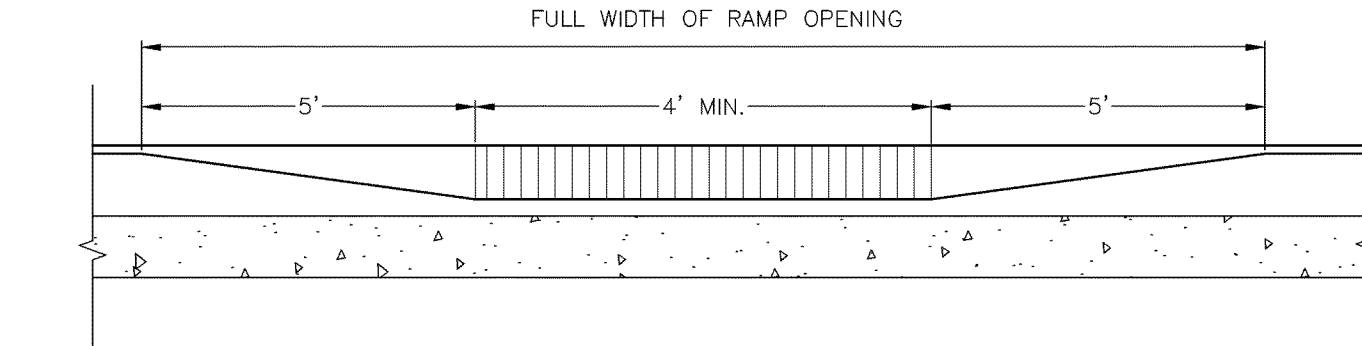

SECTION H-H  
N.T.S.

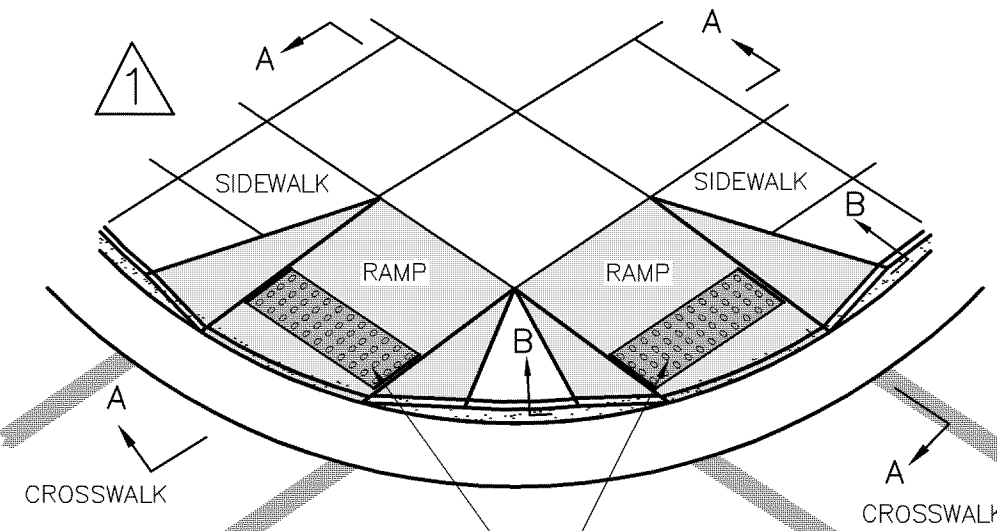

SIDEWALK RAMP TYPE 1  
(TWO RAMP ARE SHOWN)  
N.T.S.

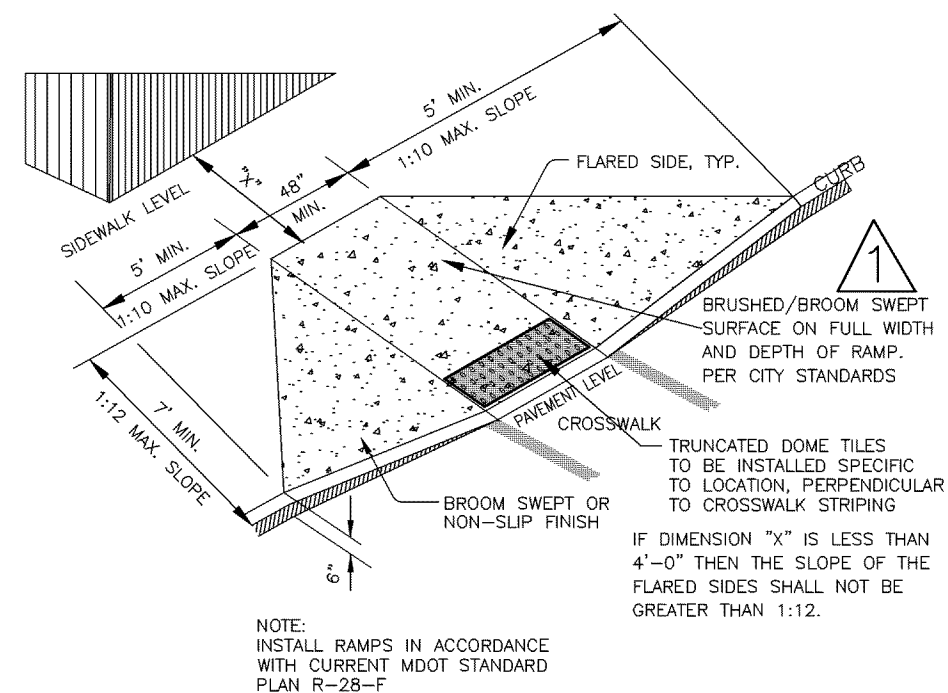

CURB RAMP FOR DISABLED  
N.T.S.

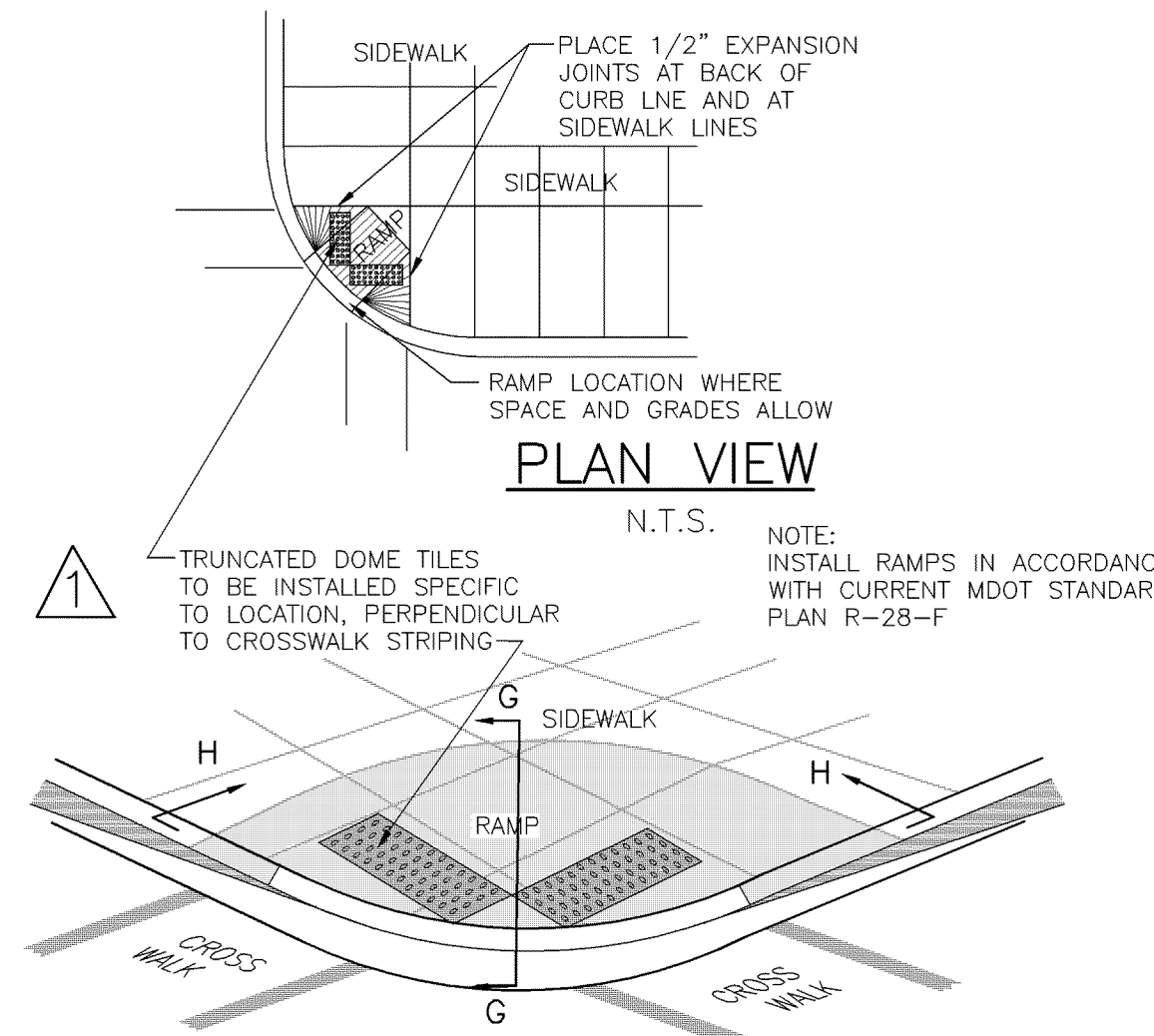

SIDEWALK RAMP TYPE 3  
N.T.S.

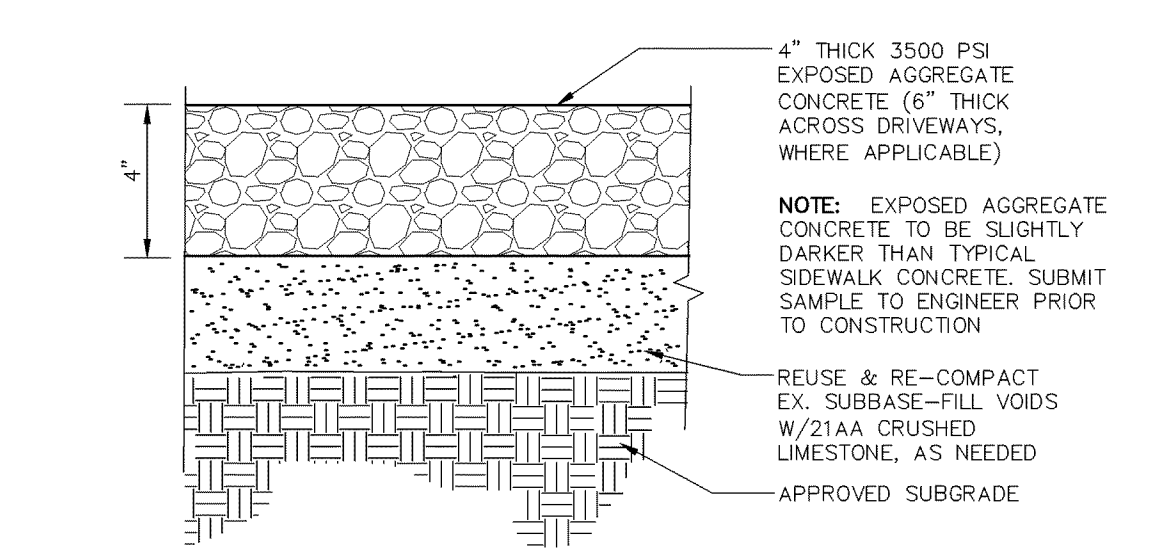

- EXPOSED AGGREGATE SIDEWALK PROCEDURE:**
1. SURFACE RETARDANT: EXPOSED AGGREGATE FINISH SHALL BE EXPOSED BY USE OF SURFACE RETARDANT "PRECO EAC-5" OR APPROVED EQUAL.
  2. CONCRETE SHALL BE PLACED, LEVELED & FLOATED IN A NORMAL FASHION (SEEDING WILL NOT BE PERMITTED).
  3. IMMEDIATELY AFTER THE SLAB HAS BEEN SCREENED AND DABLED, THE AGGREGATE SHALL BE WASHED IN A UNIFORM MANNER UNTIL ENTIRE SURFACE IS EXPOSED. A THOROUGH "EXPOSING" OF THE EMBEDDED AGGREGATE SHALL BE PERFORMED UNTIL ALL AGGREGATE IS LEFT JUST ABOVE THE SURFACE, LEAVING NO HOLES OR OPENING IN THE SURFACE.
  4. THE SURFACE SHALL THEN BE BRUSHED AND WASHED UNTIL ALL THE AGGREGATE IS EXPOSED AND FREE OF CEMENT FILM.
  5. AFTER INITIAL CURING, THE EXPOSED AGGREGATE SIDEWALK SHALL BE SEALED WITH TRANSPARENT CONCRETE SEALER, AS APPROVED BY THE ENGINEER.

EXPOSED AGGREGATE WALK DETAIL  
N.T.S.

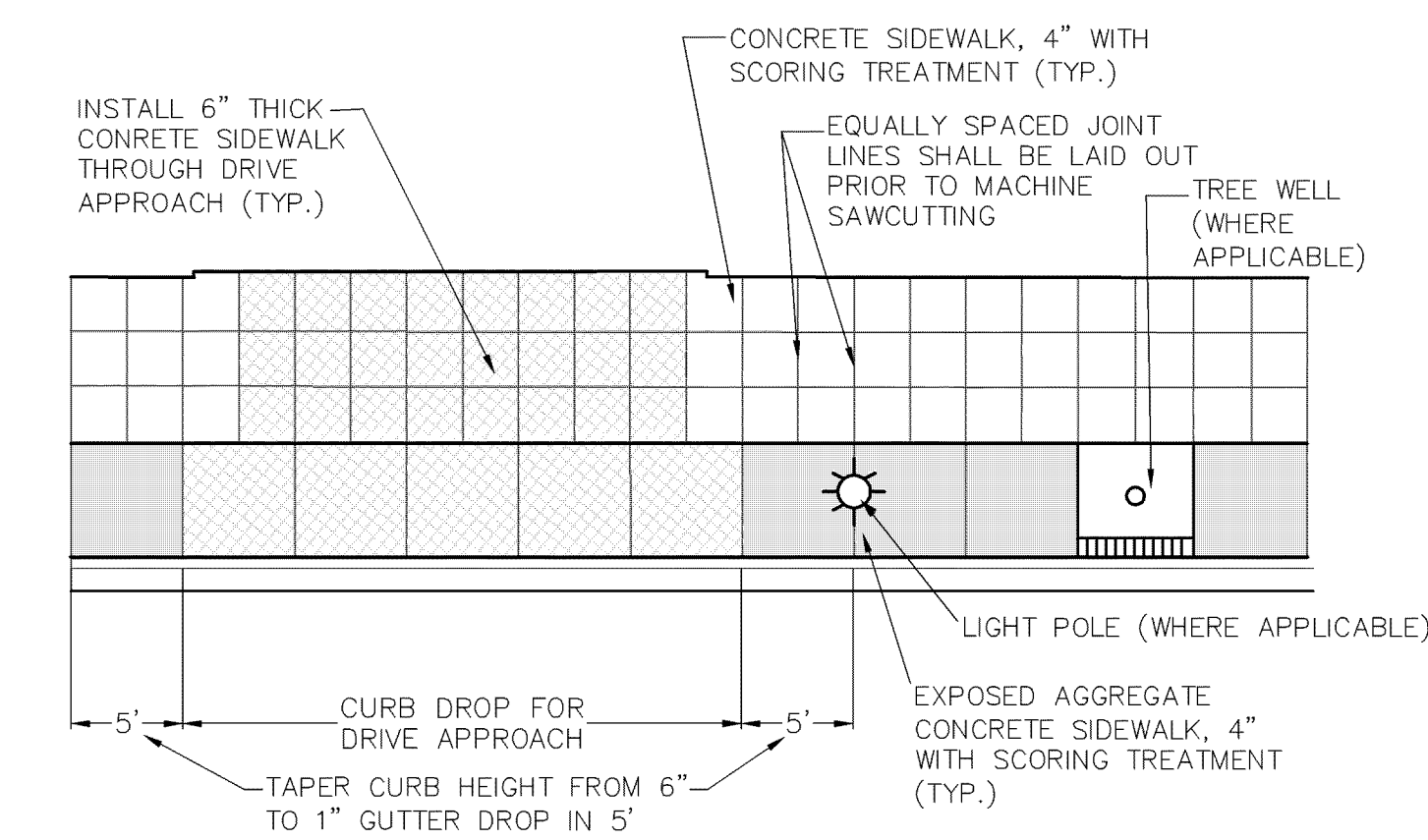

CONCRETE DRIVE APPROACH & SIDEWALK JOINT LAYOUT  
N.T.S.

**CONCRETE SIDEWALK MIX DESIGNS:**

- PLAIN CONCRETE MIX:**
- SAND: 2NS SAND, ASTM C-33 1350 POUNDS
  - COURSE AGGREGATE: 6AA LIMESTONE PRESQUE ISLE ASTM C-33 1680 POUNDS
  - CEMENT: TYPE 1, ASTM C150 588 POUNDS
  - WATER: CITY TAP WATER 31.5 GALLONS
  - ADMIXTURE: ASTM C260, DAREX A.E.A. BY W.R. GRACE CO. 11.3 OZ./CU. YD.
- EXPOSED AGGREGATE CONCRETE MIX:**
- SAND: 2NS SAND, ASTM C-33 1080 POUNDS
  - COURSE AGGREGATE: 17A ASTM C-33 1980 POUNDS
  - CEMENT: TYPE 1, ASTM C150 588 POUNDS
  - WATER: CITY TAP WATER 31.5 GALLONS
  - ADMIXTURE: ASTM C260, DAREX A.E.A. BY W.R. GRACE CO. 11.3 OZ./CU. YD.
- \* PEBBLE, WASHED, SUBMIT SAMPLE
- CONCRETE STRENGTH SHALL BE 3,500 PSI AT 28 DAYS, WITH 6% + OR - ENTRAINED AIR. MIX DESIGN SHALL NOT HAVE LESS THAN 6.25 SACKS OF CEMENT PER CUBIC YARD AND SHALL BE APPROVED BY THE CITY OF BIRMINGHAM ENGINEERING.

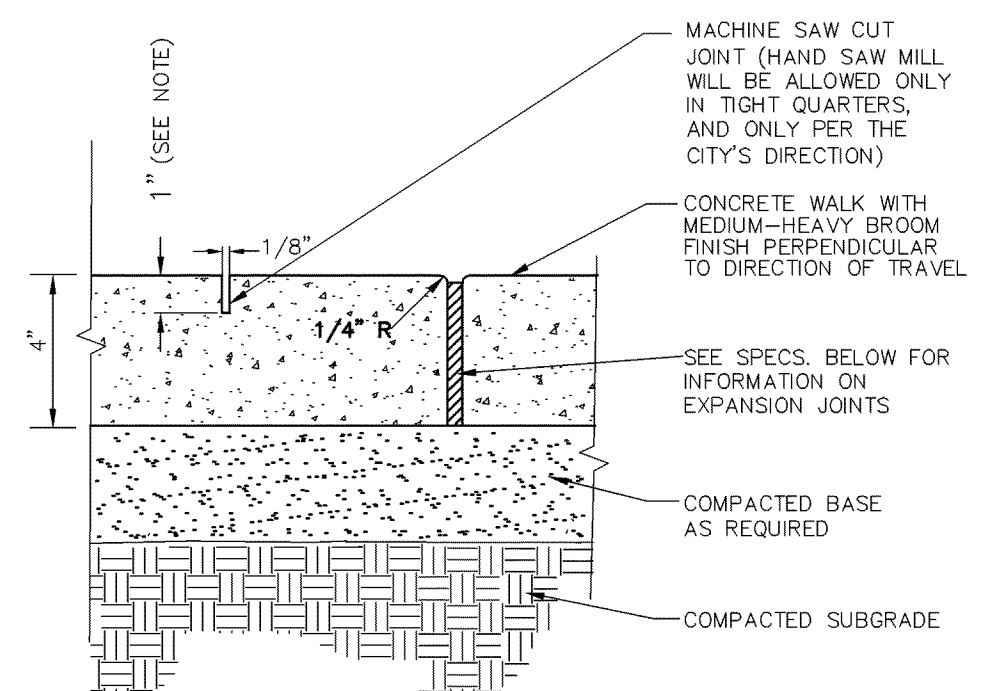

- NOTE:**
1. SAWCUT CONTROL JOINTS - 2" DEPTH, EVERY 100 SF OF PAVING MAX.
  2. SQUARE PATTERN SAWCUT JOINTS, 1" DEPTH, APPROX. EVERY 2'-5" X 2'-5" GRID, AS SHOWN.
  3. PROVIDE EXPANSION JOINTS EVERY 400 SF OF PAVING MAX.
- EXPANSION JOINT MATERIAL SPECS:**
1. EXPANSION JOINT MATERIAL: RESILIENT, NON-EXTRUDING TYPE PREMOLDED BITUMINOUS IMPREGNATED FIBERBOARD.
  2. SEALANT BACKER ROD: COMPRESSIBLE ROD STOCK OF POLYETHYLENE FOAM OR OTHER FLEXIBLE, PERMANENT, DURABLE NON-ABSORPTIVE MATERIAL AS RECOMMENDED FOR COMPATIBILITY BY SEALANT MANUFACTURE. TEMPORARILY INSTALL ABOVE FIBER BOARD TO CREATE SPACE FOR JOINT SEALANT AT THE APPROPRIATE GRADE. REMOVE PRIOR TO INSTALLING JOINT SEALANT.
  3. JOINT SEALANT: TWO PART POLYSULFIDE SEALANT, SELF LEVELING, LIGHT GRAY COLOR. SUBMIT COLOR SAMPLE FOR APPROVAL. FEDERAL SPECIFICATIONS TT-5-8027E, TYPE 1, DOW CORNING #750 OR EQUAL. INSTALL AFTER REMOVING BACKER ROD TO COMPLETELY COVER FIBER BOARD.

SAWCUT AND EXPANSION JOINT DETAIL FOR CONCRETE SIDEWALK  
N.T.S.

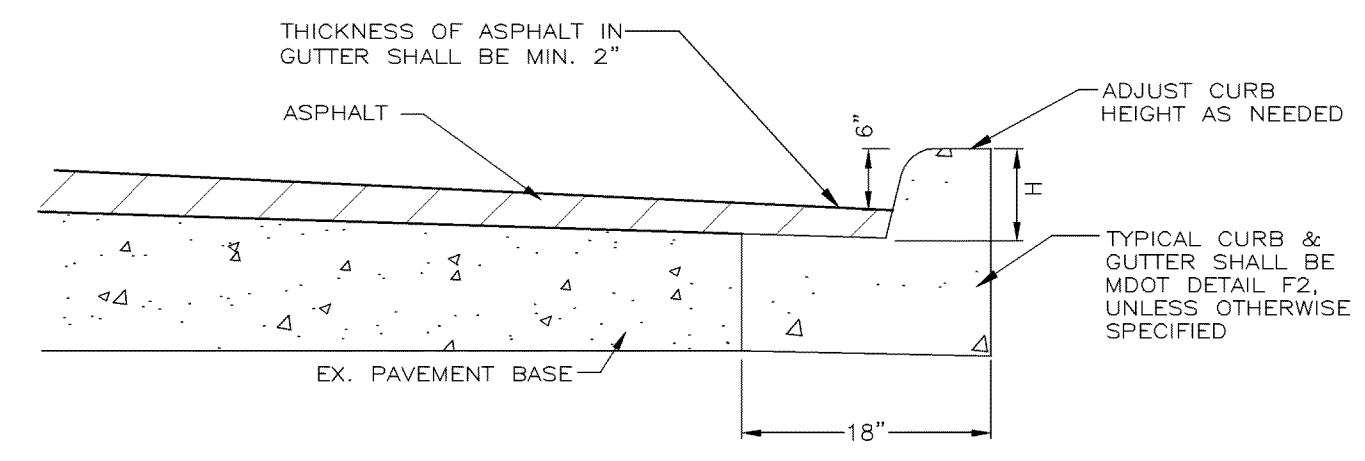
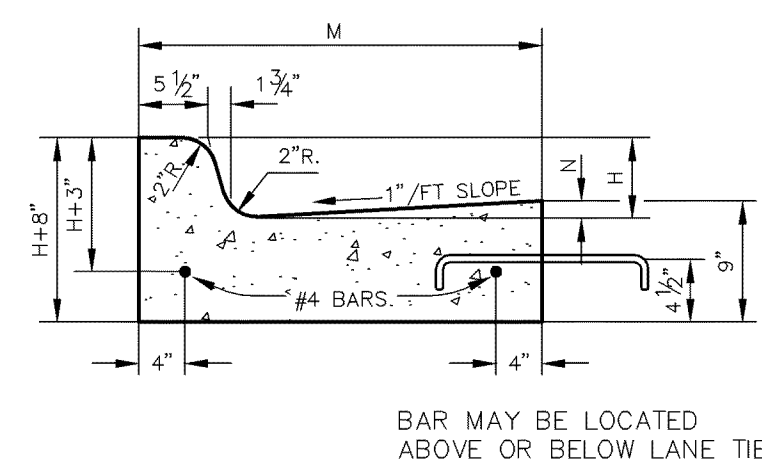

MDOT DETAIL F  
(WITH ASPHALT OVERLAY)  
N.T.S.

DETAIL	DIMENSIONS		LANE TIES	CONCRETE CU. YD./LIN. FT.
	M	N		
F1	1'-6"	7/8"	AS SHOWN	0.0484
F2	1'-6"	7/8"	OMITTED	0.0484

**HANDICAP TRUNCATED DOMES**

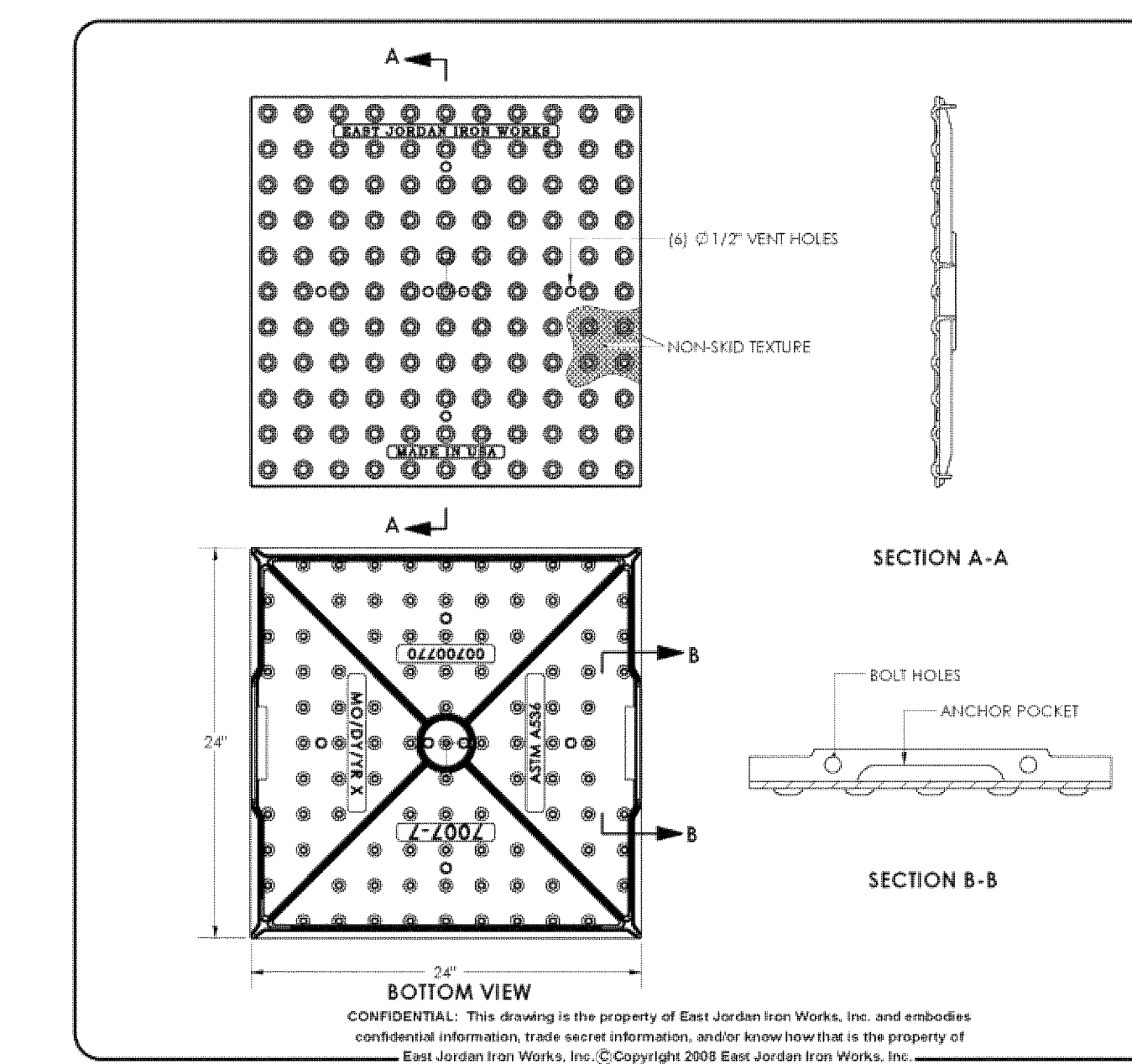

**EJW EAST JORDAN**  
800-626-4663  
WWW.EJW.COM  
MADE IN USA

PRODUCT NUMBER  
**00700770**

CATALOG NUMBER  
**7007-7**

**DETECTABLE WARNING PLATE**

LOAD RATING  
**HEAVY DUTY**

COATING  
**DIPPED**

ESTIMATED WEIGHT  
COVER: 41 LBS

MATERIAL SPECIFICATION  
DUCTILE IRON  
ASTM A536

AREA OF PLATE  
4.0 SF

DESIGNATES  
MACHINED SURFACE

DRAWN  
KPK

DATE  
07/27/08

LAST REVISED  
KPK

DATE  
03/31/2008

REFERENCE INFORMATION  
00700770

- NOTES:**
1. SURFACE TEXTURE OF SIDEWALK RAMPS SHALL BE THAT OBTAINED BY A COURSE BROOMING, TRANSVERSE TO THE SLOPE OF THE RAMP.
  2. CARE SHALL BE TAKEN TO ASSURE A UNIFORM GRADE ON SIDEWALK RAMPS, FREE OF SAGS AND SHORT GRADE CHANGES.
  3. IF POSSIBLE, DRAINAGE STRUCTURES SHOULD NOT BE PLACED IN LINE WITH RAMPS. EXCEPT WHERE EXISTING DRAINAGE STRUCTURES ARE BEING UTILIZED IN THE NEW CONSTRUCTION, LOCATION OF THE RAMP SHOULD TAKE PRECEDENCE OVER LOCATION OF DRAINAGE STRUCTURE.
  4. SIDEWALK RAMP 3 SHALL BE INSTALLED ONLY AT THE CITY'S DIRECTION.
  5. REMOVE AND REPLACE CONCRETE CURB AND GUTTER SECTION AT CURB DROPS ON NON-ASPHALT SURFACED GUTTERS. USE EXISTING JOINTS OR SAW CUT FOR JOINTS. SAW CUT AT 18" FROM BACK OF CURB (FOR CURVED SECTIONS SAW CUT AT MINIMUM OF 12" AND AT A MAXIMUM OF 24" FROM BACK OF CURB). TIE NEW CONCRETE SECTION TO EXISTING PAVEMENT WITH HOOK BOLTS OR RED HEADS AT MAXIMUM OF 40" C.C.

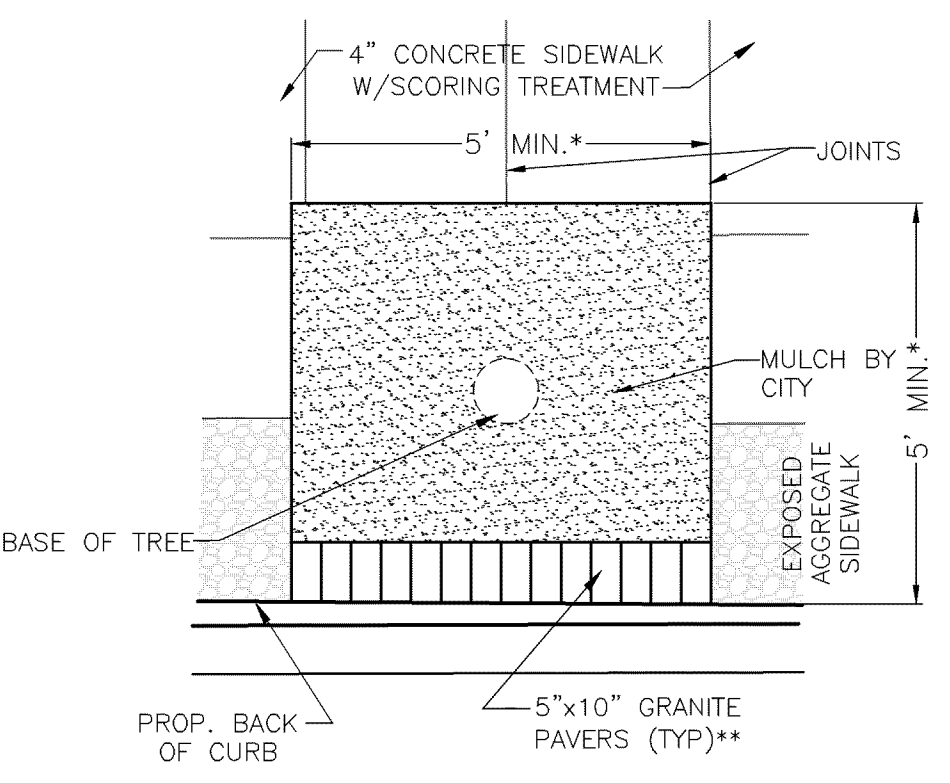

TREE WELL DETAIL #1  
N.T.S.

- NOTE:**  
INSTALL 2 - 2" PVC SLEEVES BETWEEN TREE WELLS FOR FUTURE UNDERGROUND IRRIGATION, AS REQUIRED. INSTALLATION PER THE CITY OF BIRMINGHAM STANDARDS. TIE INTO PROPOSED WATER METER PITS.
- \*TREE WELL NOTE:**  
TREE WELL DIMENSIONS CAN BE MODIFIED BASED ON RIGHT-OF-WAY CONSTRAINTS.
- \*\*GRANITE PAVER NOTE:**  
GRANITE PAVER INSTALLATION SHALL APPLY FOR TREE WELLS ADJACENT TO PARALLEL PARKING SPACES ON A STREET. GRANITE PAVERS SHALL BE "CARNE LIAN" (COLOR) BY COLD SPRING GRANITE COMPANY SET IN A FULL MORTAR BED WHERE INDICATED ON THE DRAWINGS. SUBMIT SAMPLES OF PAVERS (FOR COLOR AND FINISH) AND GROUT COLOR TO CITY OF BIRMINGHAM ENGINEERING FOR APPROVAL. LAYOUT PATTERN IS AS NOTED IN THE PLANS.

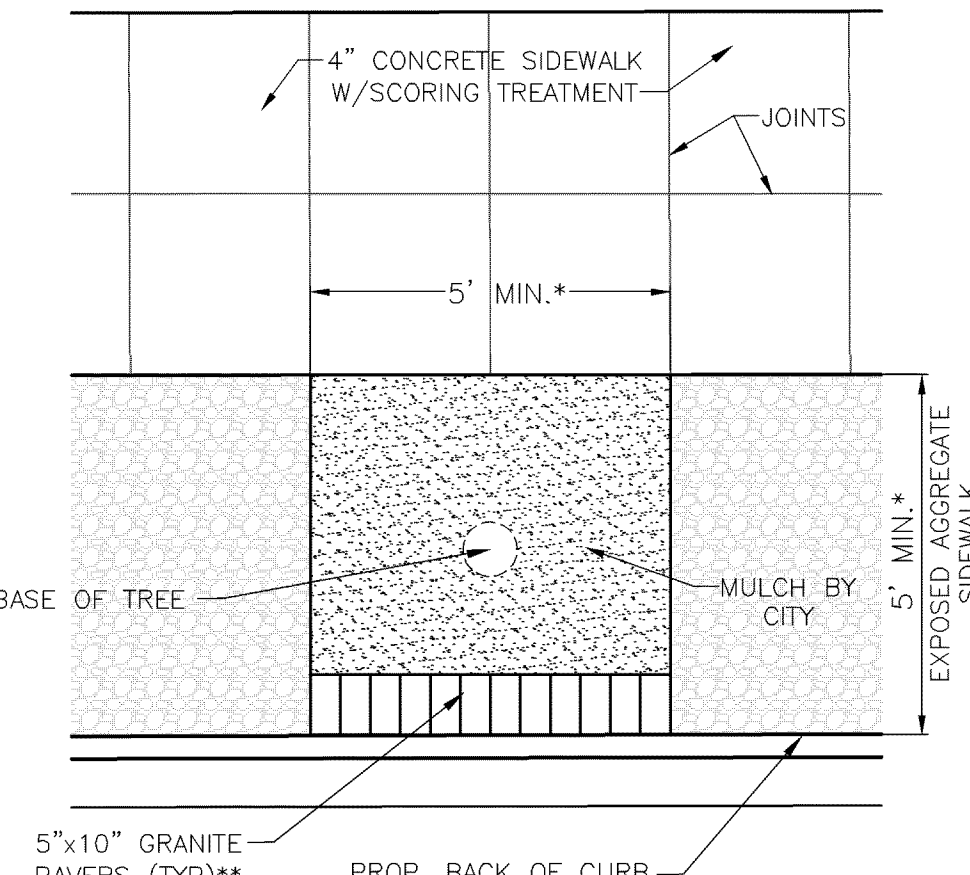

TREE WELL DETAIL #2  
N.T.S.

REVISIONS			CITY OF BIRMINGHAM, MICHIGAN ENGINEERING DEPARTMENT	
No.	DATE	BY		
Added Truncated Dome details	07-05-07	City		
Revised Truncated Dome details	06-26-08	City		

**CBD STREETSCAPE STANDARD DETAILS**

SCALE: HORIZONTAL  
VERTICAL

DRAWN BY: NF  
CHECKED BY: SHEET OF SHEETS

ACCT. NO.  
APPROVED BY: CITY ENGINEER  
DATE: April 4, 2003

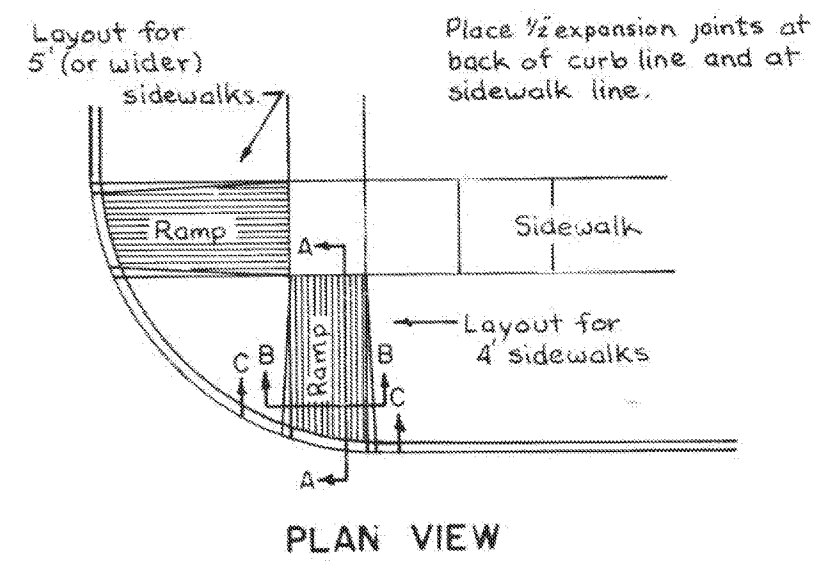

PLAN VIEW

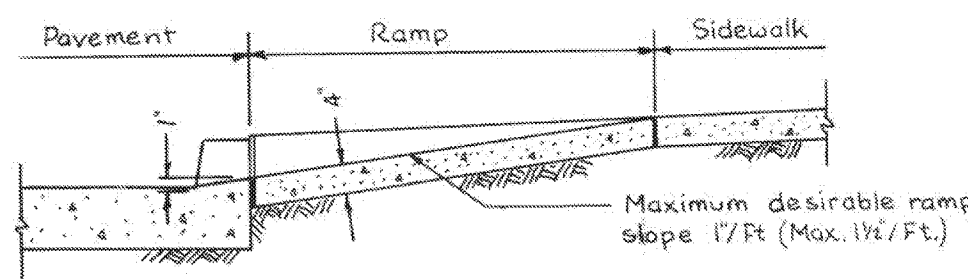

SECTION A-A

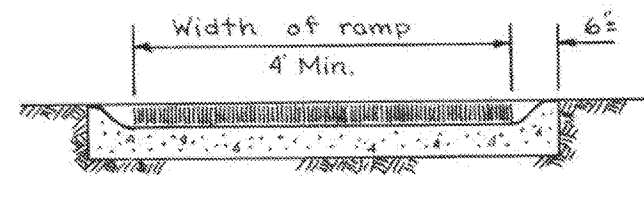

SECTION B-B

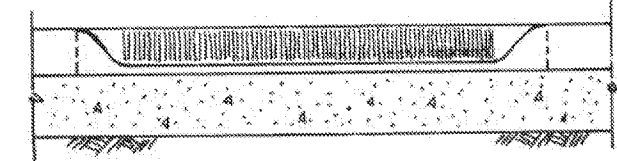

SECTION C-C

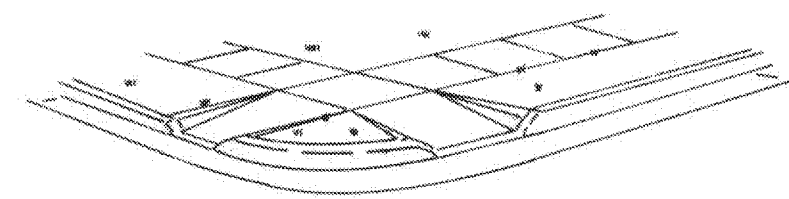

SIDEWALK RAMP TYPE 1

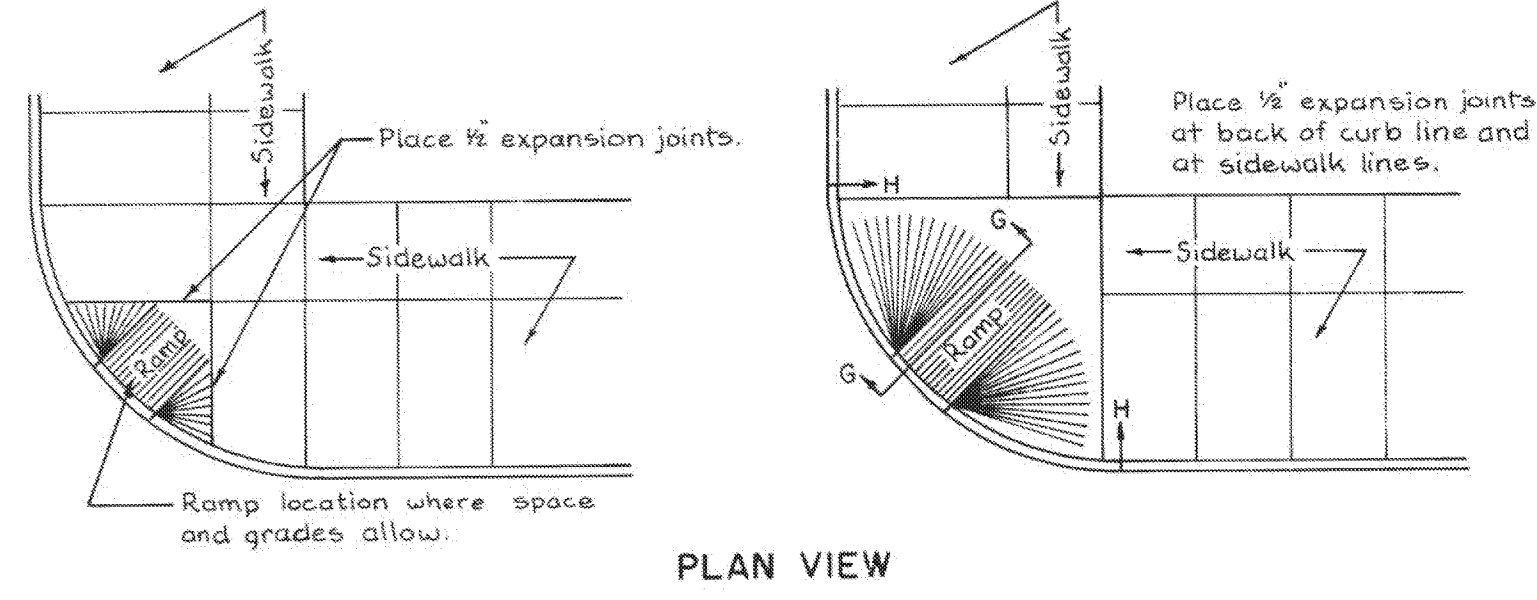

PLAN VIEW

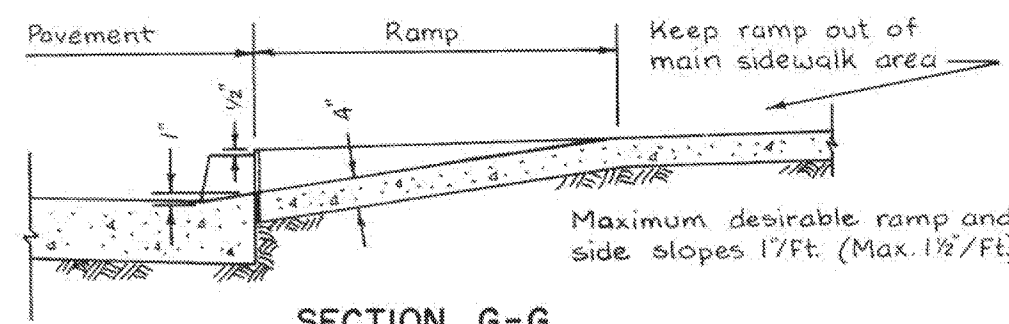

SECTION G-G

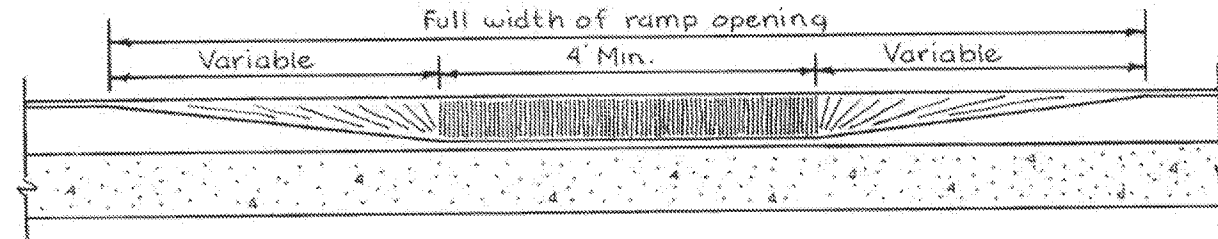

SECTION H-H

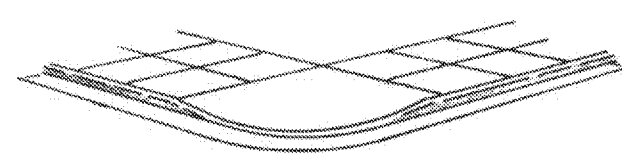

Note: This detail may also be used where the curb line is straight; for mid-block crosswalks.

SIDEWALK RAMP TYPE 3

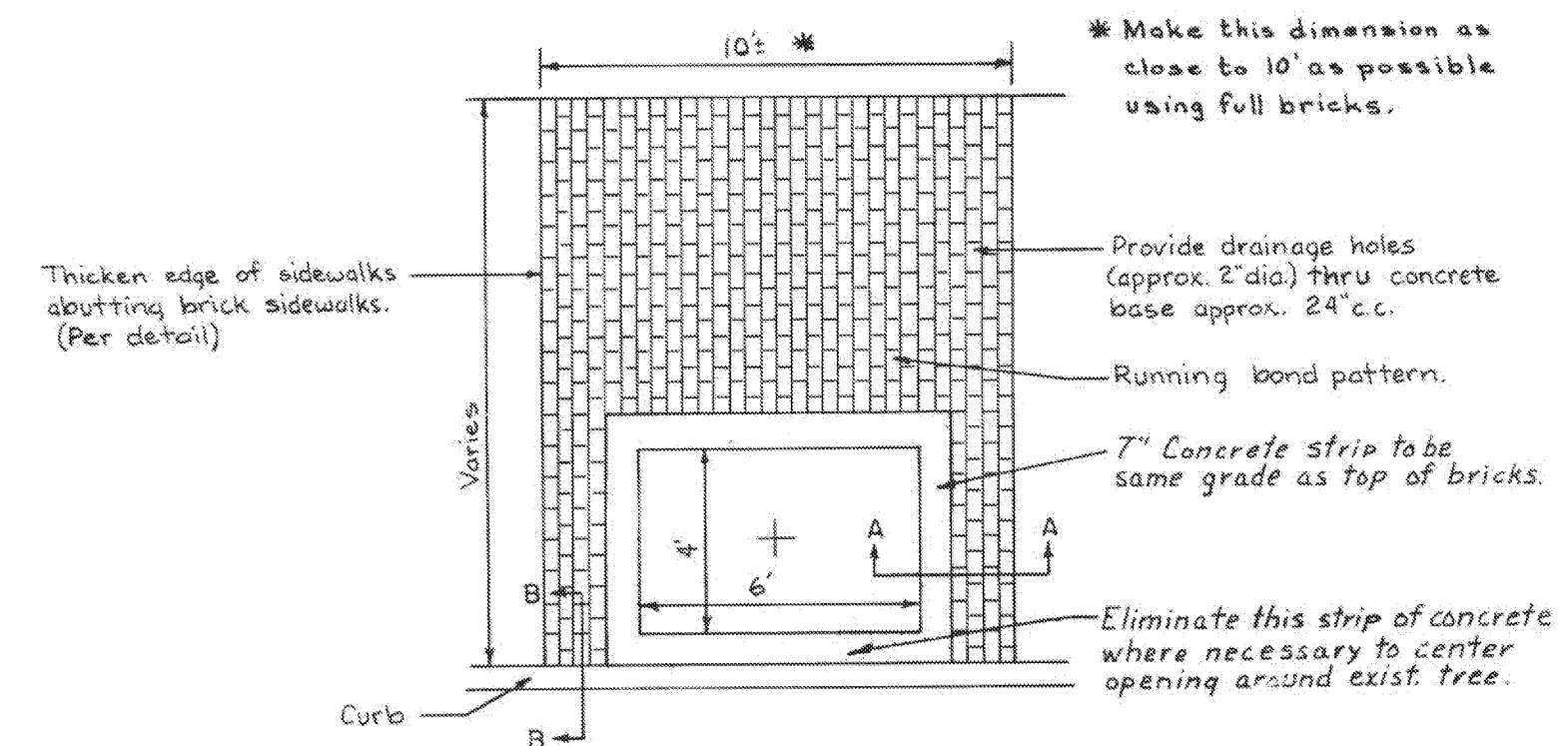

PLAN VIEW

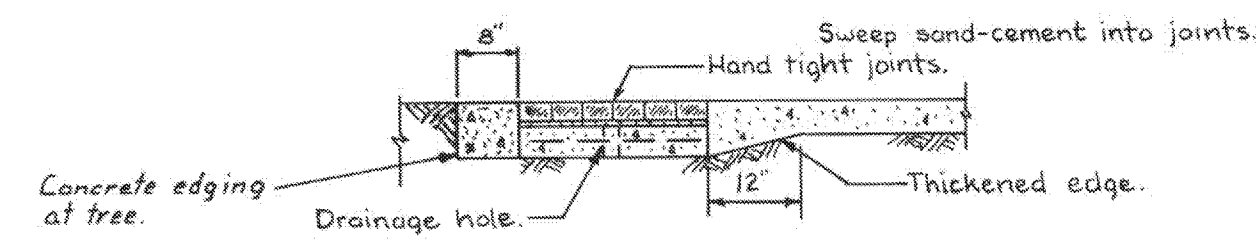

SECTION A-A

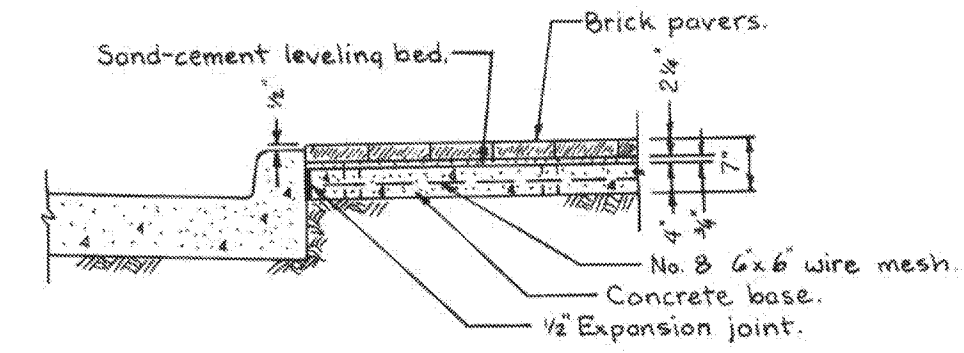

SECTION B-B

NOTES

1. Place 8" concrete edging along all unconfined brick edges. Where prairie film (stone epoxy) is to be installed by City, place temporary wood edging (1"x4" or larger).
2. Sand-cement to be 1 part cement for each 6 parts sand.
3. Brick pavers to be 4"x8"x2 1/4".
4. Brick panels to be centered (as measured parallel to curb) on existing or proposed trees.

BRICK PAVER SIDEWALK

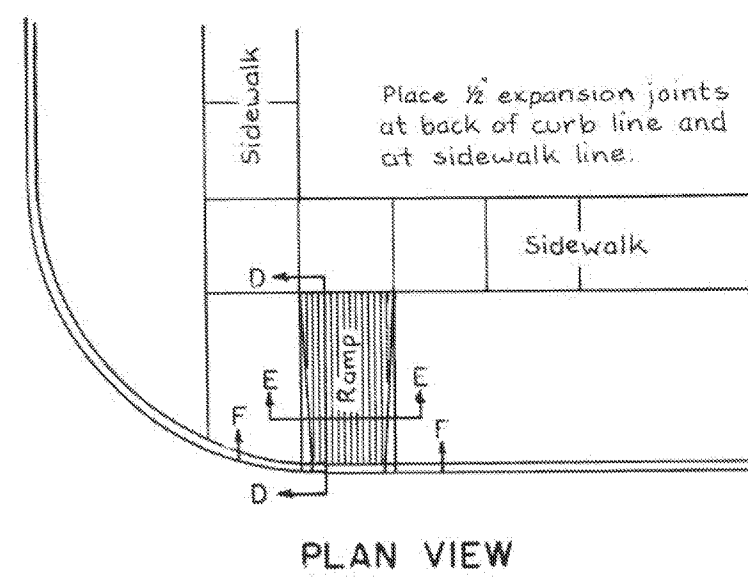

PLAN VIEW

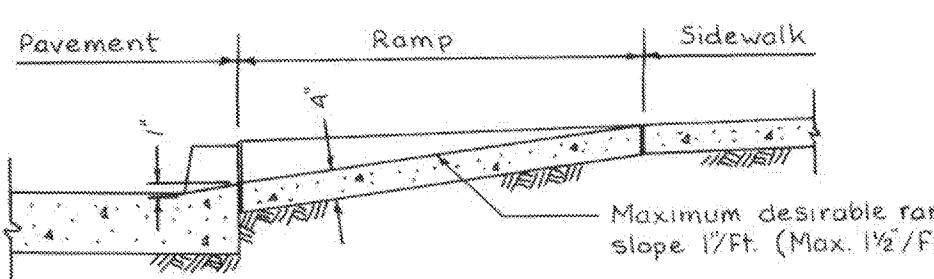

SECTION D-D

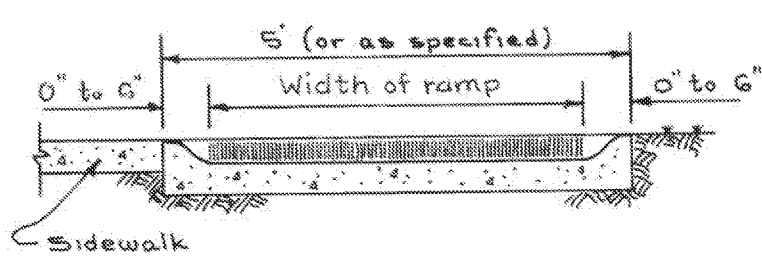

SECTION E-E

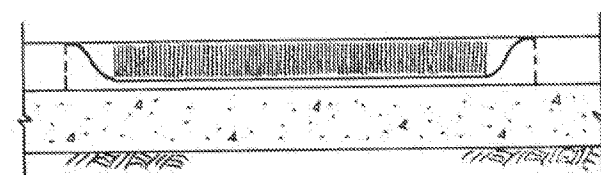

SECTION F-F

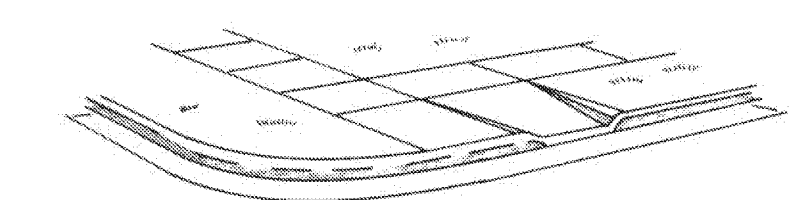

SIDEWALK RAMP TYPE 2

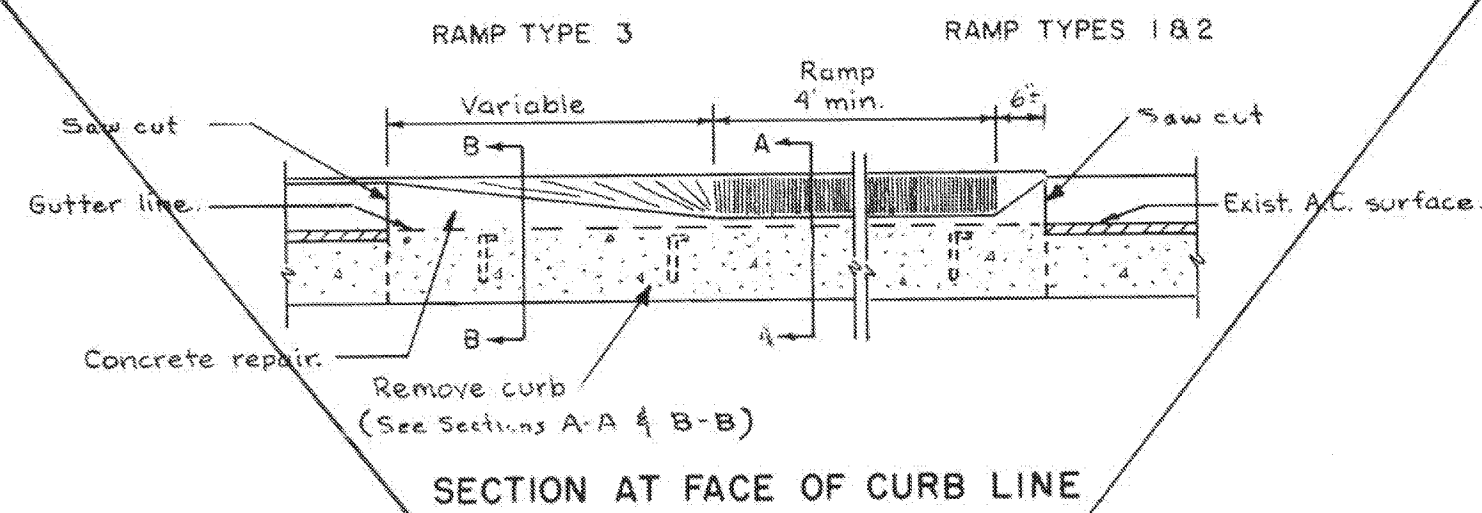

SECTION AT FACE OF CURB LINE

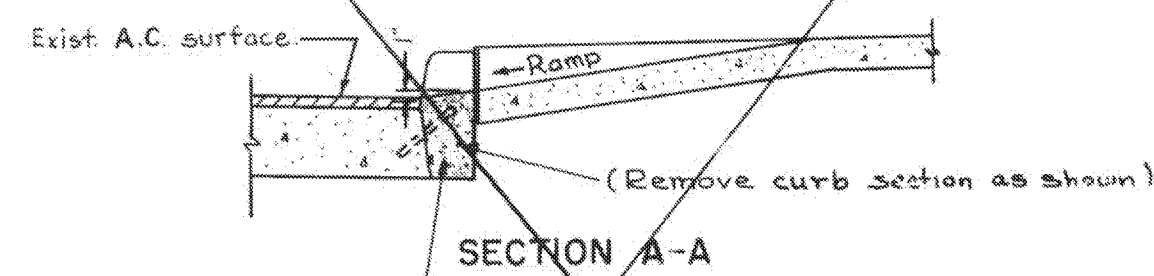

SECTION A-A

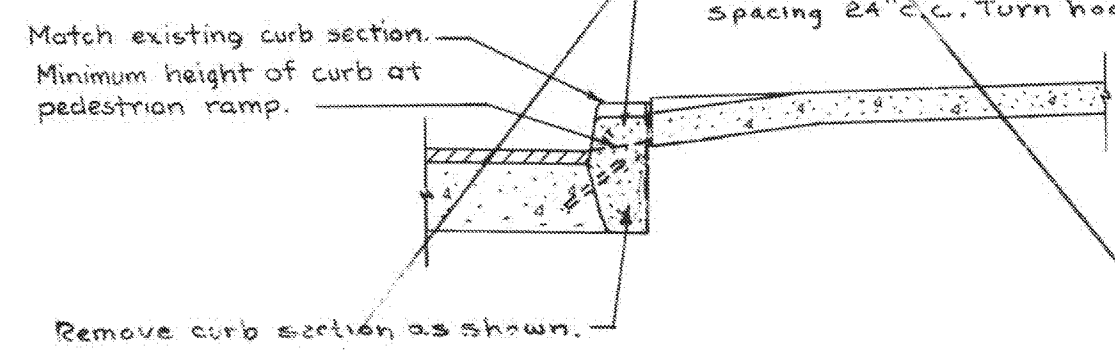

SECTION B-B

CURB REPAIR AT RAMPS (FOR ASPHALT SURFACED PAVEMENTS)

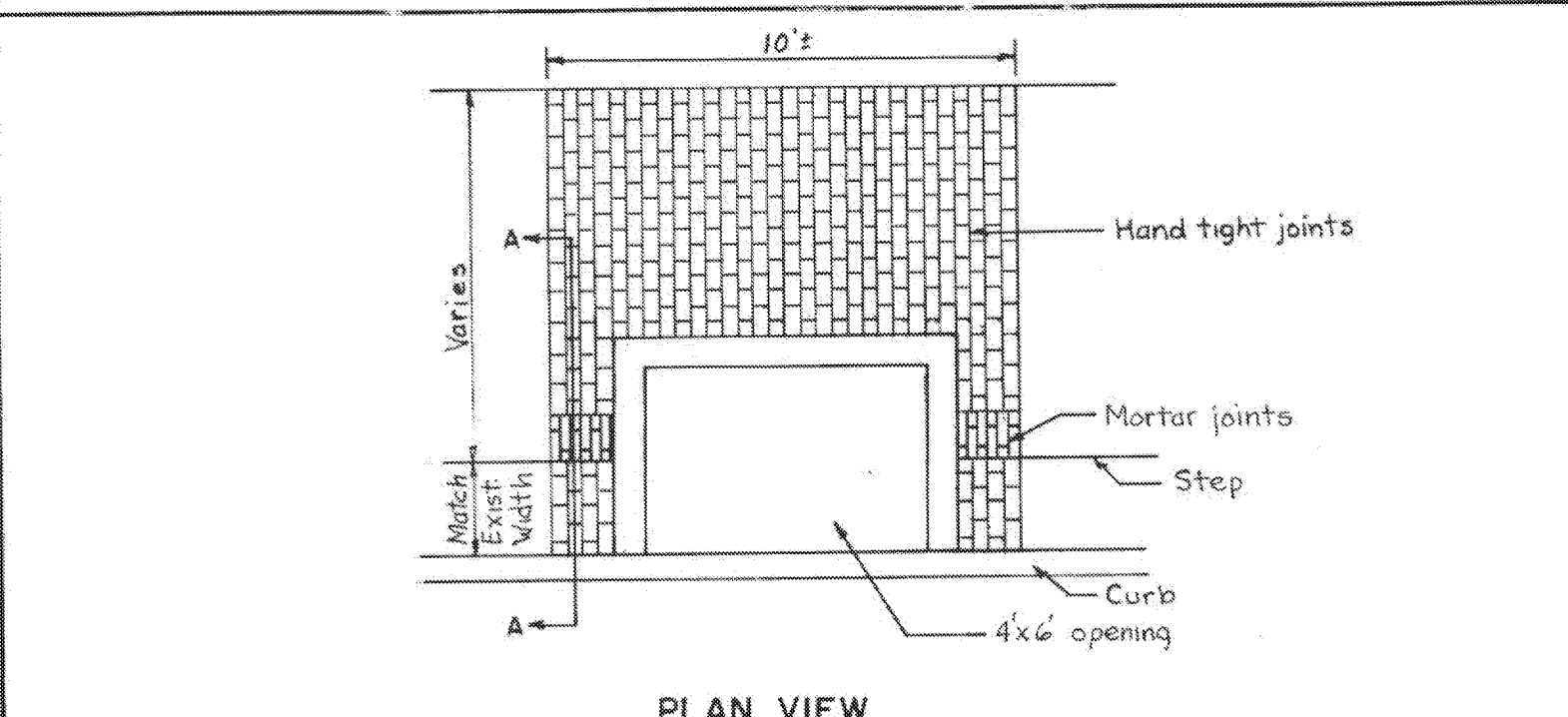

PLAN VIEW

NOTE: Brick panels with steps shall conform to standard detail 5 except as noted.

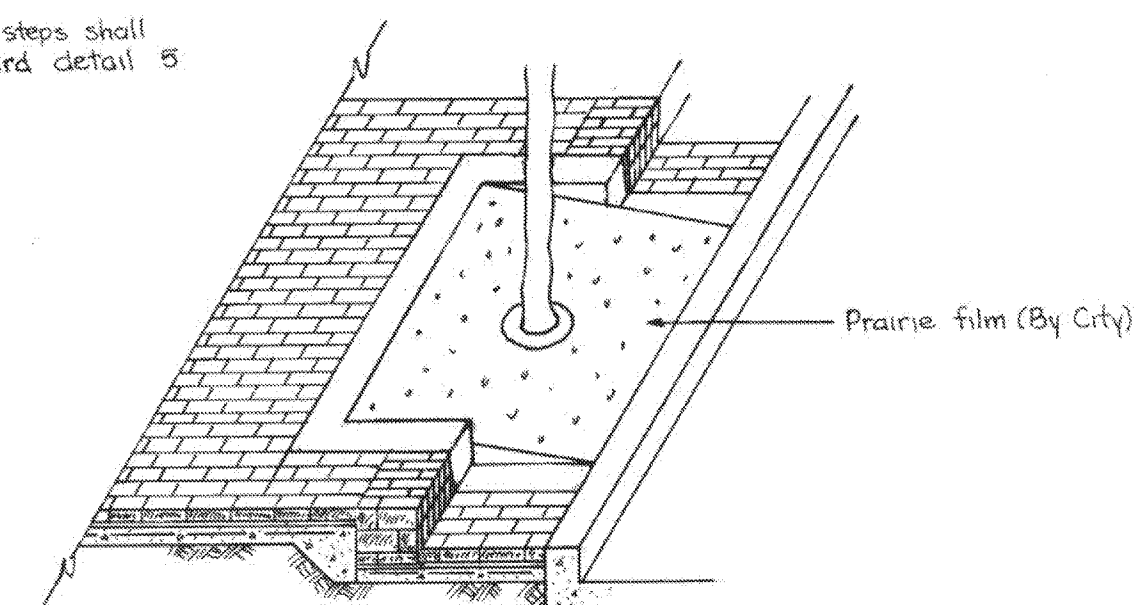

PERSPECTIVE VIEW

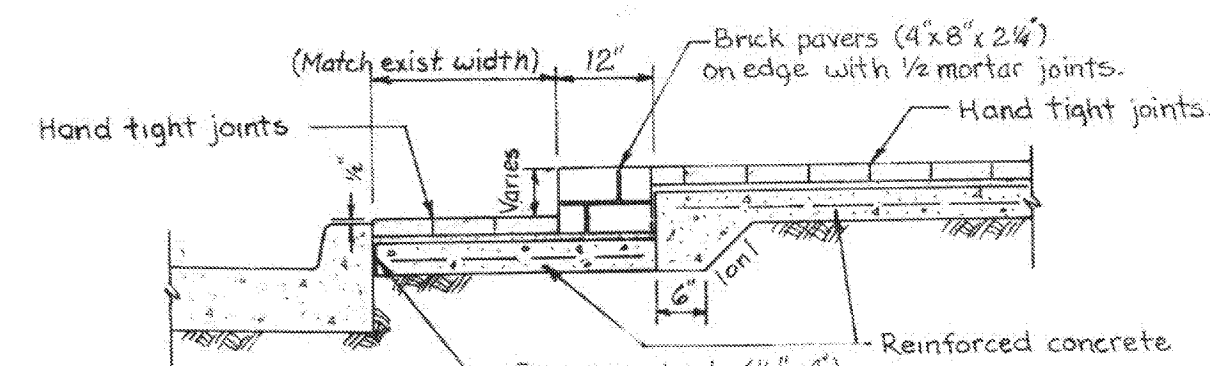

SECTION A-A

BRICK PANELS AT STEPS

NOTES FOR SIDEWALK RAMPS

1. Surface texture of the ramp shall be that obtained by a course brooming, transverse to the slope of the ramp.
2. Care shall be taken to assure a uniform grade on the ramp, free of sags and short grade changes.
3. If possible, drainage structures should not be placed in line with ramps. Except where existing drainage structures are being utilized in the new construction, location of the ramp should take precedence over location of drainage structure.
4. Use of sidewalk ramp type 2 shall be restricted to locations where it is not feasible to use type 1 or 3.
5. The normal gutter line profile shall be maintained through the area of the ramp.
6. Remove and replace concrete curb and gutter section at curb drops on non-asphalt surfaced gutters. Use existing joints or saw cut for joints. Saw cut at 18" from back of curb (for curved sections saw cut at minimum of 12" and at maximum of 24" from back of curb). Tie new concrete section to existing pavement with hook bolts or red heads at maximum of 24" c.c. (see detail 4).

REVISIONS		
NO.	DATE	BY
1.	8-25-76	RLB
2.	4-22-77	RLB
3.	6-28-78	RCS
4.	3-26-80	RCS
5.	9-17-82	JW

CITY OF BIRMINGHAM, MICHIGAN  
ENGINEERING DEPARTMENT

STANDARD DETAILS  
SIDEWALK RAMPS AND  
BRICK PAVER SIDEWALKS

SCALE: HORIZONTAL VERTICAL ACO. NO.

DRAWN BY RLB 3-9-76 APPROVED BY *H. J. Killeen*  
CHECKED BY FMS 3-31-76 CITY ENGINEER  
SHEET 1 OF 1 SHEETS DATE 3-9-76

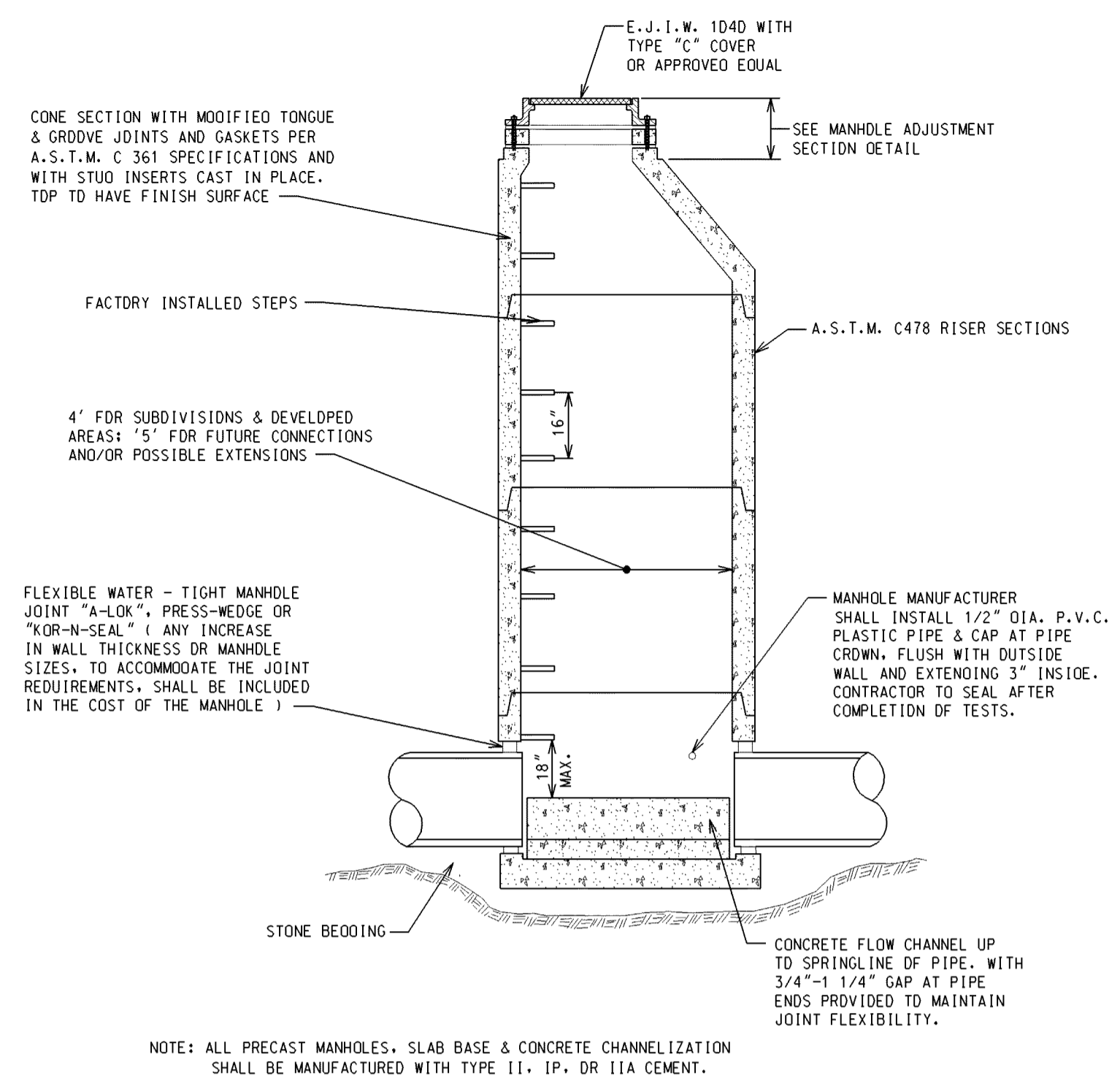

**SEWER MANHOLE**  
( 8" THRU 15" DIA. SEWERS )

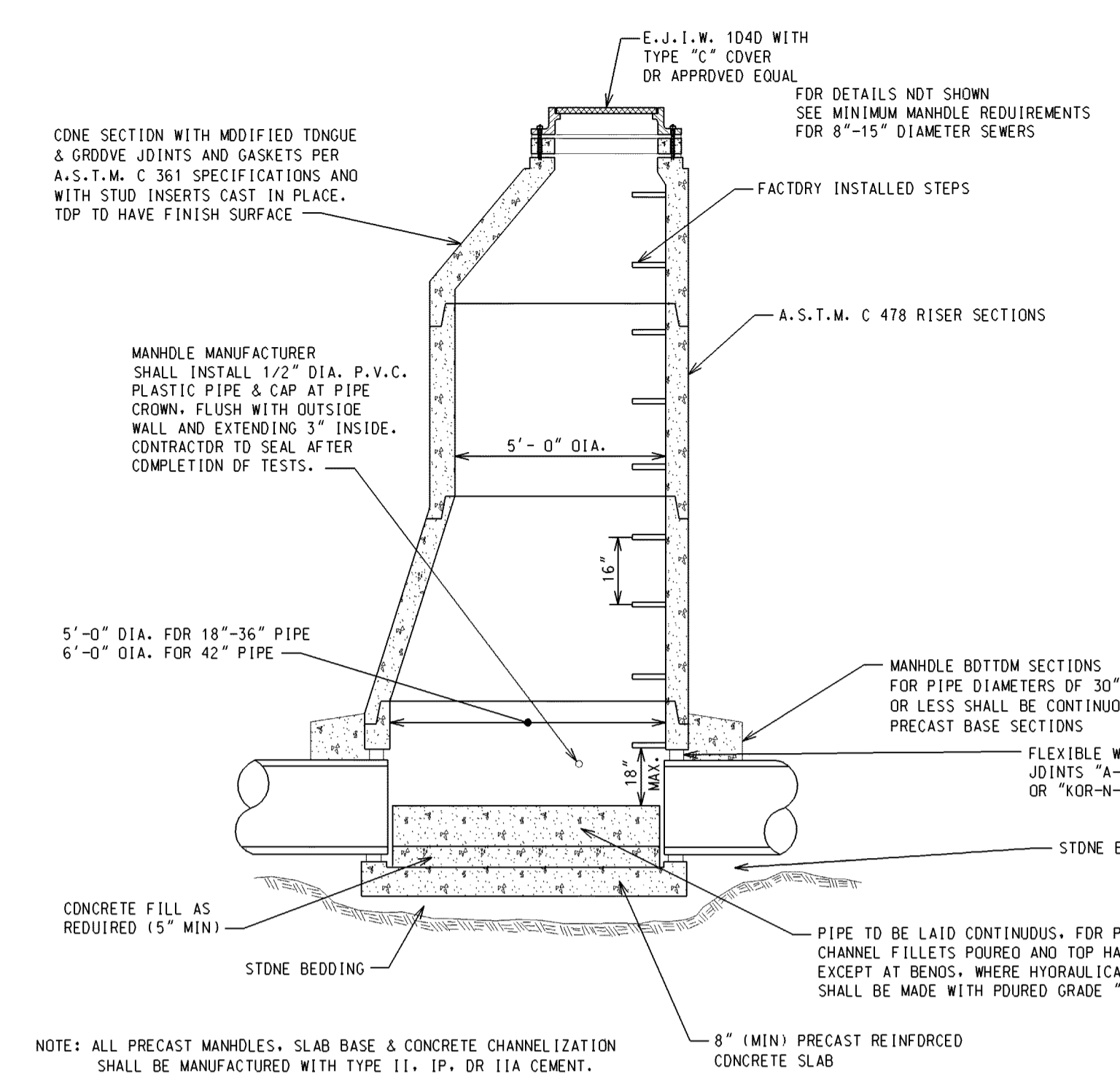

**SEWER MANHOLE**  
( 18" THRU 42" DIA. SEWERS )

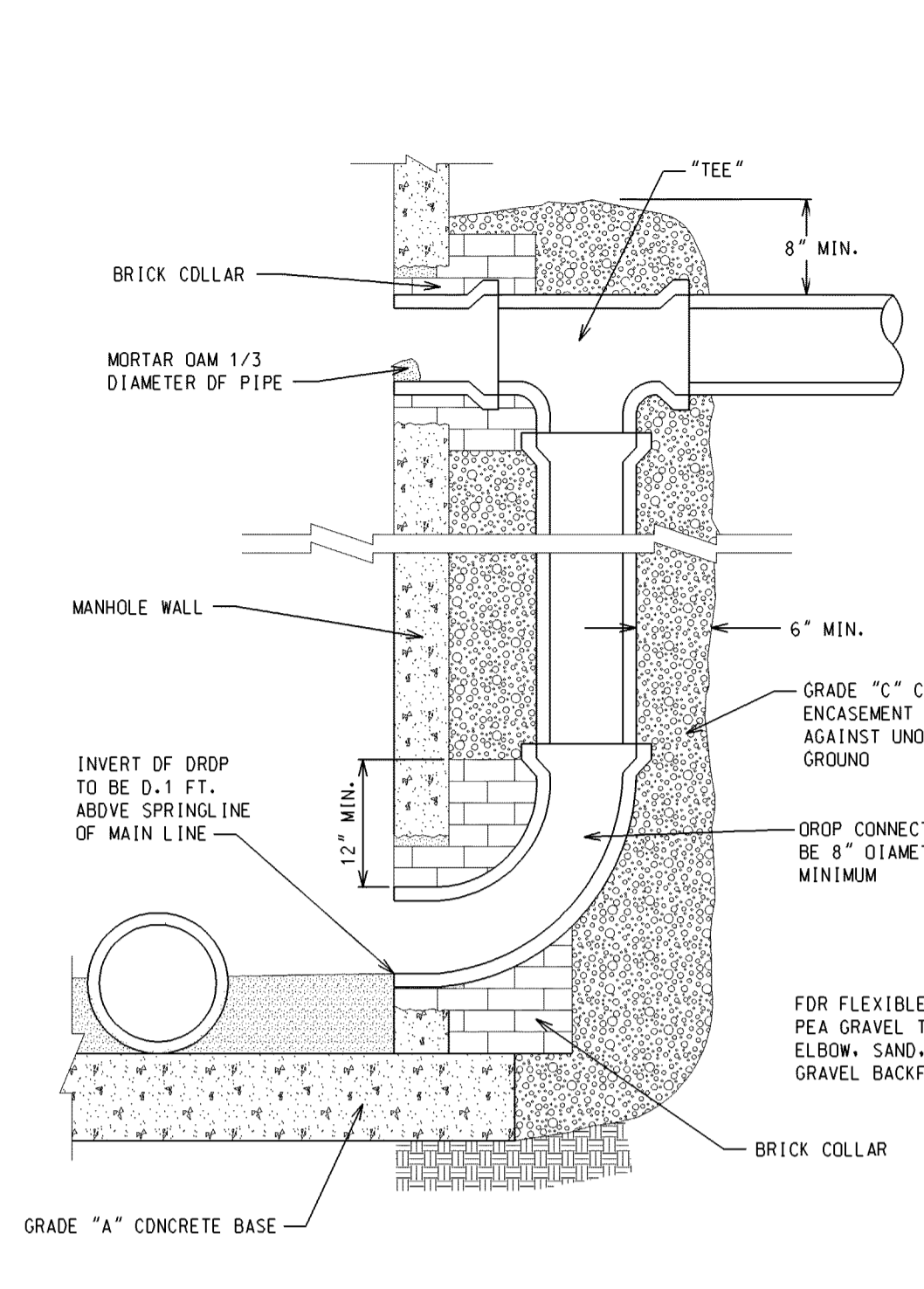

**EXTERNAL DROP CONNECTION**

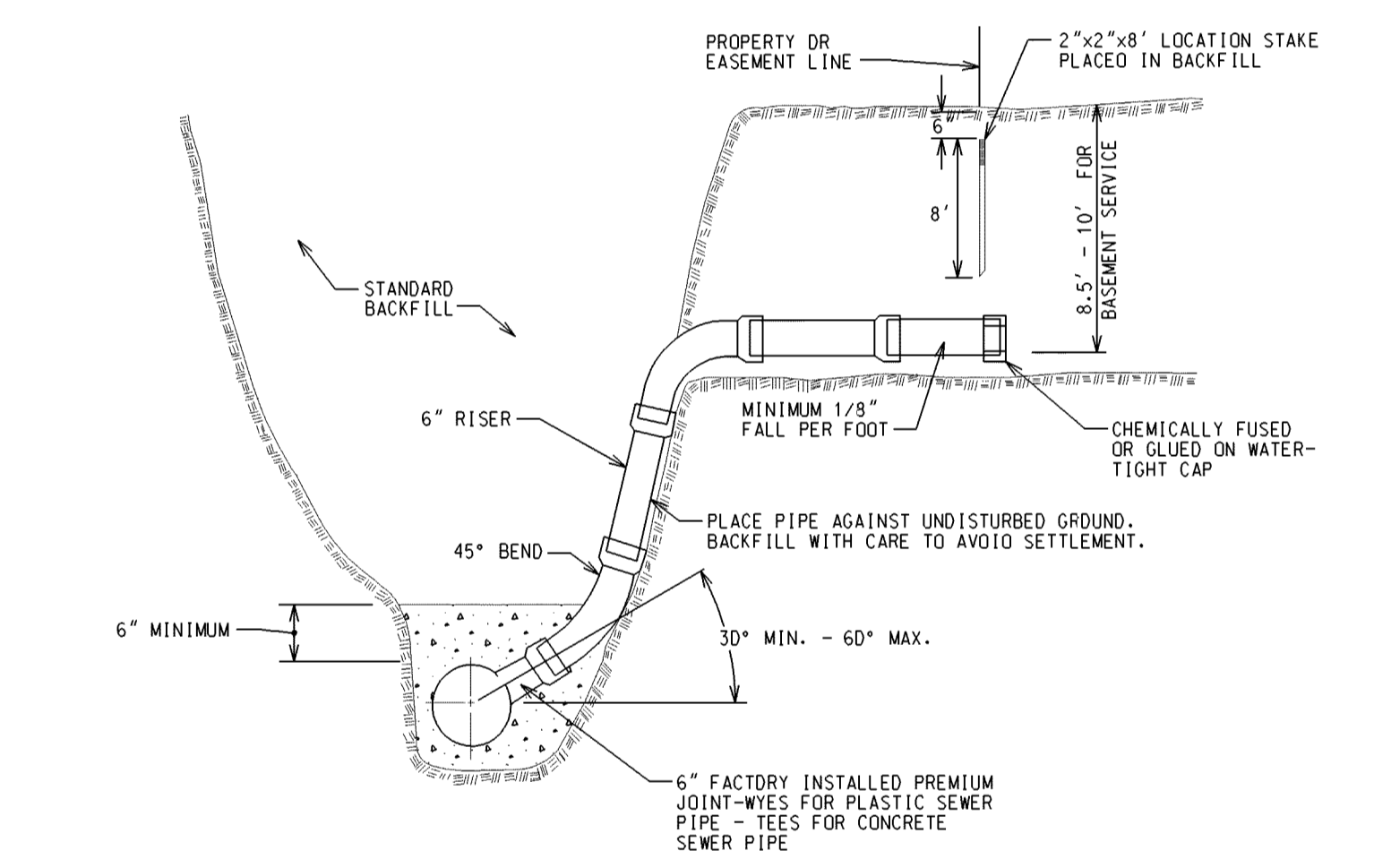
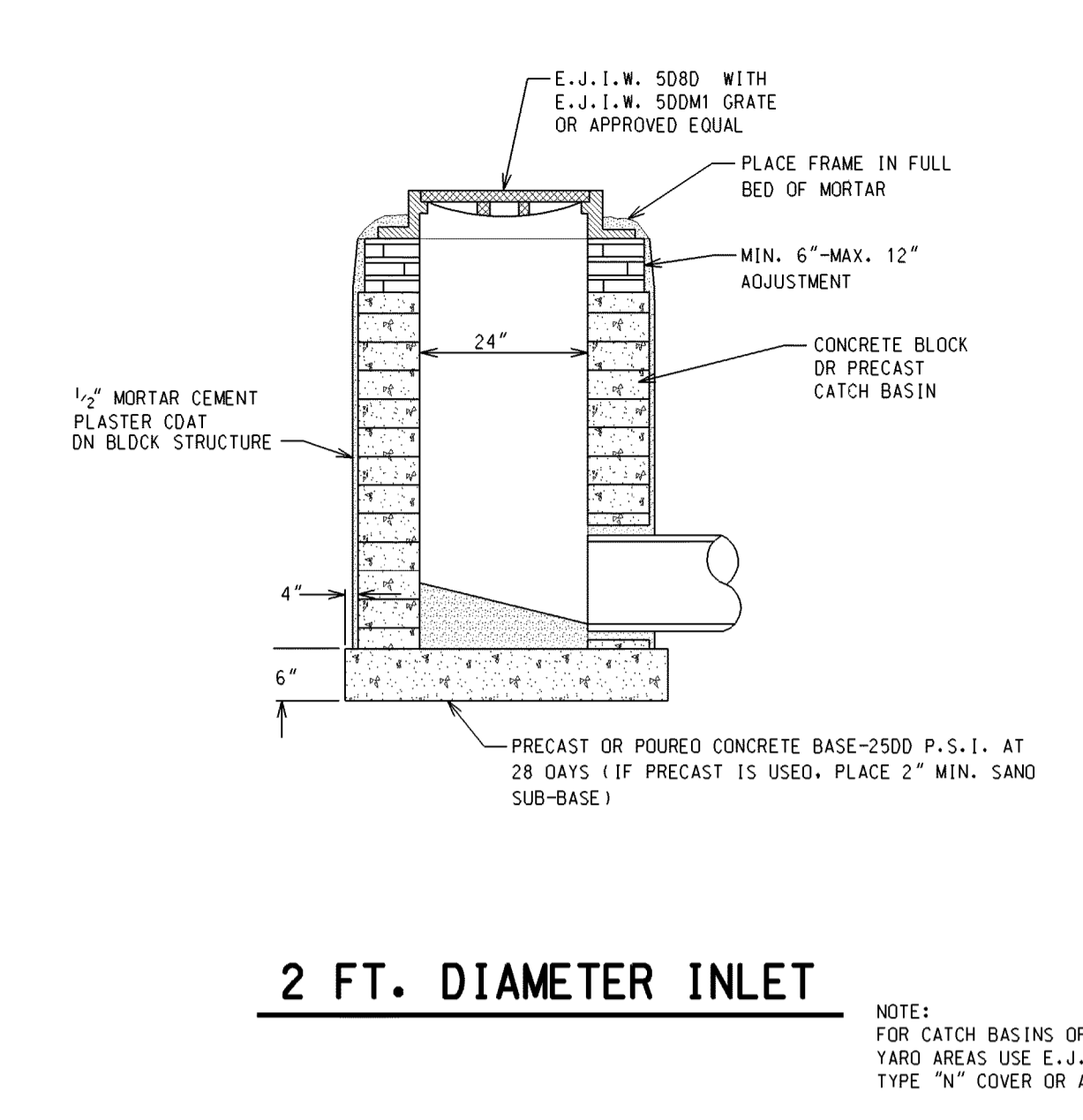

**BUILDING LEAD DETAIL**  
0" - 15" COVER

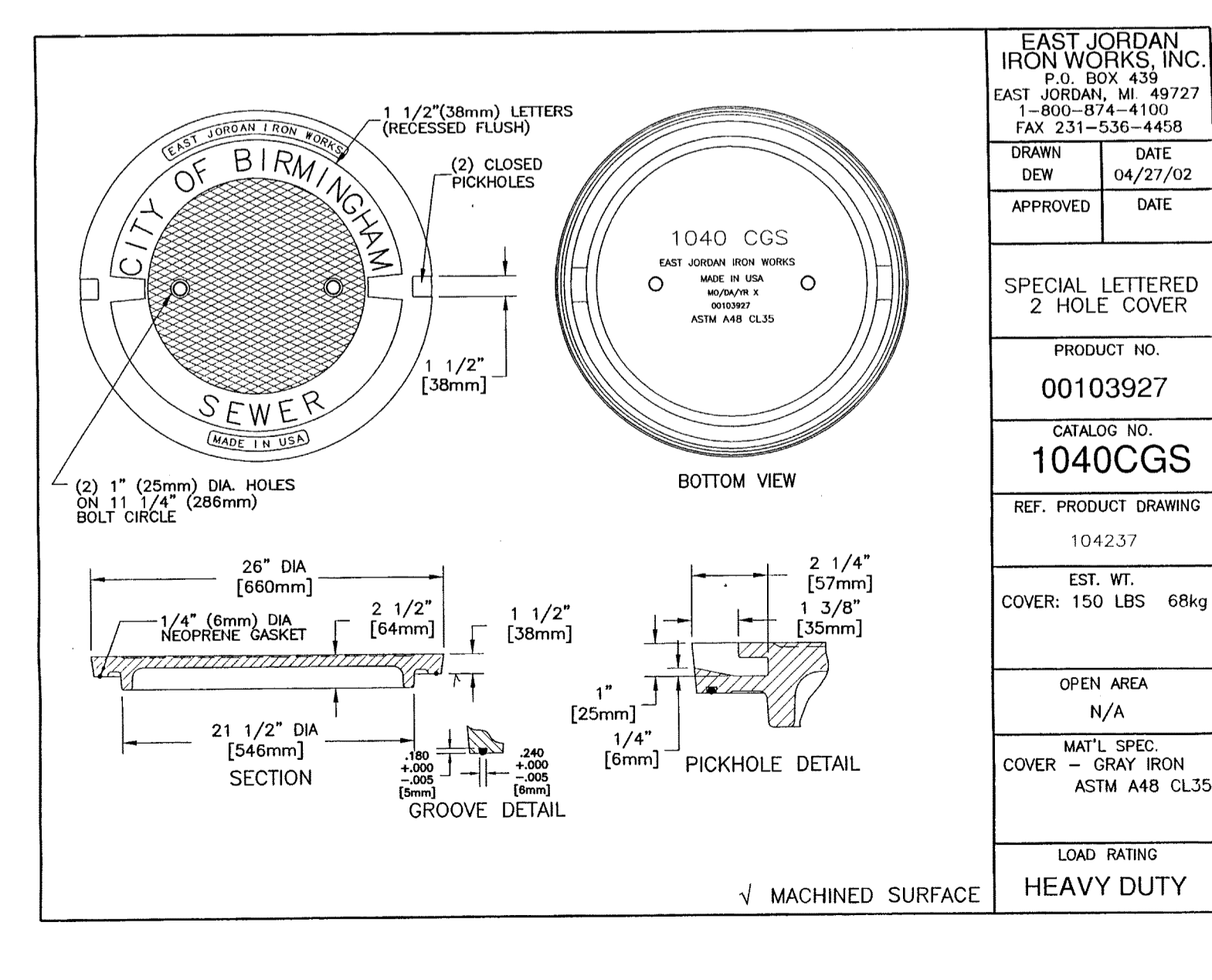
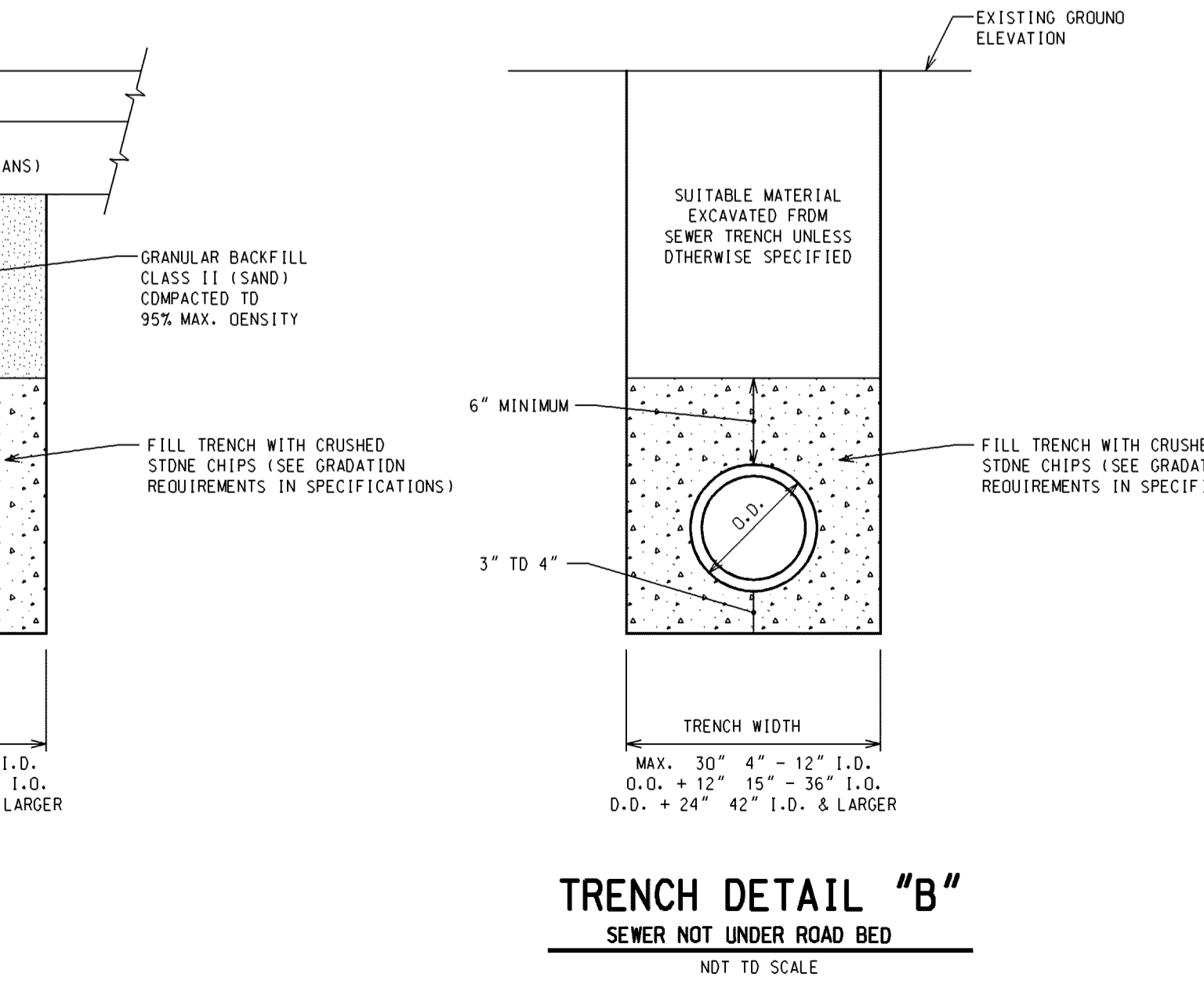
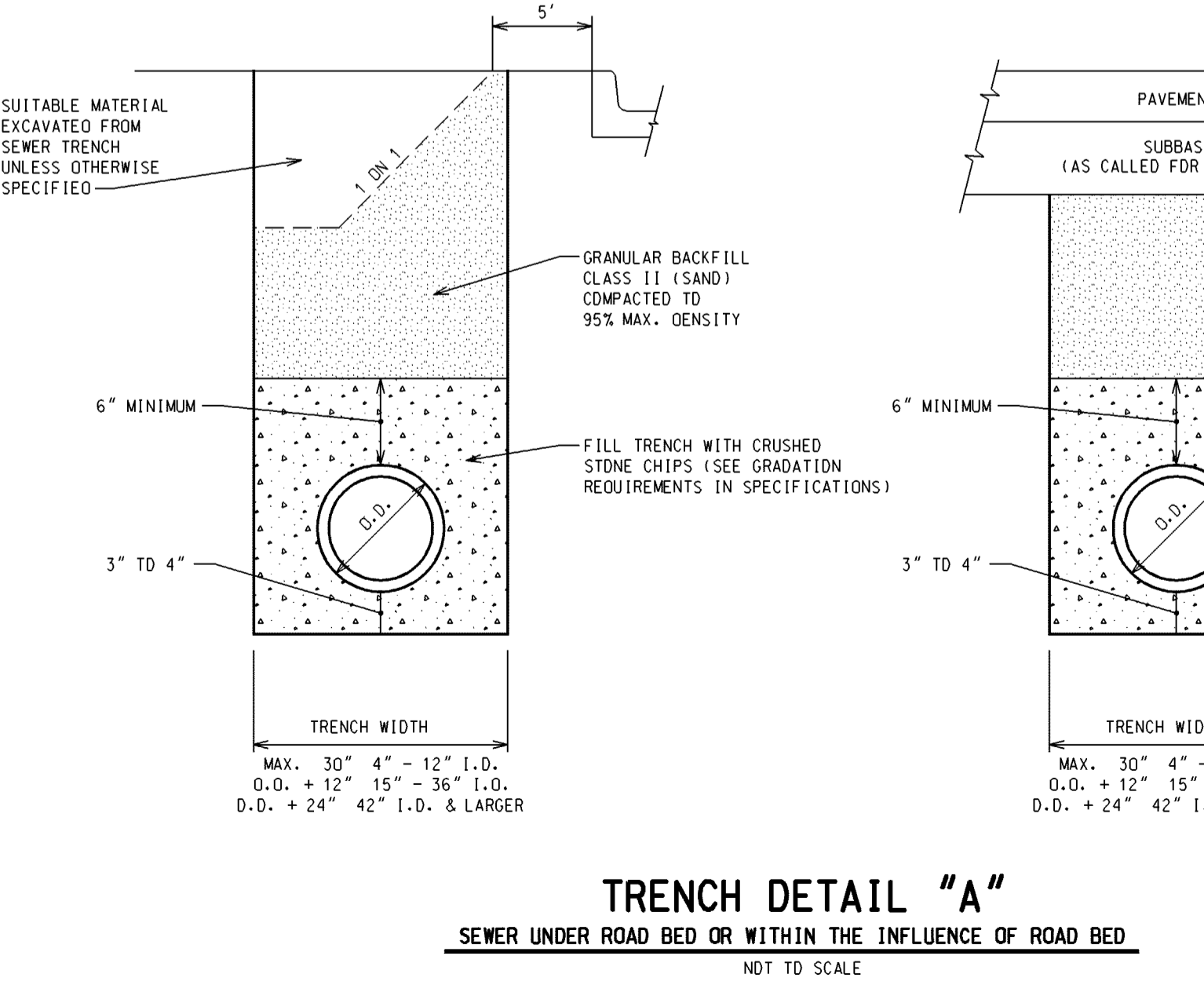
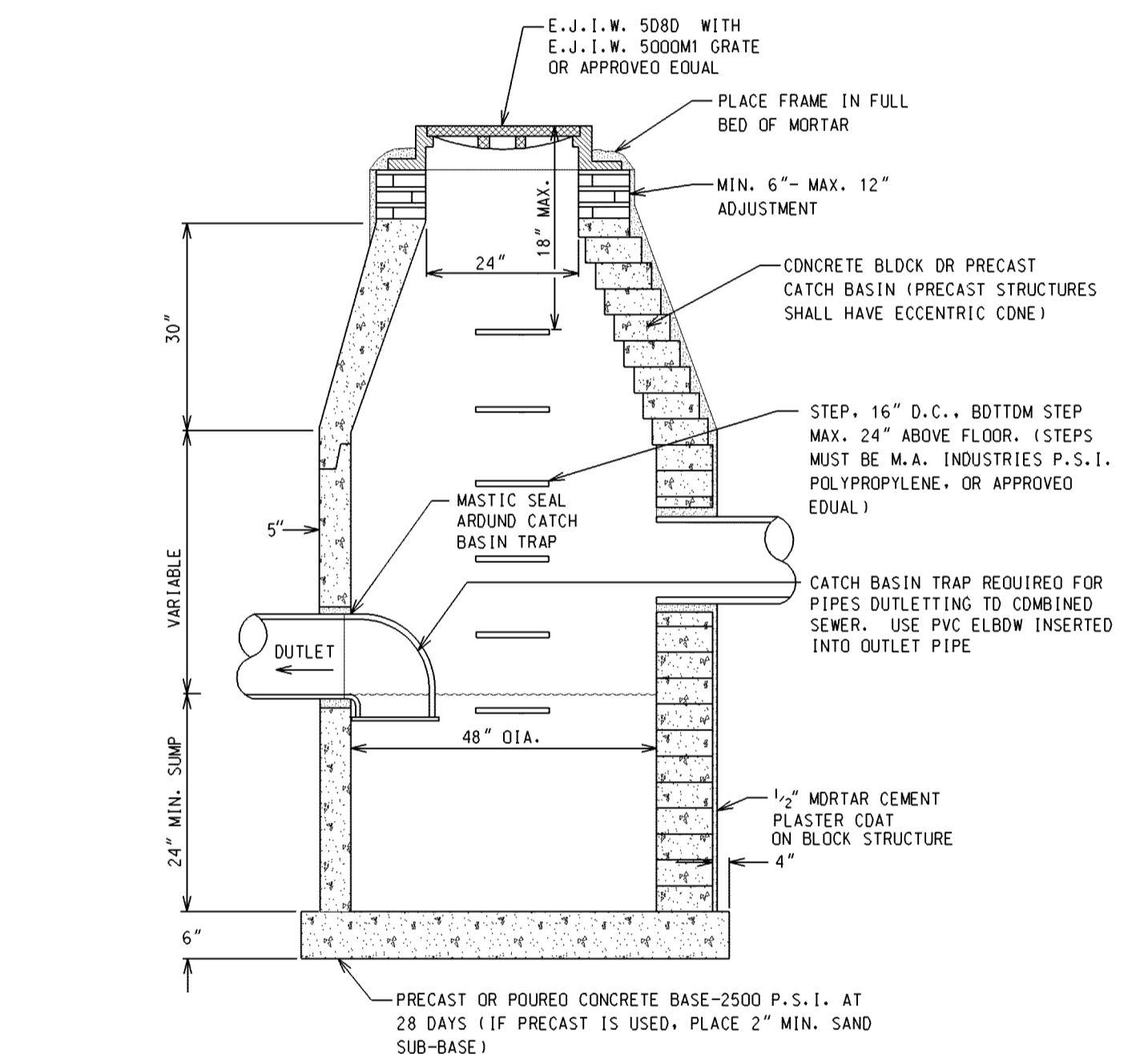
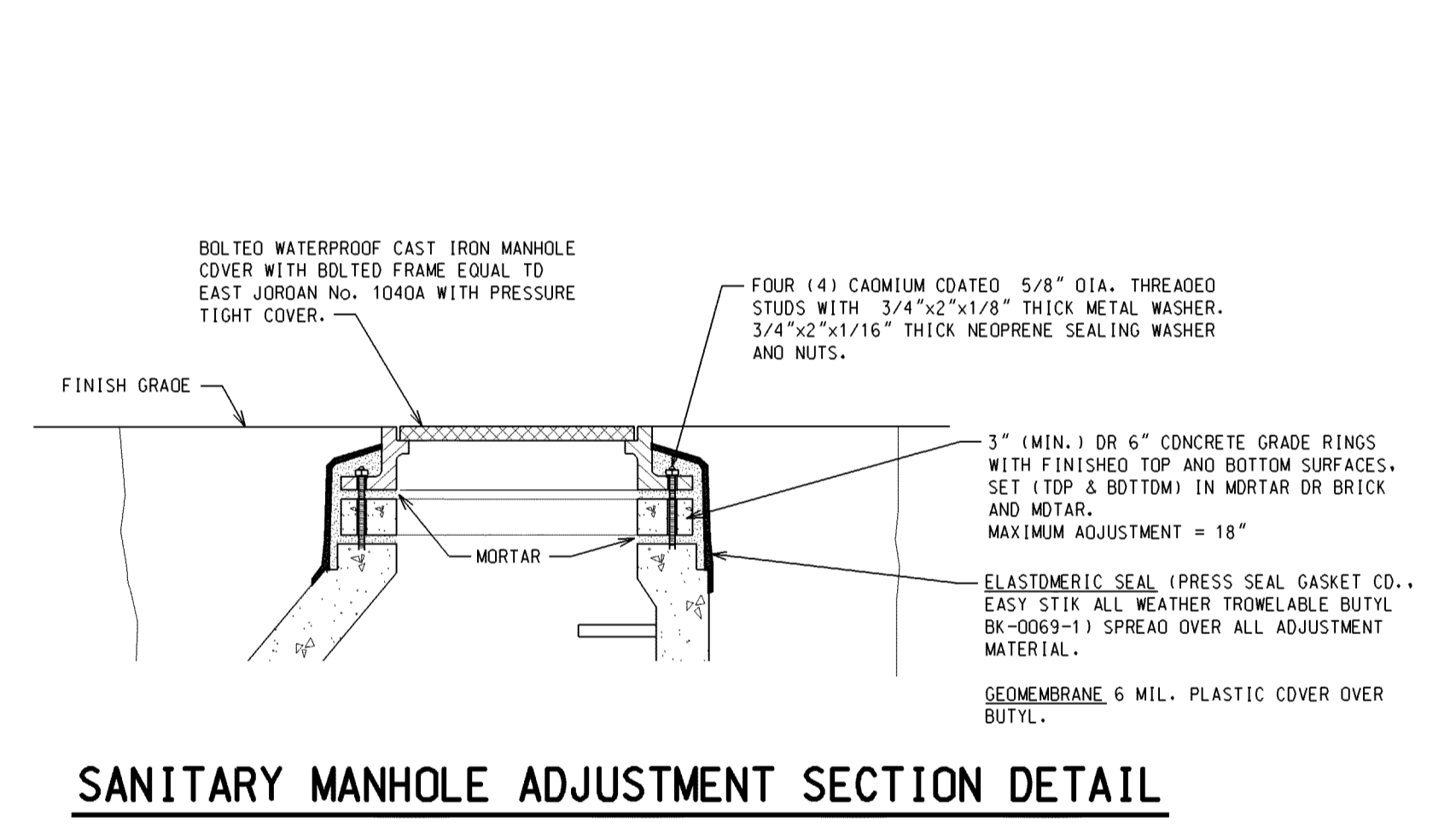
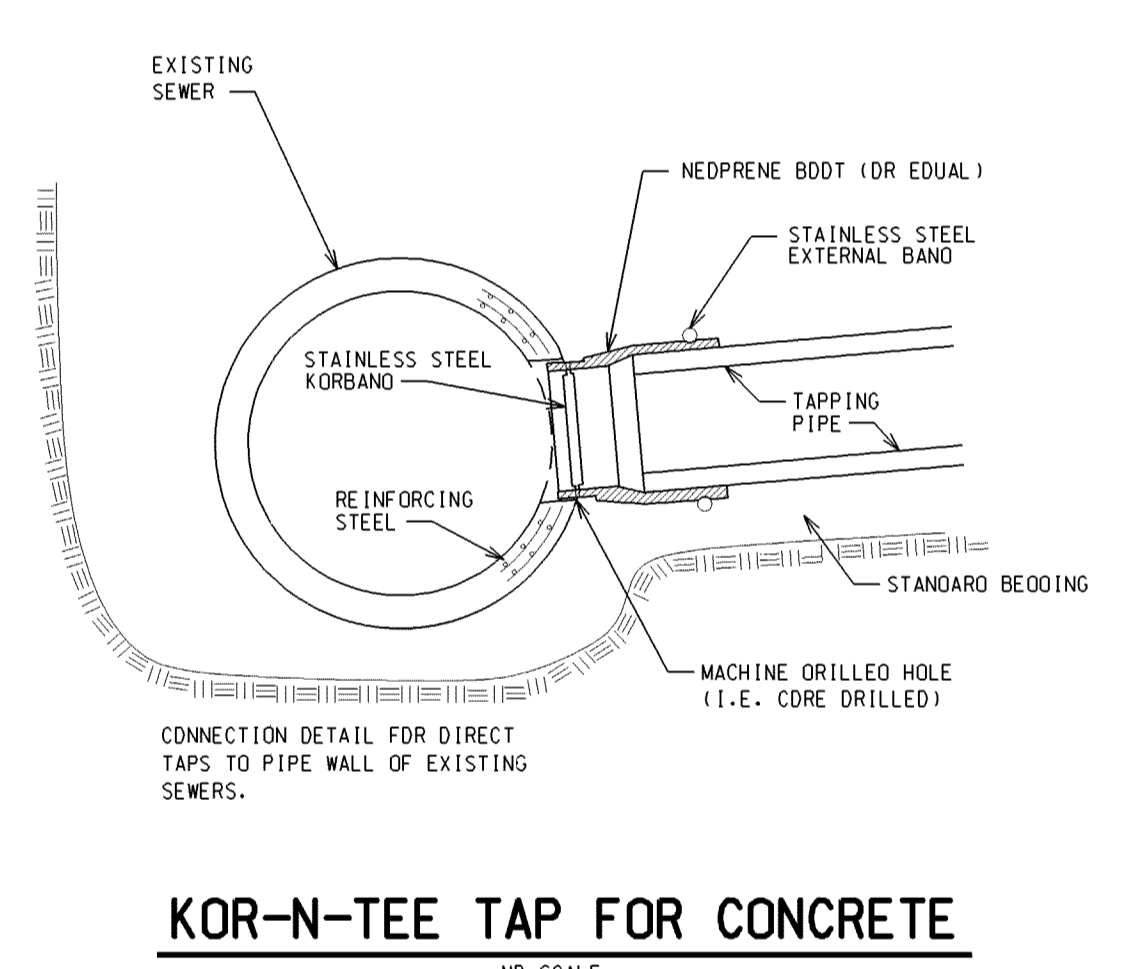

**City of Birmingham**  
A Vibrant Community

151 MARTIN STREET BIRMINGHAM, MICHIGAN 48102

**SEWER STANDARD DETAILS**

DATE:	ADDITION AND/OR REVISION	DRAWN	PROJECT NO.	SHEET NO.
		DESIGNED	DATE	JANUARY 2007
		APPROVED	SCALE	

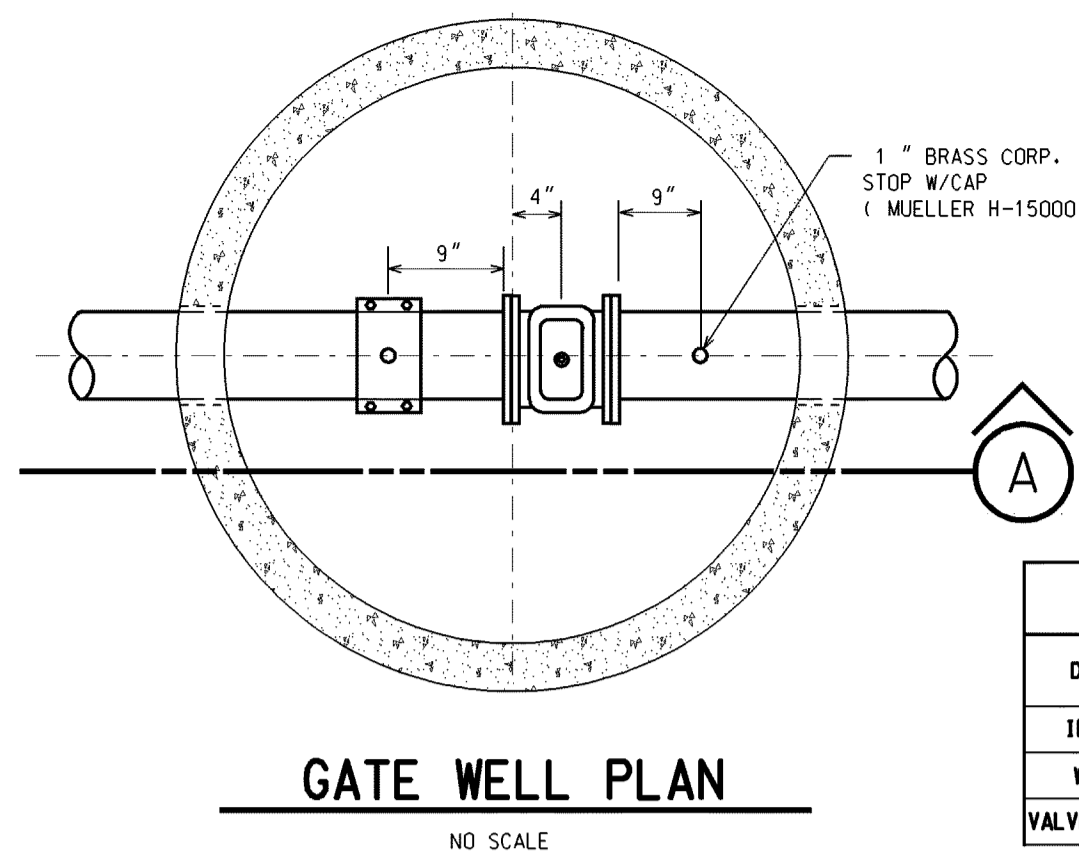

**GATE WELL SCHEDULE**

DESCRIPTION	DIM.	PIPE DIA. INCHES
INSIDE DIA.	A	6" & 8" 12" 16"
WALL THICK.	B	5" 7" 7"
VALVE BLOCK THICK.	C	4" 4" 4"

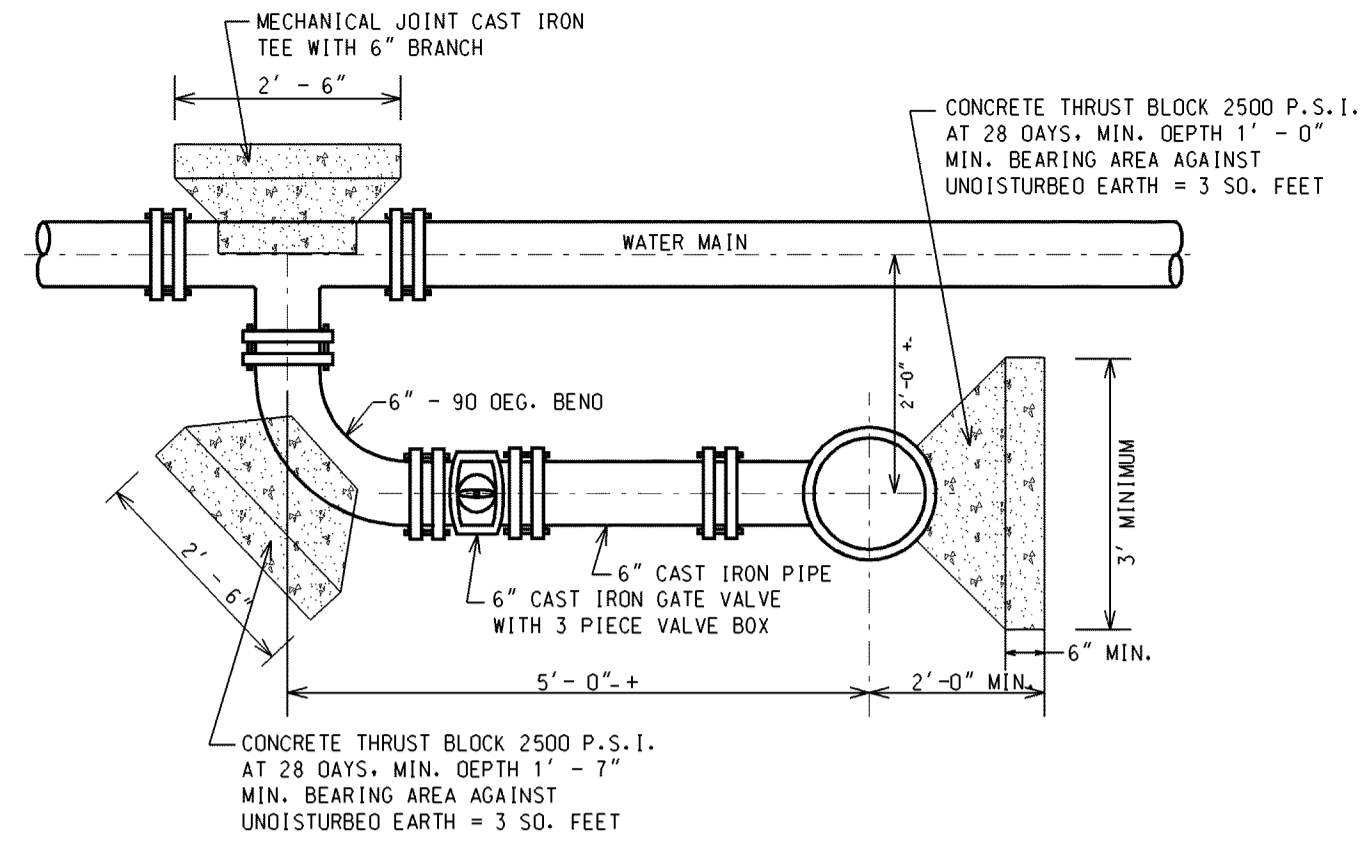
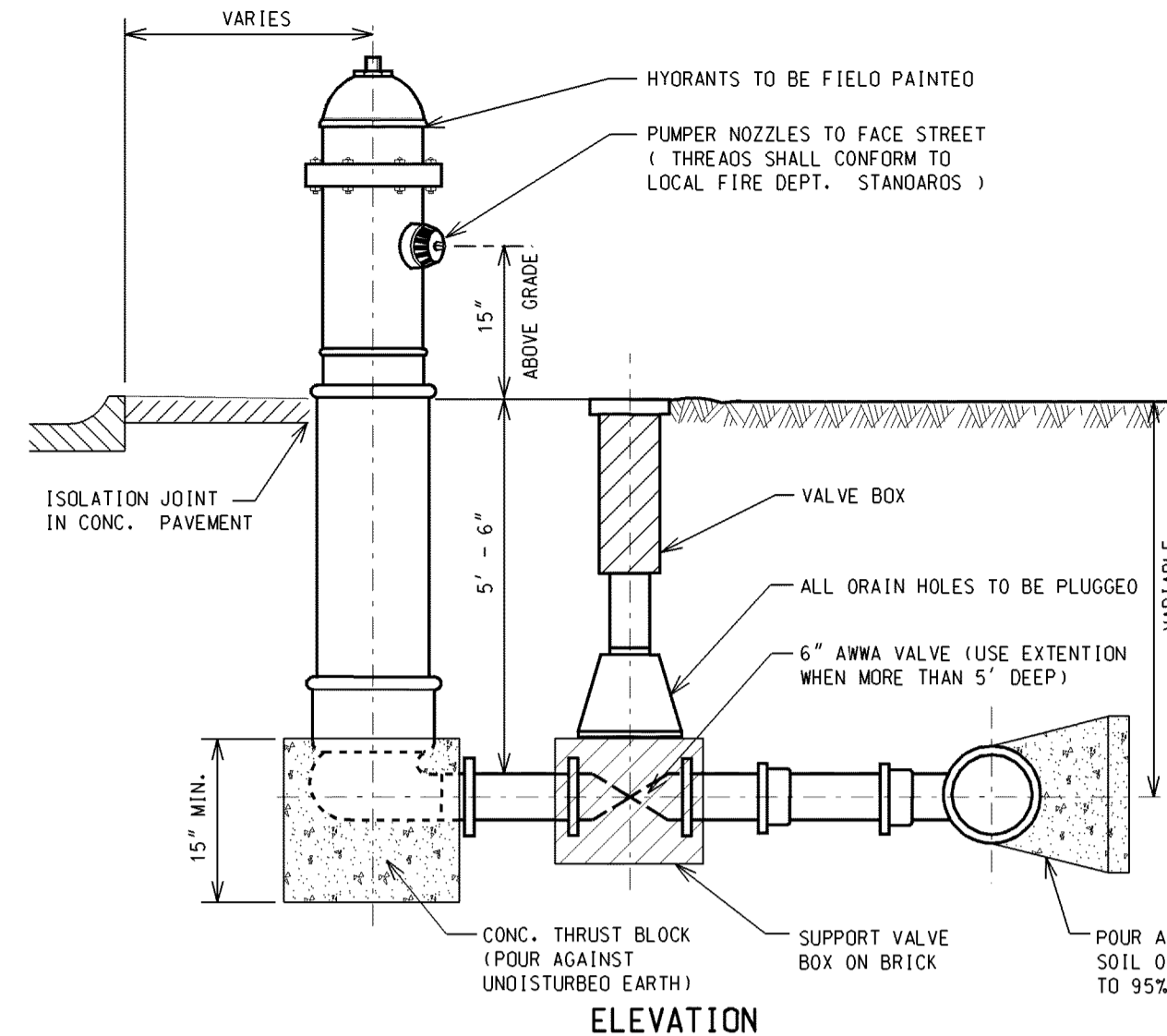
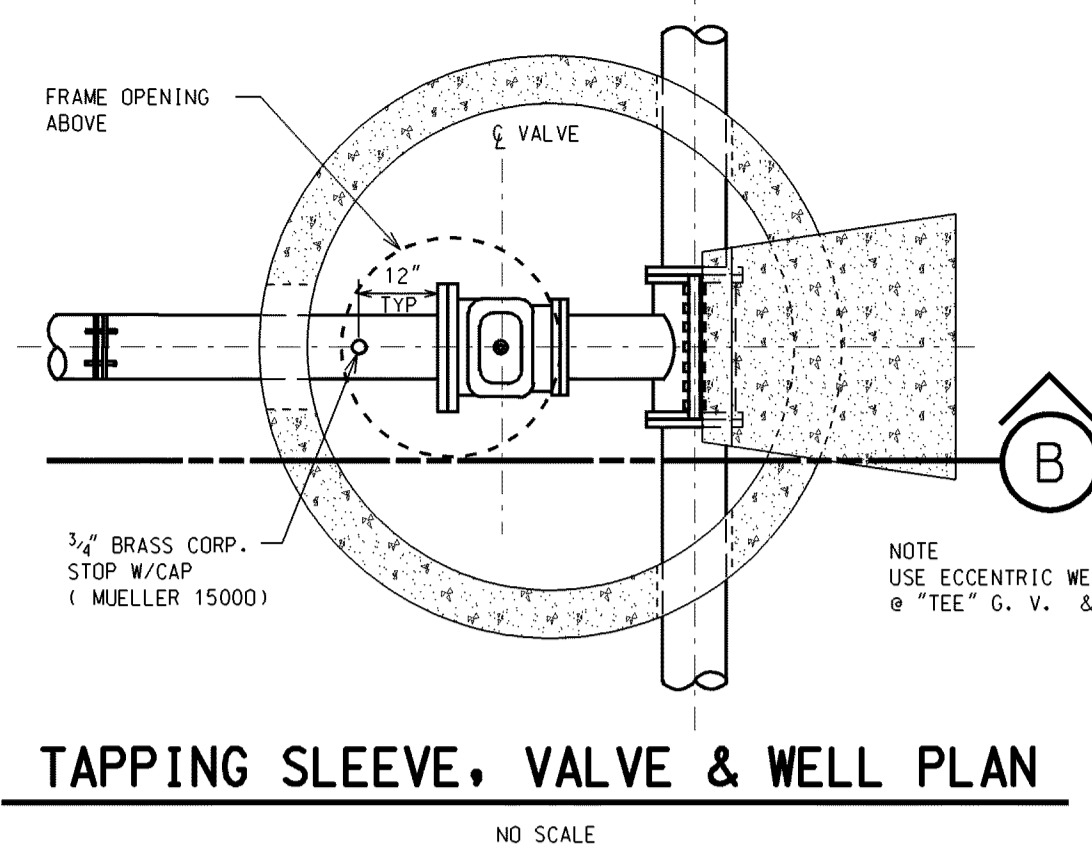

**"L" HYDRANT CONNECTION**  
NO SCALE  
W-9

NOTE: FOR CONSTRUCTION OF NEW FIRE HYDRANT TO EXISTING "LIVE" WATERMAIN, USE 6" TAPPING SLEEVE VALVE & BOX TO MAKE CONNECTION, AND DELETE "6" CAST IRON GATE VALVE WITH 3 PIECE VALVE" AS SHOWN ON DETAIL.

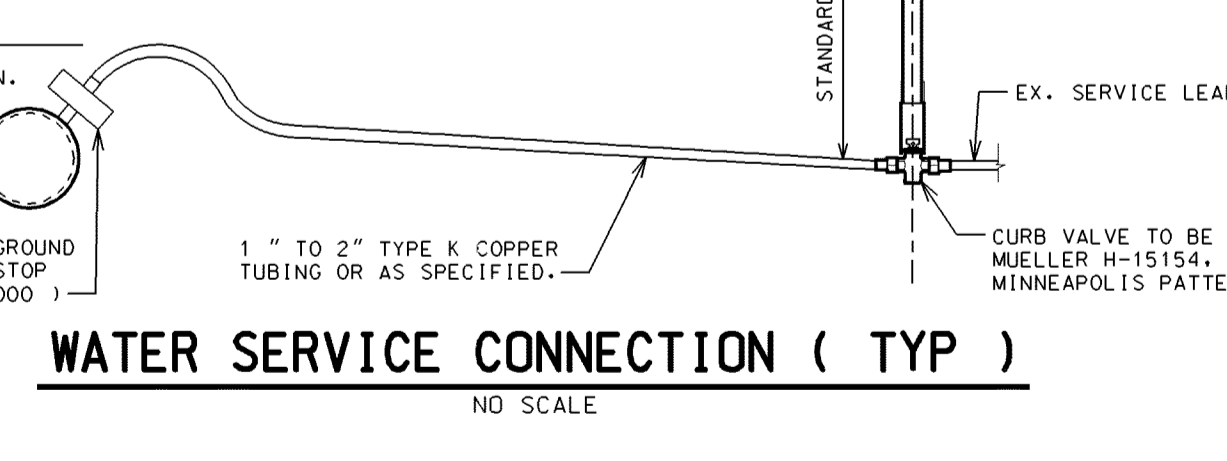
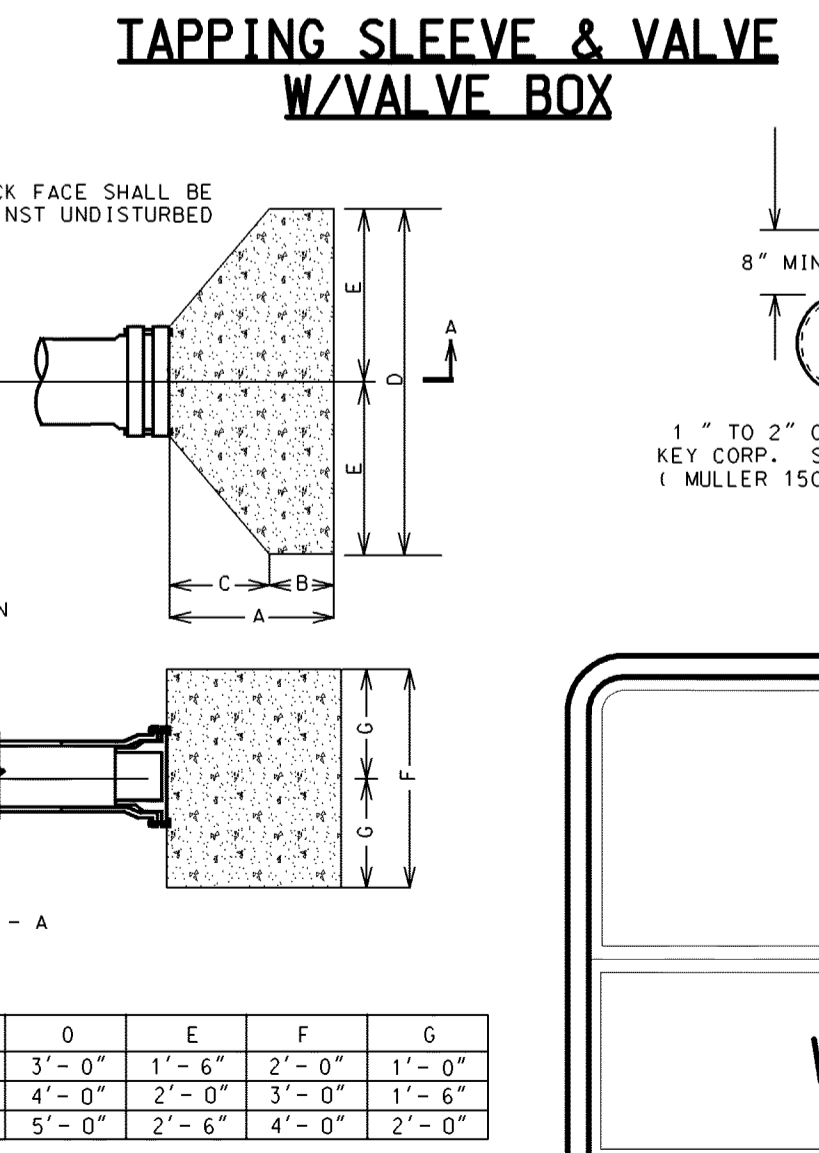
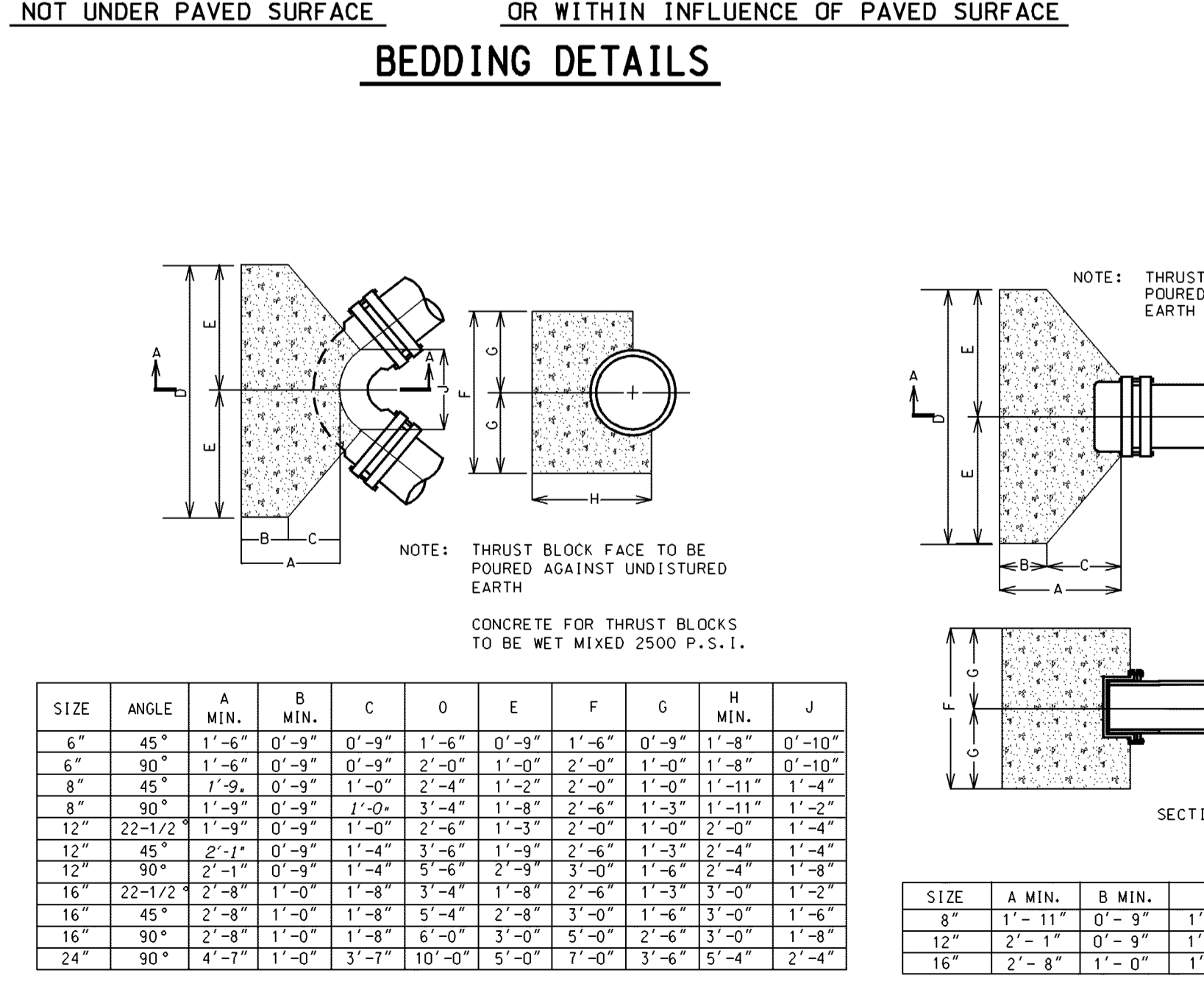
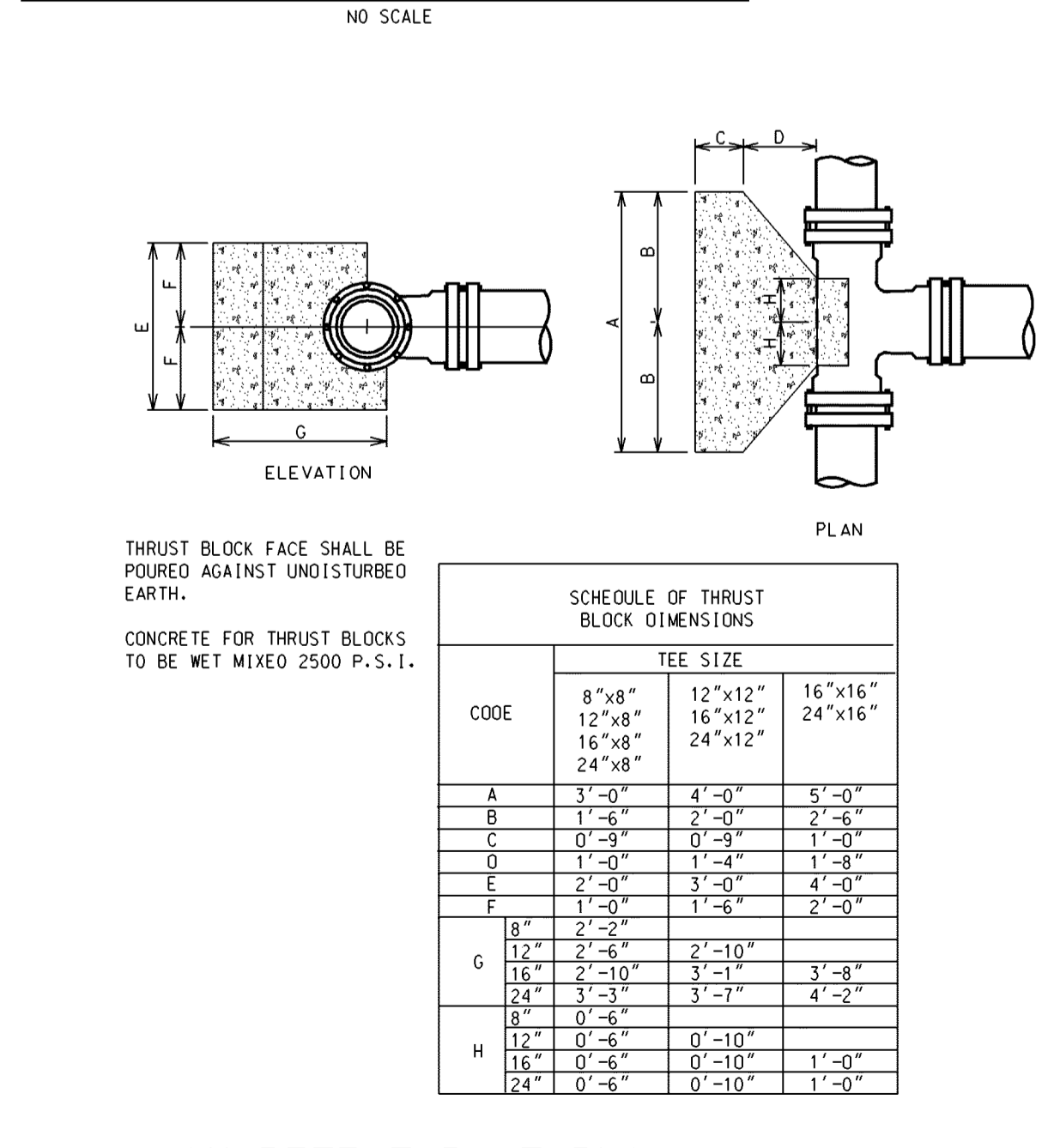
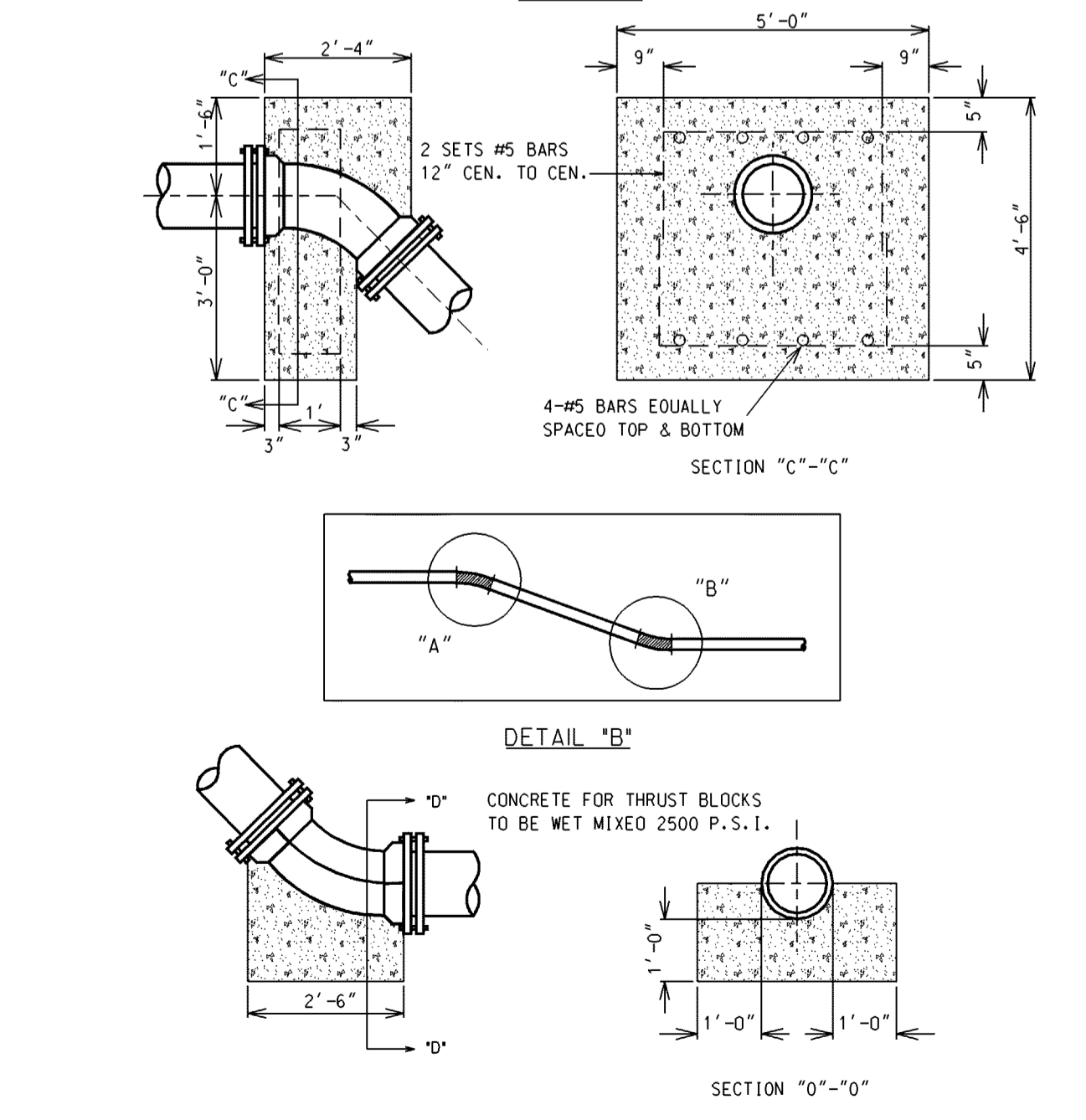
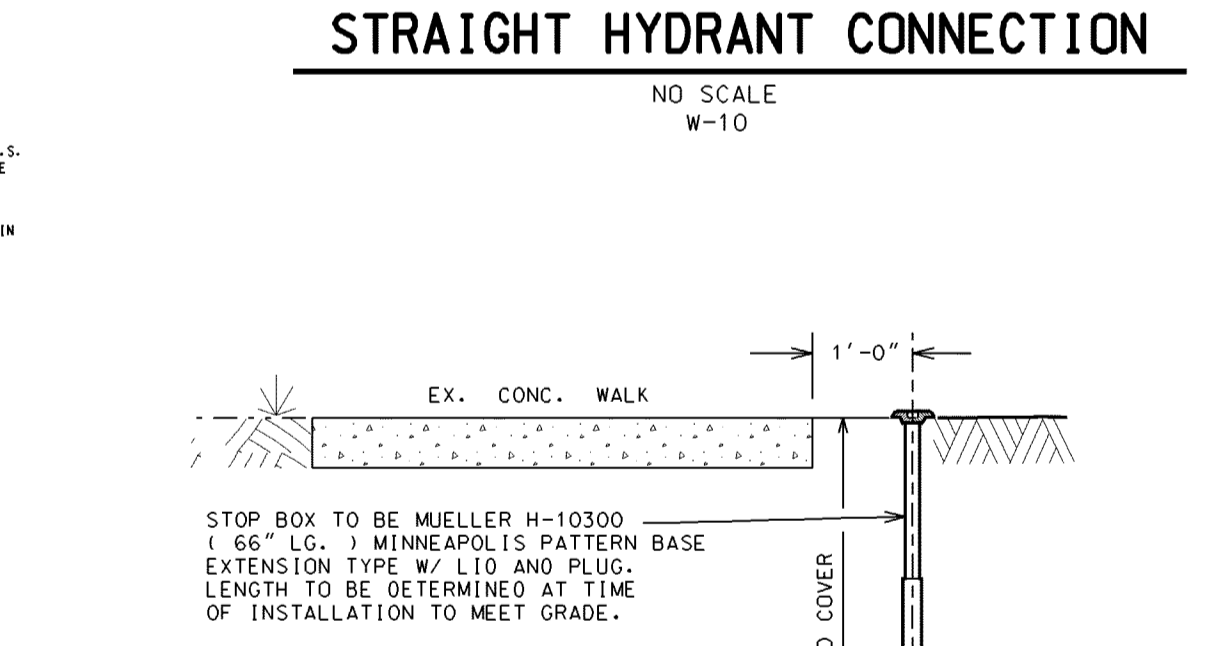
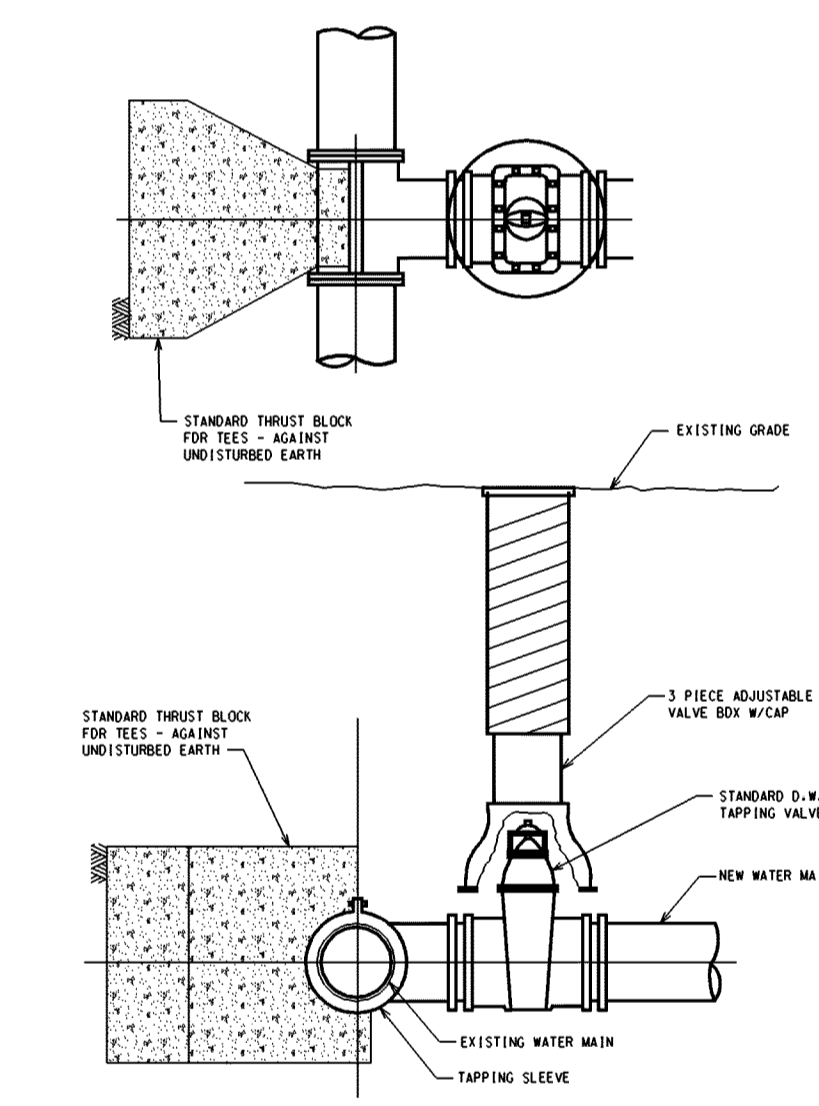
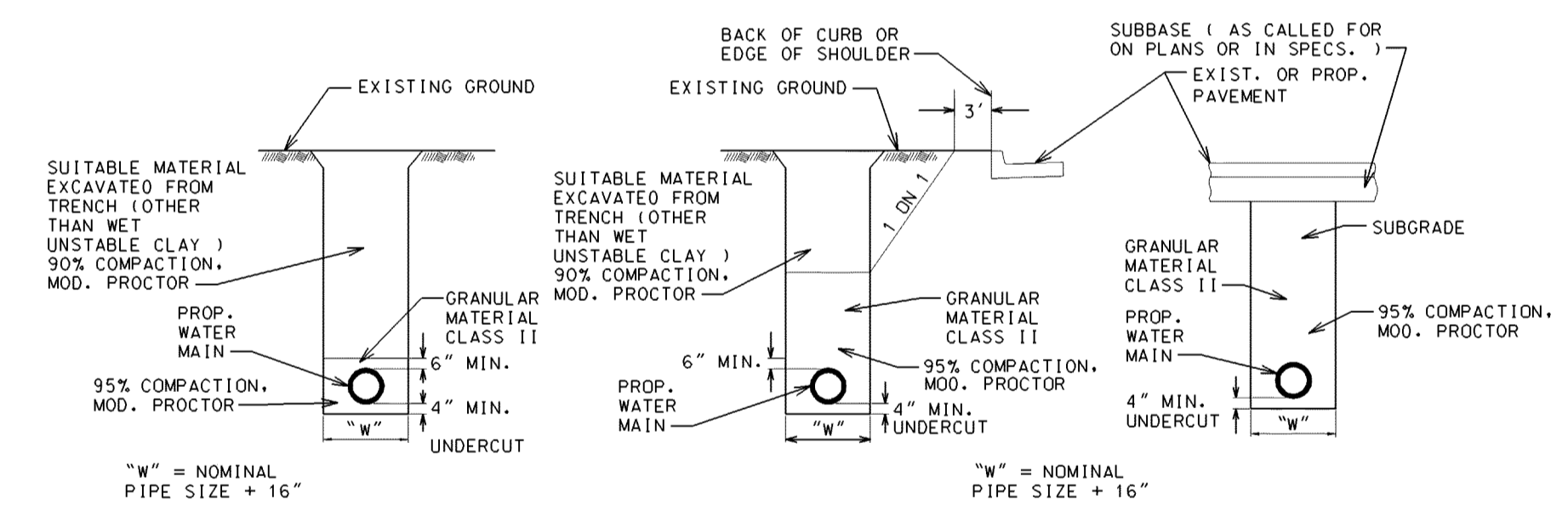
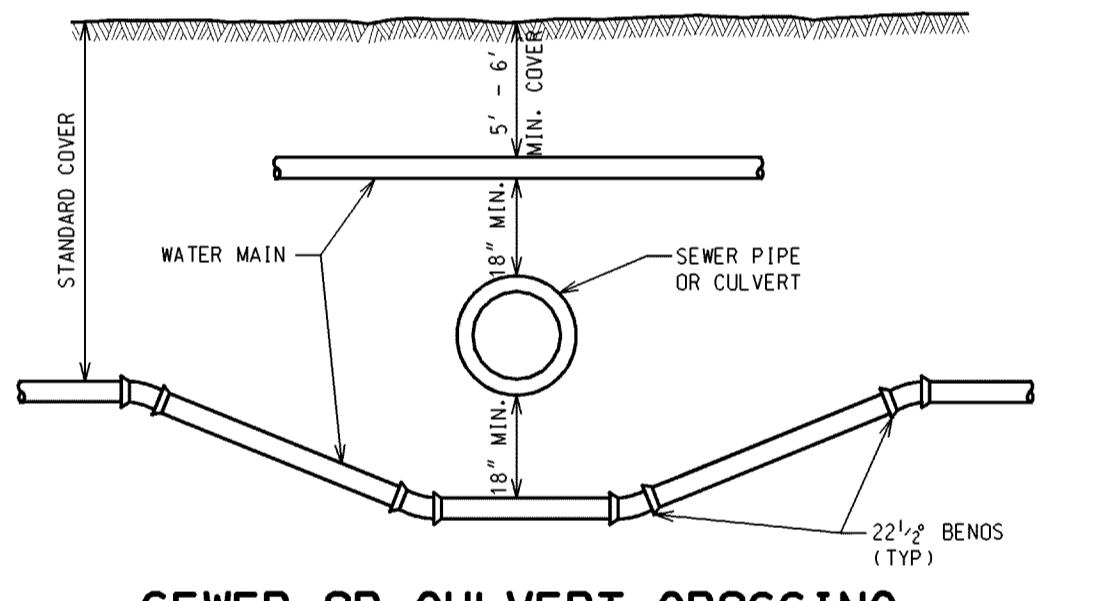
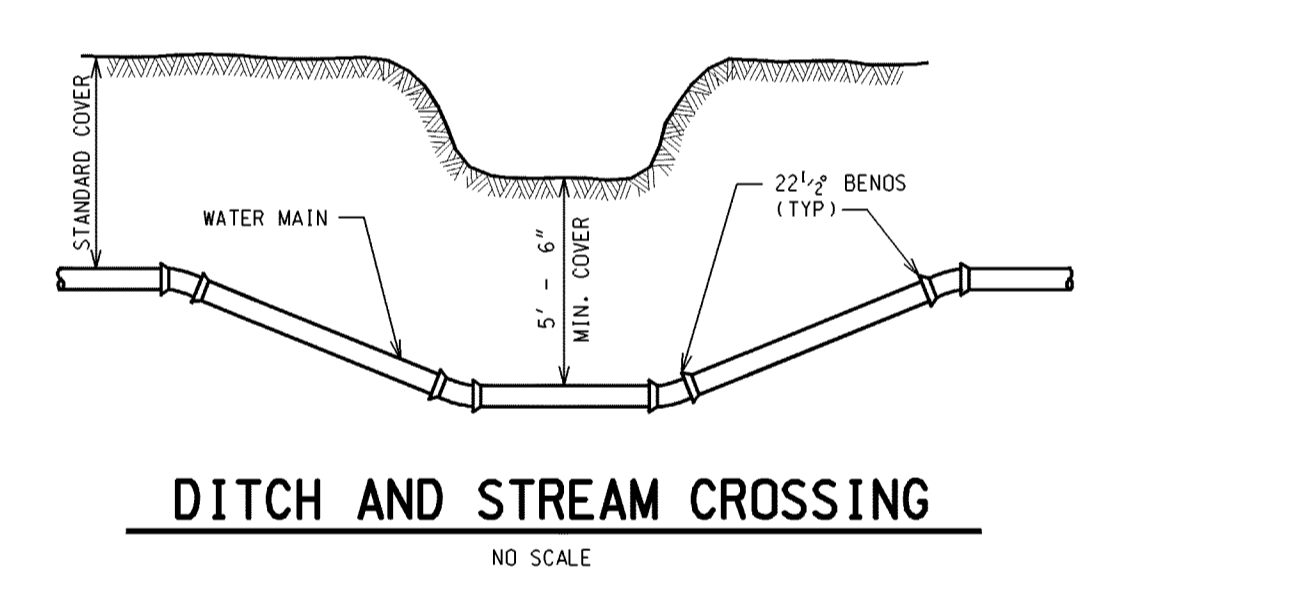
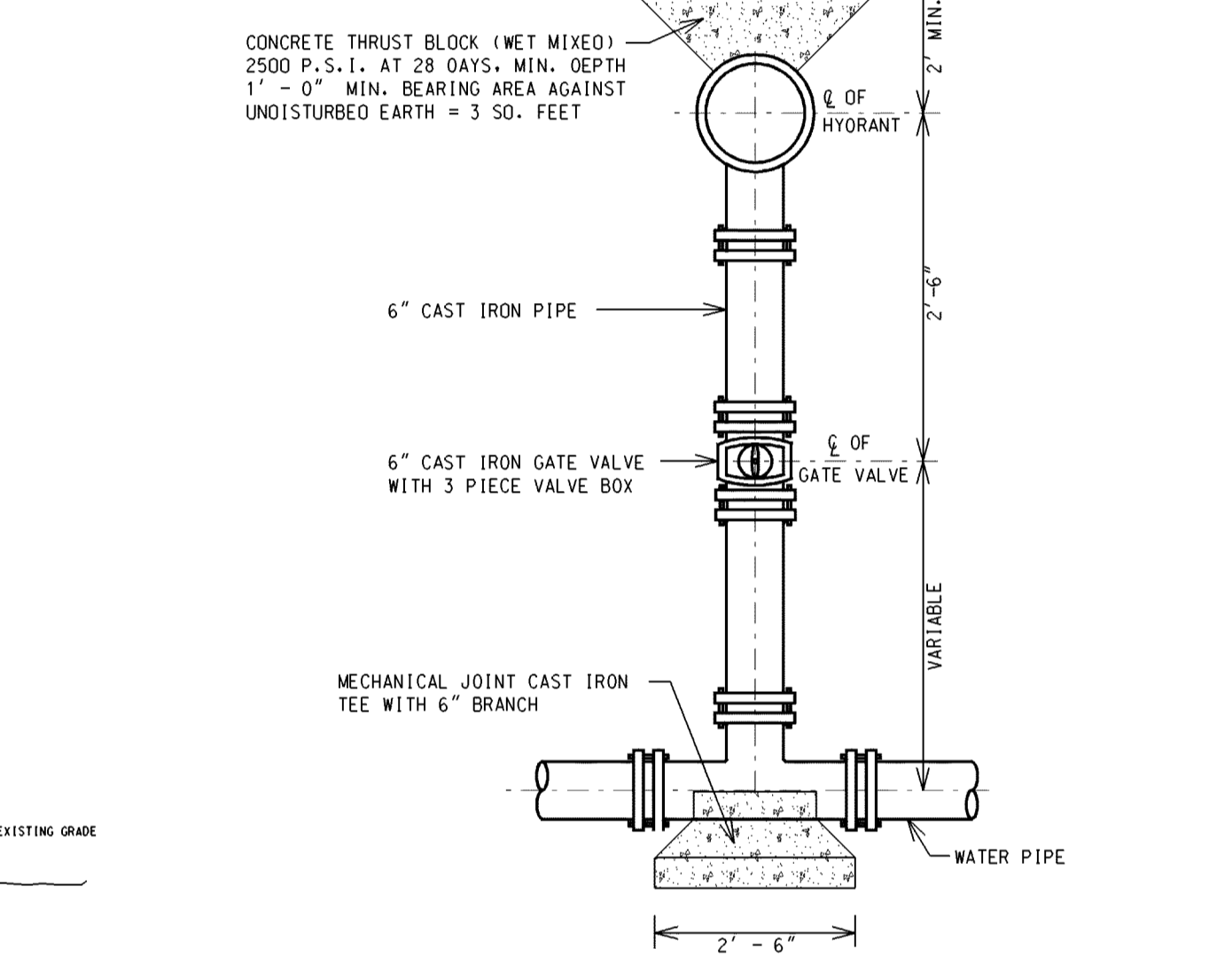
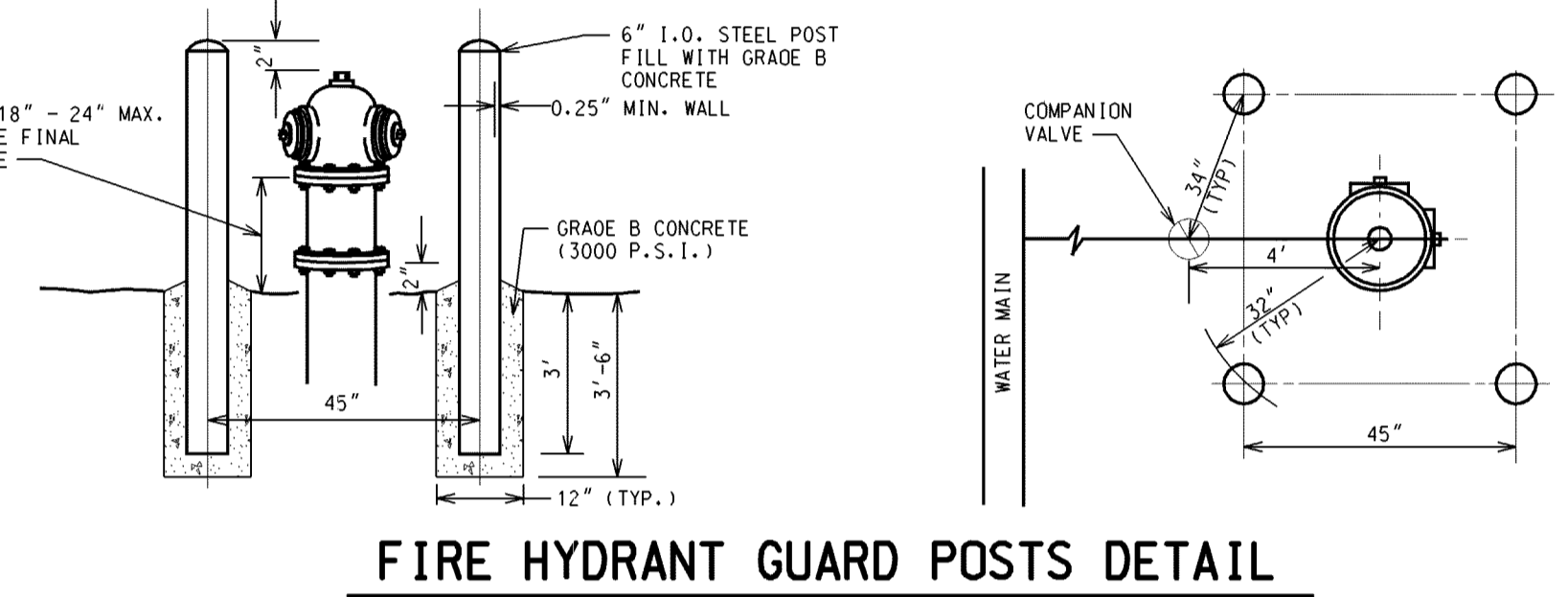
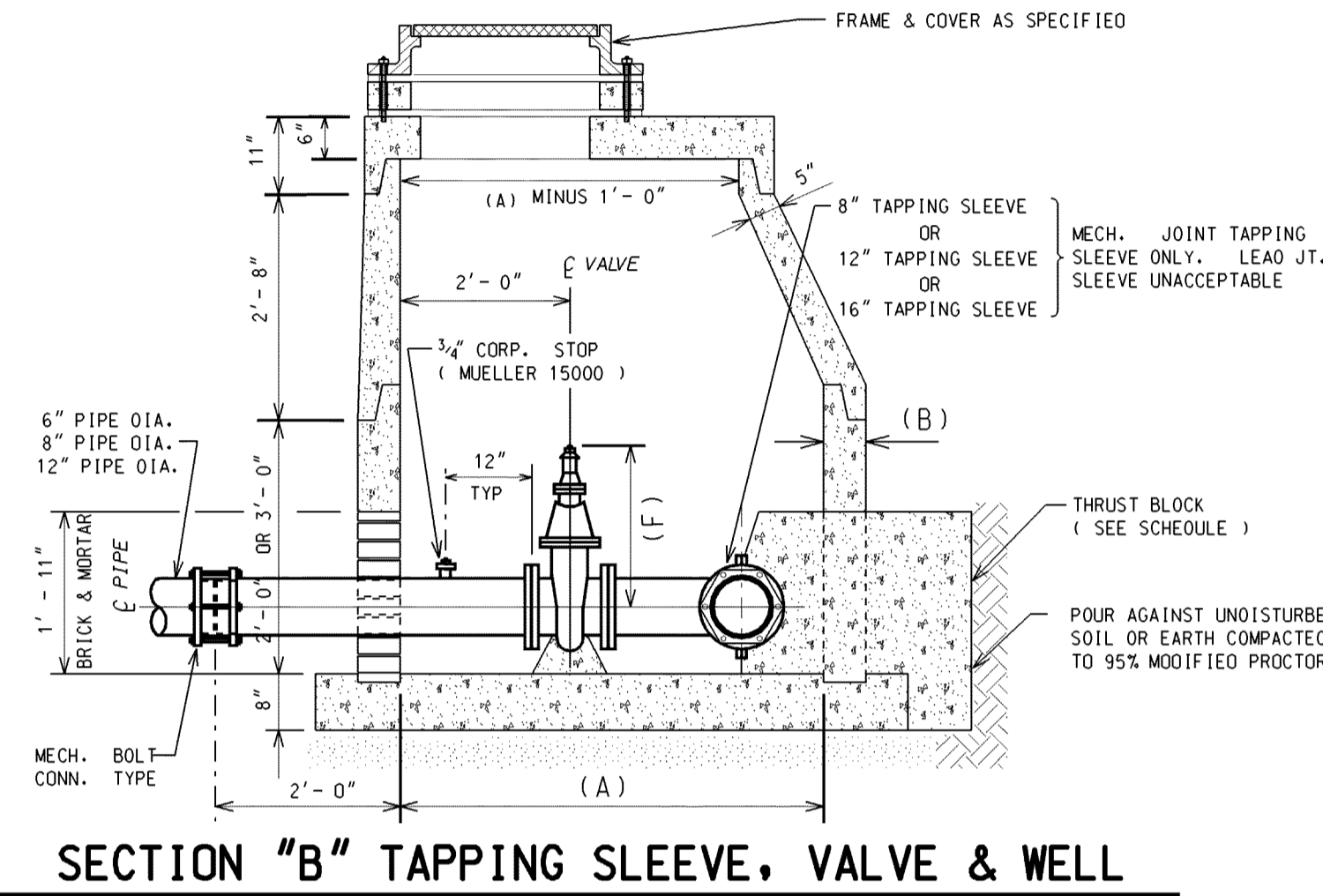
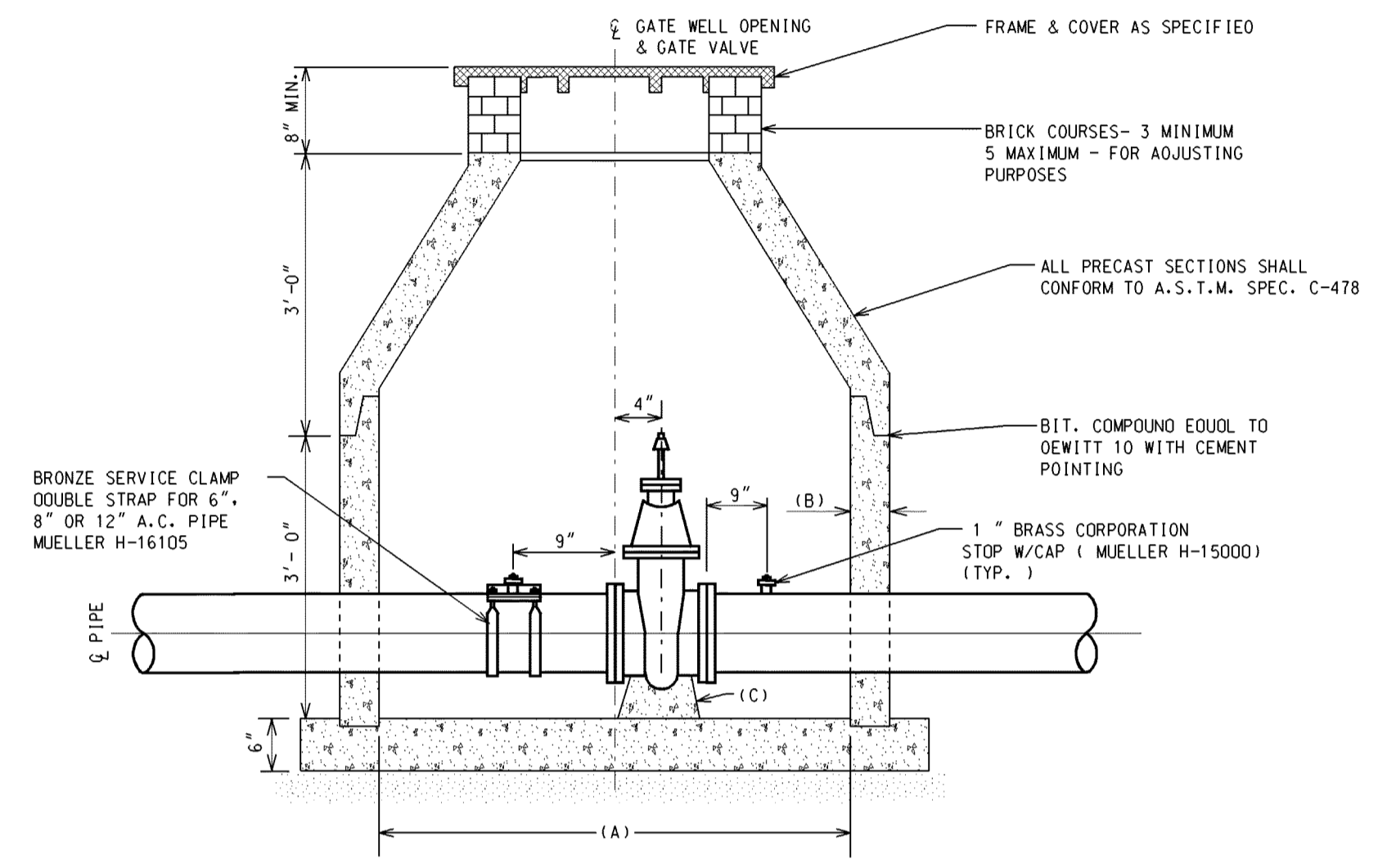

**City of Birmingham**  
A Vibrant Community

151 MARTIN STREET BIRMINGHAM, MICHIGAN 48102

**WATER MAIN STANDARD DETAILS**

DATE: \_\_\_\_\_ ADDITION AND/OR REVISION: \_\_\_\_\_ DRAWN: \_\_\_\_\_ PROJECT NO.: \_\_\_\_\_ SHEET NO.: \_\_\_\_\_  
DESIGNED: \_\_\_\_\_ DATE: APRIL 2005 WM-1  
APPROVED: \_\_\_\_\_ SCALE: \_\_\_\_\_

BROWN STREET PAVING					
PROJECT CONTRACT #5-23 (P)					
NO.	ITEM DESCRIPTION	Qty	Units		
				UNIT BID COST	UNIT COST X QTY
<b>PAVING PAY ITEMS</b>					
30	Removing Concrete Sidewalk & Ramp (sawcutting included)	835	SY	\$ 51.75	\$ 43,211.25
35	Concrete Sidewalk, 4", Scoring Treatment	6445	SF	\$ 12.25	\$ 78,951.25
36	Concrete Sidewalk, 6", Scoring Treatment (Includes Ramps)	855	SF	\$ 14.25	\$ 12,183.75
37	Concrete Sidewalk, 8", Scoring Treatment	400	SF	\$ 15.25	\$ 6,100.00
38	Concrete Sidewalk, 4", Exposed Aggregate, Scoring Treatment	1698	SF	\$ 25.50	\$ 43,299.00
39	Concrete Sidewalk, 6", Exposed Aggregate, Scoring Treatment	217	SF	\$ 30.50	\$ 6,618.50
40	Handicap Ramp Truncated Domes (per ramp)	192	SF	\$ 107.00	\$ 20,544.00
60	Maintenance Aggregate	1	LS	\$ 19,500.00	\$ 19,500.00
33	Concrete Pavement, Non-reinforced, 9", incl. integral Detail F2 Curb & Gutter	1585	LF	\$ 156.00	\$247,260.00
41	Concrete Curb & Gutter, 18", MDOT Type F2, Modified	231	LF	\$ 51.00	\$ 11,781.00
31	Removing Pavement Full Depth (Curb & Gutter included)	1970	SY	\$ 51.75	\$101,947.50
				Paving Subtotal	\$591,396.25
				Per/LFT	\$ 732.04
<b>LANDSCAPE ITEMS</b>					
73	Structural Soil Mix (30" depth)	5,073	CFT	\$ 3.00	\$ 15,219.00
74	Organic Plant Soil Mix - Plant Beds (24" depth)	3,713	CFT	\$ 3.50	\$ 12,995.50
75	Native MI Stone (3"-6") choked in w/ decorative aggregate	1	LS	\$ 2,000.00	\$ 2,000.00
76	Shredded Hardwood Mulch (3" depth)	24	CY	\$ 80.00	\$ 1,920.00
77	TILIA AMERICANA 'MCKSENTRY' (3-3.5" CAL.)	3	EA	\$ 1,000.00	\$ 3,000.00
78	ULMUS AMERICANA 'PRINCETON' (3-3.5" CAL.)	4	EA	\$ 900.00	\$ 3,600.00
79	ZELKOVA SERRATA 'JFS-KW1' (3-3.5" CAL.)	3	EA	\$ 900.00	\$ 2,700.00
80	MALUS X 'JEFSPIRE' (2" CAL.)	3	EA	\$ 700.00	\$ 2,100.00
81	HYDRANGEA PANICULATA 'JANE' (#5)	31	EA	\$ 95.00	\$ 2,945.00
82	ILEX GLABRA 'SHAMROCK' (#3)	6	EA	\$ 95.00	\$ 570.00
83	JUNIPERUS SQUAMATA 'BLUE STAR' (#3)	18	EA	\$ 70.00	\$ 1,260.00
84	PINUS MUGO 'HONEYCOMB' (#3)	21	EA	\$ 75.00	\$ 1,575.00
85	GERANIUM X 'ROZANNE' (#1)	24	EA	\$ 20.00	\$ 480.00
86	PACHYSANDRA TERMINALIS 'GREEN CARPET' (24/FLAT)	892	EA	\$ 2.75	\$ 2,453.00
87	PEROVSKIA 'LITTLE SPIRE' (#2)	41	EA	\$ 20.00	\$ 820.00
88	RUDBECKIA HIRTA (#1)	35	EA	\$ 20.00	\$ 700.00
89	PENNISETUM ALOPECUROIDES 'LITTLE BUNNY' (#2)	91	EA	\$ 30.00	\$ 2,730.00
90	SELSERIA AUTUMNALIS (#1)	48	EA	\$ 20.00	\$ 960.00
				Landscape Subtotal	\$ 58,027.50
				Per/LFT	\$ 71.83
<b>IRRIGATION ITEMS</b>					
61	Meter Pit	1	EA	\$ 8,700.00	\$ 8,700.00
62	Sprinkler Assembly	76	EA	\$ 100.00	\$ 7,600.00
63	Valve Assembly	4	EA	\$ 800.00	\$ 3,200.00
64	1-1/2 inch PVC Mainline	202	LF	\$ 18.25	\$ 3,686.50
65	1-1/2 inch Polyethylene lateral line	5	LF	\$ 9.00	\$ 45.00
66	1 inch Polyethylene lateral line	936	LF	\$ 1.20	\$ 1,123.20
67	Communication Cable - two wire	202	LF	\$ 2.00	\$ 404.00
68	Irrigation Controller	1	EA	\$ 6,000.00	\$ 6,000.00
69	Rain Sensor	1	EA	\$ 300.00	\$ 300.00
70	Two Wire Decoders	4	EA	\$ 625.00	\$ 2,500.00
71	4" PVC Sleeve	145	LF	\$ 25.00	\$ 3,625.00
72	2" PVC Sleeve	278	LF	\$ 11.00	\$ 3,058.00
				Irrigation Subtotal	\$ 40,241.70
				Per/LFT	\$ 49.81
				TOTAL	\$689,665.45
				TOTAL PER/LFT	\$ 853.68

<b>BROWN STREET PAVING</b>						
<b>PROJECT CONTRACT #5-23 (P)</b>						
<b>Breakdown</b>						
<b>SAD COST</b>						
<b>Street Address</b>	<b>Sidwell</b>	<b>Frontage Length (LFT)</b>	<b>Assessable Frontage Length (LFT) (75%)</b>	<b>Bid Unit Cost for Assessment</b>	<b>Estimate SAD Assessment for Street with Frontage</b>	<b>City Cost</b>
325 S Old Woodward	08-19-36-208-015	141.01	105.76	\$ 853.68	\$ 90,283.45	\$ 30,094.48
355 S Old Woodward	08-19-36-208-016	48.00	36.00	\$ 853.68	\$ 30,732.61	\$ 10,244.20
34745 Woodward	08-19-36-208-004	189.00	141.75	\$ 853.68	\$ 121,009.66	\$ 40,336.55
255 S Old Woodward	08-19-36-206-021	82.00	61.50	\$ 853.68	\$ 52,501.55	\$ 17,500.52
34901 Woodward	08-19-36-207-010	208.60	156.45	\$ 853.68	\$ 133,558.81	\$ 44,519.60
*Chester Parking Structure	08-19-36-206-024	119.26	119.26	\$ 853.68		\$ 101,810.32
*Alley	08-19-36-206-023	20.00	20.00	\$ 853.68		\$ 17,073.67
<b>Total</b>		<b>807.87</b>	<b>640.72</b>		<b>\$ 428,086.09</b>	<b>\$261,579.36</b>
<i>* - City Property Does not get assesment</i>						



## **MEMORANDUM**

Clerk's Office

**DATE:** May 3, 2023

**TO:** Melissa Coatta, City Engineer

**FROM:** Christina Woods, Deputy Clerk

**SUBJECT:** Clerk's Confirmation of Public Hearing Notice: Brown Street Sidewalk and Streetscape

---

The public hearing notice process has been completed for Brown Street Sidewalk and Streetscape. Please see attachments for further confirmation.

Mailing Date: 4/25/2023

Test Mail Return Date:

Publishing Dates in the Oakland Press: April 28, 2023 and May 5, 2023

Posted on [www.bhamgov.org/publicnotices](http://www.bhamgov.org/publicnotices): 4/25/2023

Attachments:

1. Public Hearing Notice
2. Addresses
3. Mailing Letter
4. Mail Machine Counter Report
5. Proof of publishing for 4/28/2023. Second publishing date will be 5/5/2023

<b>NOTICE OF PUBLIC HEARINGS</b>	
<b>BIRMINGHAM CITY COMMISSION</b>	
<b>PUBLIC HEARING OF NECESSITY</b>	
<b>PUBLIC HEARING OF CONFIRMATION</b>	
Meeting Date, Time, Location:	HEARING OF NECESSITY FOR SPECIAL ASSESSMENT DISTRICT Monday, May 8, 2023, 7:30 PM Municipal Building, 151 Martin, Birmingham, MI 48009
Meeting Date, Time, Location:	HEARING FOR CONFIRMATION OF THE ROLL Monday, May 22, 2023, 7:30 PM Municipal Building, 151 Martin, Birmingham, MI 48009
Project Location:	<b>Brown Street Sidewalk and Streetscape SAD</b> 
Nature of Improvement:	For the purpose of a Special Assessment District for sidewalk and streetscape improvements adjacent to all properties within the project area on Brown Street, from S. Old Woodward Ave. to Woodward Ave
City Staff Contact:	Melissa Coatta, City Engineer <a href="mailto:mcoatta@bhamgov.org">mcoatta@bhamgov.org</a> , (248)530-1839
Notice Requirements:	Mail to affected property owners Publish April 28 2023 and May 5 2023
Approved minutes may be reviewed at:	City Clerk's Office or <a href="http://www.bhamgov.org/commissionagendas">www.bhamgov.org/commissionagendas</a>
Should you have any statement regarding the above, you are invited to attend the meeting in person or virtually through ZOOM: <b><a href="https://zoom.us/j/655079760">https://zoom.us/j/655079760</a> Meeting ID: 655 079 760</b>	
You or your agent may appear at the hearings to express your views; however, if you fail to protest either in person or by letter received on or before the date of the hearing, you cannot appeal the amount of the special assessment to the Michigan Tax Tribunal. Mail any correspondence to: City Clerk, P.O. Box 3001, Birmingham, MI 48012.	
The property owner may file a written appeal of the special assessment with the State Tax Tribunal within 30 days after the confirmation of the special assessment roll if that special assessment was protested at the hearing held for the purpose of confirming the roll.	
All special assessments, including installment payments, shall, from the date of the confirmation thereof, constitute a lien on the respective lots or parcels assessed, and until paid shall be charged against the respective owners of the lots or parcels assessed.	
Persons with disabilities needing accommodations for effective participation in this meeting should contact the City Clerk's Office at 248.530.1880 (voice) or 248.644.5115 (TDD) at least one day in advance to request mobility, visual, hearing or other assistance.	



Number	Parcel	Name 1	Name 2	Address	City	State	Zip
1	1936206021	PARK PLAZA OF BIRMINGHAM LLC		210 S OLD WOODWARD AVE STE 230	BIRMINGHAM	MI	48009
2	1936206023	CITY OF BIRMINGHAM		151 MARTIN ST	BIRMINGHAM	MI	48009
3	1936206024	CITY OF BIRMINGHAM		151 MARTIN ST	BIRMINGHAM	MI	48009
4	1936207010	WOODWARD BROWN ASSOCIATES LLC		32820 WOODWARD AVE STE 200	ROYAL OAK	MI	48073
5	1936207010	LJ PROPERTIES MI LLC		34915 WOODWARD AVE	BIRMINGHAM	MI	48009
6	1936207010	DAVID J CONNELL REVOC TRUST	DAVID J CONNELL TRUSTEE	34901 WOODWARD AVE STE 500	BIRMINGHAM	MI	48009
7	1936207010	WOODWARD BROWN ASSOCIATES LLC		32820 WOODWARD AVE STE 200	ROYAL OAK	MI	48073
8	1936208004	BMW KAR WASH LLC		28845 TELEGRAPH RD	SOUTHFIELD	MI	48034
9	1936208015	325 S OLD WOODWARD LLC		330 HAMILTON ROW STE 300	BIRMINGHAM	MI	48009
10	1936208016	FULLER CENTRAL PARK PRPRTS		112 PEABODY ST	BIRMINGHAM	MI	48009
11	1936206021	Occupant		255 S OLD WOODWARD AVE	BIRMINGHAM	MI	48009
12	1936207010	Occupant		34901 WOODWARD AVE	BIRMINGHAM	MI	48009
13	1936207010	Occupant		34901 WOODWARD AVE # 200	BIRMINGHAM	MI	48009
14	1936207010	Occupant		34901 WOODWARD AVE # 3	BIRMINGHAM	MI	48009
15	1936208004	Occupant		34745 WOODWARD AVE	BIRMINGHAM	MI	48009
16	1936208015	Occupant		325 S OLD WOODWARD AVE	BIRMINGHAM	MI	48009
17	1936208016	Occupant		355 S OLD WOODWARD AVE	BIRMINGHAM	MI	48009
18		City of Birmingham	City Clerk's Office	151 Martin	Birmingham	MI	48009





Tuesday, April 25, 2023

TO:

City of Birmingham  
City Clerk's Office  
151 Martin  
Birmingham, MI 48009

RE: Brown Street Paving Project  
Sidewalk and Street Scape Special Assessment District

As part of the improved pedestrian crossing by the Michigan Department of Transportation (MDOT) at the Woodward Avenue and Brown Street/Forest Avenue intersection, the City will reconstruct the pavement along Brown Street between S. Old Woodward Avenue to Woodward Avenue. The proposed work will include new concrete pavement and sidewalk and streetscape features from the new back of curb to the limits of the road right-of-way.

The streetscape improvements will consist of an enhanced version of the downtown standard sawcut concrete sidewalk with an exposed aggregate sidewalk between the main pedestrian path and the street curb. Elements of the new streetscape design to be constructed as part of this project include:

- All new concrete and exposed aggregate sidewalks from the building face to the back of the curbs.
- Enlarged, raised planter beds, framed by a 6-inch high exposed aggregate curb, with irrigation, and professionally designed landscaping.

Construction on this project is anticipated to start in the summer of 2023 and be completed by the end of August 2023.

With this letter you are receiving a notification for a public hearing, with the Public Hearing of Necessity being scheduled to occur on **Monday, May 8, 2023** at the regularly scheduled City Commission meeting at 7:30 p.m. This is to consider a Special Assessment District (SAD) for sidewalk and streetscape improvements as part of the Brown Street Paving Project.

Consistent with previous projects of this nature, it has been the City's policy to assess 75% of the streetscape construction to the properties that share frontage with the improvements. The cost per property will be assessed as an average cost per linear foot of frontage for the improvements. The properties with multiple owners will share the cost of the frontage, and the amount will be based on the square footage of the building area owned. The City will bill one-tenth of the assessment, as would be done on other special assessment districts, plus interest, on an annual basis, to make the cost more manageable for the property owners.

If you have any questions or concerns, please contact the Engineering Office at (248) 530-1850. You have the opportunity to speak directly to the City Commission at the Public Hearing of Necessity that will be held on May 8, 2023.

Sincerely,

A handwritten signature in blue ink that reads "Melissa A. Coatta".

Melissa A. Coatta, P.E.  
City Engineer

# Mail Machine Counter Report

Funds Report	Available:	\$103.58	PBP Account Number:	35884980
	Used:	\$19,896.42	Indicia Number:	0001404691
	Total Pieces:	30293	Meter Number:	1404691
	Control Sum:	\$20,000.00	Meter Name:	
	Resettable Piece Count:	18	Printed:	APR 25 2023 2:41 PM
	Piece Count Value:	\$10.80		

MLB

# Mexico has 'unprecedented appetite for baseball' after WBC

**By Carlos Rodríguez**  
The Associated Press

MEXICO CITY — Major League Baseball is heading south of the border again to play a regular season series. After previous stops in Monterrey, Mexico City will be the host this time, and the timing seems perfect.



ASSOCIATED PRESS FILE PHOTO

A Mexico fan cheers during the fourth inning of a World Baseball Classic game between Japan and Mexico, March 20, in Miami.

The San Diego Padres will play against the San Francisco Giants next weekend at the Alfredo Harp Helu (AHH) Stadium in the country's capital, where fans are eager to watch more baseball after Mexico's deep run at the World Baseball Classic. Bolstered by Cuban defector Randy Arozarena and Mexican-born big leaguers like Julio Urias and Jose Uruquidy, Mexico made it to the semifinals before losing to eventual champion Japan. The journey included a stunning victory over the United States in Phoenix with tens of thousands of Team Mexico fans on hand.

"Those two weeks of the World Baseball Classic are probably the ones where everybody was talking about baseball across the country more than ever before," said

Horacio De La Vega, the president of the Mexican Baseball League.

"Clearly that outcome of the tournament is giving us a boost, we have packed stadiums in pre-season games, while in the past we used to have them at 10-20% capacity," added De La Vega in an interview with The Associated Press. "We have an unprecedented appetite for baseball."

That interest in baseball was evident in the pre-season but also last weekend when Liga Mexicana de Beisbol played the first series of the

regular season.

In the capital, fans flooded the gates of AHH Stadium for a three-day series featuring the local Diablos Rojos del México playing against the Tigres de Quintana Roo.

"I've been a Diablos Rojos fan my whole life, so this is not a new passion for me, but I've known a lot of people that have been asking me recently about the sport and that they want to come and see it for themselves," said Ramiro Aguirre, a 35-year-old accountant who was at the stadium for the opening series.

rele, and members of the Mercury organization gave the WNBA star a standing ovation as she appeared from behind a banner and climbed onto the riser.

## Griner

FROM PAGE 1

Griner kept a low profile following her return to the U.S. while adjusting to life back home, outside of appearances at the Super Bowl, the PGA Tour's Phoenix Open and an MLK Day event in Phoenix.

She returned to the spotlight at a news conference on Thursday, an event attended by roughly 200 people inside the lobby of the Footprint Center, home of the Phoenix Mercury and the NBA's Phoenix Suns.

Arizona Gov. Katie Hobbs, Griner's wife, Che-

Young had a spectacular career at Alabama and the Panthers are hoping he can deliver the franchise's first Lombardi Trophy. He played in a pro-style offense under offensive coordinator Bill O'Brien, the former Texans head coach who has returned to the NFL to run New England's offense.

The Lions traded down to select Alabama running back Jahmyr Gibbs with the No. 12 pick overall, giving up their first pick and a third-rounder to Arizona for a first-round selection and the 34th spot overall.

## Draft

FROM PAGE 1

able to physically withstand all the hits in the NFL.

Kyle Murray, the No. 1 overall pick in 2019, is the only other QB since 2003 to be selected in the first round after weighing in at 207 pounds or less at the combine.

"I'm confident in my abilities," Young said Wednesday. "I don't know how to play the game another way. I've been this size relative to the people around me my entire life. I focus on what I control, and I can't grow. That doesn't fall into that category. I can't get any taller. I focus on myself. I'm confident in myself with what I've been able to do and I'm excited for the work it's going to take."

## Opener

FROM PAGE 1

by Ava Gushen in the bottom of the inning.

"We're starting to get into it. Offensively and defensively, we have a game plan, and everyone knows what those are, and when they're supposed to be doing it," Smith said. "Right now, we're just making sure our pitchers are hitting their spots, and if we get out-hit, we've gotta out-hit them back. We got ourselves in a little lull, where our bats got a little cold, and then it was too late."

The opener went the opposite way, with Ratick reaching on a fielder's choice and coming home on a wild pitch to make it 1-0 Clarkston in the second. Cady made it 2-0 with a third-inning sacrifice fly, then — after the Raiders tied it 2-2 with RBI singles and 2-2 with RBI singles by Carrillo and Collins in the fourth — put the Wolves back ahead with an RBI triple in the fifth. Gracie Cantley's RBI double made it 4-2 after six, then Wolves starting pitcher, Nakenna

Knouf, helped her own cause with a leadoff triple in the seventh, scoring an insurance run on an RBI double by Cady, who then scored on Toltmie's RBI single.

The split could eventually be big for what should be a very tight OAA Red race, where every win is critical, and sweeps are a bonus. "Everyone is in this league for a reason, and they're going to be competitive, and I think everyone's going to approach it with a sense of scrappiness, and they're going to take runs where they can get runs, and we're going to have to have that same mentality," Smith said. "We're going to stick to our game plan and if there are some hits that don't go our way, we're going to have to make sure that we're focusing on being baserunners, not heroes."

Clarkston (2-1, 1-1 OAA Red) returns to action Thursday at rival Lake Orion (8-0, 3-0 OAA Red), while North Farmington (3-3, 1-1 OAA Red) visits Rochester Adams (6-3-2, 2-0 OAA Red) on Thursday.

NHL

# Playoffs: Kraken, Bruins, Hurricanes & Stars can advance

**By Stephen Whyno**  
The Associated Press

The defending champions are on the ropes, and the best team in the NHL has another chance to move on to the second round of the playoffs.

All four first-round series resuming Friday night feature a Game 6 with potential elimination. The most surprising team on the brink is Colorado, down 3-2 to the Kraken with the series going back to Seattle.

There are a pair of second-chances in the East, with top-seeded Boston trying to put away Florida and Carolina looking to advance past the New York Islanders. Out West, Dallas is on the verge of knocking off Minnesota and moving on.

All eyes now are on the Avalanche, who are one loss away from being the first reigning Stanley

Cup champion to lose to a team making its first playoff appearance in franchise history.

"With the culture we have here, belief is the biggest thing and that's instilled from the top down, so that's never going to go away," veteran forward Andrew Cogliano said Thursday. "But I think we're at a point now where action is much louder than words."

It's time for action from the Bruins, too, after they missed their first chance to move past the Panthers, with an overtime loss Wednesday punctuated by uncharacteristic mistakes.

As captain Patrice Bergeron said afterward, he and his teammates can't give an opportunity to opponent "freebies" as they did in Game 5 at home.

Game 6 is on the road at Florida, and the Bru-

ins still have the series lead looking to be the 10th Presidents' Trophy winners in the past 11 years to win at least one series.

"I'm sure we're going to come back with a real good, determined effort," Boston coach Jim Montgomery said. "I have a lot of confidence in our team."

Confidence isn't lacking for the Avalanche, either, especially after their Cup run a year ago. They'll also get a boost with the return of 2022 playoff MVP Cale Makar from a one-game suspension.

But much like Boston, the pressure is on Colorado.

"They're playing loose, they're confident," coach Jared Bednar said of the Kraken. "Obviously the guys in their room are like, 'Yeah, we want to win,' but expectations are on our team."

(Texas) and Mordecai (SMU) are transfers.

## Harbaugh

FROM PAGE 1

not gonna have a letdown as the months go on, but this is the best version of football I've seen since I've been here the last eight years."

The Wolverines bring back 84% of their offensive production. Quarterback J.J. McCarthy and running backs Blake Corum and Donovan Edwards will work behind the nation's best offensive line. The defense is loaded, especially in the front seven, and linebackers Ernest Hausmann (Nebraska) and Josaiah Stewart (Coastal Carolina) are transfers who showed this spring they're capable of making big impacts.

**Quarterback questions**  
As many as six quar-

terback competitions will come into the fall. The battles: Kyle McCord vs. Devin Brown at Ohio State, Brenden Sorsby vs. Tayven Jackson at Indiana, Payton Thorne vs. Noah Kim and Katin Houser at Michigan State, Jeff Sims vs. Casey Thompson at Nebraska, Brendan Sullivan vs. Ryan Hilsinki at Northwestern and Gavin Wimsatt vs. Evan Simon at Rutgers.

Eight teams appear set at quarterback: McCarthy at Michigan, Cade McNamara at Iowa, Luke Altmyer at Illinois, Taulia Tagovailoa at Maryland, Athan Kaliakmanis at Minnesota, Drew Allar at Penn State, Hudson Card at Purdue and Tanner Mordecai at Wisconsin.

Jackson (Tennessee), Sims (Georgia Tech), McNamara (Michigan), Altmyer (Mississippi), Cald-

## Inheriting a winner

Purdue's Walters, the former Illinois defensive coordinator, is the rare head coach who takes over a winning team.

The Boilermakers won the West Division last season, were 36-34 and went to four bowls in six seasons under Jeff Brohm, who left for Louisville.

"Yeah, it's not a rebuild, right?" Walters said. "I'm trying to elevate and really dive into it and understand the tradition and the standard here. It will be my job to raise that standard and continue to race and win championships."

Among Purdue's starters in the Big Ten championship game, seven on offense and four on defense were on the spring roster.

## On the air

TODAY

**AUTO RACING**  
Formula 1, Qualifying, Baku City Circuit, Baku, Azerbaijan: 8:55 a.m., ESPN  
**NASCAR Xfinity Series, Qualifying, Dover Motor Speedway, Dover, Del.: 3 p.m., FS1**  
**NHRA, Qualifying, zMAX Dragway, Concord, N.C.: 7 p.m., FS1**

**Formula 1, Grand Prix Sprint Shootout, Baku City Circuit, Baku, Azerbaijan: 4:25 a.m., SEC**  
**Alabama at LSU: 7 p.m., SEC**  
**Minnesota at Nebraska: 8 p.m., BTN**  
**UCLA at Stanford: 10 p.m., ESPN**  
**COLLEGE LACROSSE (men)**  
Boston U. at Army: 6:15 p.m., CBSN  
**COLLEGE LACROSSE (women)**  
Loyola (Md.) at Navy: 6 p.m., CBSN  
**COLLEGE SOFTBALL**  
Florida A&M at Jackson St.: 4:30 p.m., ESPN

**PGA Tour Champions, The Inverrary Invitational, First Round, The Woodlands Country Club - Tournament Course, The Woodlands, Texas: Noon, GOLFLIVE**  
**PGA Tour, The Mexican Open, Second Round, Vidanta Vallarta, Jalisco, Mexico: 3:30 p.m., GOLFLIVE**  
**PGA Tour, The JM Eagle LA Championship, Second Round, Wilshire Country Club, Los Angeles: 6:30 p.m., GOLFLIVE**  
**DP World Tour, The Korea Championship, Third Round, Jack Nicklaus Golf Club Korea, Incheon, South Korea: Midnight, GOLFLIVE**  
**NHRA, America's Day at the Races: 4 p.m., FS2**  
**MLB BASEBALL**  
Kansas City at Minnesota: 4 p.m., MLB  
Baltimore at Detroit: 6:30 p.m., BSN  
Atlanta at NY Mets or Pittsburgh at Washington: 7 p.m., MLB

**NBA BASKETBALL**  
**Western Conference First Round, Sacramento at Golden State, Game 6: 8:10 p.m., ESPN**

## CITY OF BERKLEY, MICHIGAN NOTICE OF PUBLIC HEARING REGARDING THE PROPOSED 2023/24 CITY OPERATING BUDGET

The City Council of the City of Berkley, Michigan will hold a public hearing during its regularly scheduled Meeting of the City Council at 7 p.m. on May 15, 2023. The property tax millage rate proposed to be levied to support the proposed operating budget of the City will be a subject of the hearing. The maximum millage rates proposed to be levied for operating purposes are as follows: net tax increment capture:

Purpose:	Rate Per \$1,000 Taxable Assessed Value	Estimated Net Tax Levy Revenues
General Operation	5.3747	\$3,915,724
General Operation - Voted	2.5552	\$1,861,584
Public Safety Operation	1.6120	\$1,174,418
Sanitation Operation	1.6120	\$1,174,418
Community Promotion	.0652	\$47,501
Public Safety Pension	2.7000	\$1,751,844
Infrastructure	1.8507	1,231,062
Dist. Millage	0.000	0.00
<b>Total Proposed City Levy:</b>	<b>15.7698</b>	<b>\$11,489,046</b>
Downstream Development Authority	\$1.8184	\$37,863

Copies of the proposed operating budget will be available for public inspection on the City of Berkley website beginning on May 1, 2023, through the office of the Berkley City Clerk starting on May 1, 2023.

The City of Berkley will make reasonable arrangements to accommodate special needs upon receiving 72-hour advance notice. Contact Victoria Mitchell, City Clerk at (248) 658-3216 at Berkley City Hall for special services.

**Victoria Mitchell, City Clerk**  
City of Berkley  
Published Friday, April 28, 2023

## UP NEXT

### TIGERS

<b>Western Conference First Round, Memphis at LA Lakers, Game 6: 10:30 p.m., ESPN</b>	<b>NFL DRAFT</b> <b>2023 NFL Draft, Rounds 2-3, Kansas City, Mo.: 7 p.m., ABC/ESPN/NFL</b> <b>2023 NFL Draft, Rounds 2-3, Kansas City, Mo.: 8 p.m., ESPN2</b> <b>NHL HOCKEY</b> <b>Eastern Conference First Round, Carolina at NY Islanders, Game 6: 7 p.m., TBS</b> <b>Eastern Conference First Round, Boston at Florida, Game 6: 7:30 p.m., TNT</b> <b>Western Conference First Round, Dallas at Minnesota, Game 6: 9:30 p.m., TBS</b> <b>Western Conference First Round, Colorado at Seattle, Game 6: 10 p.m., TNT</b>	<b>Today</b> vs. Baltimore, 6:40 p.m., BSN <b>Saturday</b> vs. Baltimore, 1:10 p.m., BSN <b>Sunday</b> vs. Baltimore, 1:40 p.m., BSN
---	--	---

## NOTICE OF PUBLIC HEARINGS

### BIRMINGHAM CITY COMMISSION PUBLIC HEARING OF NECESSITY PUBLIC HEARING OF CONFIRMATION

Meeting Date, Time, Location:	HEARING OF NECESSITY FOR SPECIAL ASSESSMENT DISTRICT Monday, May 8, 2023, 7:30 PM Municipal Building, 151 Martin, Birmingham, MI 48009
Meeting Date, Time, Location:	HEARING FOR CONFIRMATION OF THE ROLL Monday, May 22, 2023, 7:30 PM Municipal Building, 151 Martin, Birmingham, MI 48009

**Project Location:** Properties within project location: 325 S. Old Woodward: 08-19-36-208-015 325 S. Old Woodward: 08-19-36-208-016 34745 Woodward Ave: 08-19-36-208-004 295 S. Old Woodward: 08-19-36-208-021 34901 Woodward Ave: 08-19-36-207-010

**Nature of Improvement:** For the purpose of a Special Assessment District for sidewalk and streetscape improvements adjacent to properties within the project area on Brown Street, from S. Old Woodward Ave. to Woodward Ave.

**City Staff Contact:** Melissa Coatts, City Engineer mcoatts@bhamgov.org, (248)593-1839

**Notice Requirements:** Mail to affected property owners Publish April 28 2023 and May 5 2023

**Approved minutes may be reviewed at:** City Clerk's Office or www.bhamgov.org/commissionergendas

Should you have any statement regarding the above, you are invited to attend the meeting in person or virtually through ZOOM: <https://zoom.us/j/655078766> Meeting ID: 655 079 760

You or your agent may appear at the hearings to express your views; however, if you fail to protest either in person or by letter received on or before the date of the hearing, you cannot appeal the amount of the special assessment to the Michigan Tax Tribunal. Mail any correspondence to: City Clerk, P.O. Box 3001, Birmingham, MI 48818

The property owner may file a written appeal of the special assessment with the State Tax Tribunal within 30 days after the confirmation of the special assessment if that special assessment was protested at the hearing held for the purpose of confirming the roll.

All special assessments, including installment payments, shall, from the date of the confirmation thereof, constitute a lien on the respective lots or parcels assessed, and unit paid shall be charged against the respective owners of the lots or parcels assessed.

Persons with disabilities needing accommodations for effective participation in this meeting should contact the City Clerk's Office at 248.530.1880 (voice) or 248.644.5115 (TDD) at least one day in advance to request mobility, visual, hearing or other assistance.



## **MEMORANDUM**

**Finance Department**

**DATE:** May 3, 2023

**TO:** Thomas M. Markus, City Manager

**FROM:** Mark Gerber, Finance Director/Treasurer

**SUBJECT:** 2023-2024 Budget Appropriations Resolution

---

### INTRODUCTION:

As required by state law and city charter, the City Commission must annually approve a budget for the following fiscal year and approve the property tax millage to be assessed on July 1<sup>st</sup>.

### BACKGROUND:

The City held a public hearing on April 29, 2023, to review the 2023-2024 recommended budget and to receive comments and revisions from the City Commission and the general public. Based on the comments received, there were no revisions made to the manager's recommended budget or to the recommended property tax millage. Below are some updates to the recommended budget, some of which were presented at the public hearing and others based on information which was received after the public hearing.

#### Sewage Disposal Fund Budget

The City has received final sewage and storm water costs from the Oakland County Water Resources Commissioner for fiscal year 2023-2024. Based on this information, sewage disposal costs increased \$116,030 and storm water increased \$61,650. As a result, adjustments to the appropriate revenue accounts will increase revenues by \$177,680.

#### Baldwin Library Fund Budget

The proposed budget that was presented did not include a contribution of \$260,000 from the library trust. This adjustment increased total revenues to \$5,591,430 and leaves the fund with a projected positive fund balance at the end of fiscal year 2023-2024.

### LEGAL REVIEW:

None needed.

### FISCAL IMPACT:

The impact of these adjustments to the recommended budget are as follows:

<b>Sewage Disposal Fund</b>	Manager Recommended Budget	Adjusted Recommended Budget
Revenues:		
Charges for Services	\$11,105,440	\$11,283,120
Expenditures:		
Sewage Disposal Fund	\$13,695,250	\$13,872,930

<b>Baldwin Library Fund</b>	Manager Recommended Budget	Adjusted Recommended Budget
Revenues:		
Other Revenue	\$0	\$260,000

**PUBLIC COMMUNICATIONS:**

The budget hearing was noticed in the newspaper and was included in the 2023 City calendar.

**SUMMARY:**

It is recommended that the City Commission approve the budget appropriations resolution adopting the City of Birmingham’s budget and establishing the total number of mills for ad valorem property taxes to be levied for the fiscal year commencing July 1, 2023 and ending June 30, 2024.

**ATTACHMENTS:**

The budget appropriations resolution with the changes noted above is attached to this report.

**SUGGESTED COMMISSION ACTION:**

Make a motion adopting the budget appropriations resolution for the City of Birmingham’s budget and establishing the total number of mills for ad valorem property taxes to be levied for the fiscal year commencing July 1, 2023 and ending June 30, 2024.

**BUDGET APPROPRIATIONS RESOLUTION**

WHEREAS, the City Manager has submitted the proposed 2023-2024 Budget, and:

WHEREAS, the City Commission has reviewed the 2023-2024 Budget, and;

WHEREAS, the City Commission has held a Public Hearing on the 2023-2024 Budget;

WHEREAS, Chapter VII, Section 14 of the Birmingham City Charter requires that the City Commission pass an annual appropriations resolution, and;

NOW THEREFORE, BE IT RESOLVED, that the City Commission does hereby adopt the following estimated revenues for the City of Birmingham for the fiscal year commencing July 1, 2023, and ending June 30, 2024:

**GENERAL FUND:**

Taxes	\$ 33,524,900
Special Assessments	656,810
Licenses & Permits	2,720,510
Federal Grants	53,000
State Grants	2,833,900
Local Contributions	151,650
Charges for Services	3,557,890
Fines and Forfeitures	1,957,340
Interest and Rent	756,500
Other Revenue	250,130
Other Financing Sources	<u>100,000</u>
Total General Fund	\$ 46,562,630

**GREENWOOD CEMETERY PERPETUAL CARE FUND:**

Charges for Services	\$ 35,000
Interest and Rent	<u>23,000</u>
Total Greenwood Cemetery Perpetual Care Fund	\$ 58,000

**MAJOR STREETS FUND:**

State Grants	\$ 1,841,950
Interest and Rent	35,180
Other Financing Sources	3,500,000
Draw from Fund Balance	<u>1,958,990</u>
Total Major Streets Fund	\$ 7,336,120



<b>LOCAL STREETS FUND:</b>	
Special Assessments	\$ 237,740
State Grants	752,340
Interest and Rent	42,000
Other Revenue	5,000
Other Financing Sources	3,500,000
Draw from Fund Balance	<u>261,130</u>
Total Local Streets Fund	\$ 4,798,210

<b>SOLID WASTE DISPOSAL FUND:</b>	
Taxes	\$ 2,343,860
State Grants	4,000
Charges for Services	100
Interest and Rent	20,000
Other Revenue	<u>300</u>
Total Solid Waste Disposal Fund	\$ 2,368,260

<b>BROWNFIELD REDEVELOPMENT AUTHORITY FUND:</b>	
Taxes	\$ 481,830
Interest and Rent	880
Other Revenue	<u>20,000</u>
Total Brownfield Redevelopment Authority Fund	\$ 502,710

<b>PRINCIPAL SHOPPING DISTRICT FUND:</b>	
Special Assessments	\$ 1,201,500
Charges for Services	25,000
Interest and Rent	5,420
Other Revenue	220,000
Draw from Fund Balance	<u>40,690</u>
Total Principal Shopping District Fund	\$ 1,492,610

<b>COMMUNITY DEVELOPMENT BLOCK GRANT FUND:</b>	
Federal Grants	\$ 36,910

<b>TRIANGLE DISTRICT CORRIDOR IMPROVEMENT AUTHORITY FUND:</b>	
Interest and Rent	\$ 220

<b>INDIGENT DEFENSE FUND:</b>	
State Grants	\$ 494,100
Local Contributions	17,600
Interest and Rent	<u>3,000</u>
Total Indigent Defense Fund	\$ 514,700

OPIOID SETTLEMENT FUND:	
Other Revenue	\$ 50,000
<hr/>	
LAW AND DRUG ENFORCEMENT FUND:	
Fines and Forfeitures	\$ 25,000
Draw from Fund Balance	29,790
	<hr/>
Total Law and Drug Enforcement Fund	\$ 54,790
BALDWIN LIBRARY FUND:	
Taxes	\$ 4,165,640
State Grants	42,000
Local Contributions	1,093,140
Charges for Services	20,650
Fines and Forfeitures	5,000
Interest and Rent	5,000
Other Revenue	260,000
Draw from Fund Balance	2,203,880
	<hr/>
Total Baldwin Library Fund	\$ 7,795,310
DEBT SERVICE FUND:	
Taxes	\$ 1,637,910
Intergovernmental	2,770
Interest and Rent	5,500
	<hr/>
Total Debt Service Fund	\$ 1,646,180
CAPITAL PROJECTS FUND:	
Interest and Rent	\$ 20,000
Other Financing Sources	600,000
Draw from Fund Balance	580,000
	<hr/>
Total Capital Projects Fund	\$ 1,200,000
PARK SYSTEM CONSTRUCTION FUND:	
Interest and Rent	\$ 25,000
Other Financing Sources	6,237,900
	<hr/>
Total Park System Construction Fund	6,262,900
AUTOMOBILE PARKING SYSTEM FUND:	
Charges for Services	\$ 8,099,860
Interest and Rent	350,000
Draw from Net Position	7,140,200
	<hr/>
Total Automobile Parking System Fund	\$ 15,590,060

SEWAGE DISPOSAL FUND:

Taxes	\$ 314,680
Special Assessments	2,000
State Grants	550
Charges for Services	11,283,120
Interest and Rent	63,190
Draw from Net Position	<u>2,209,390</u>
Total Sewage Disposal Fund	\$ 13,872,930

WATER-SUPPLY SYSTEM RECEIVING FUND:

Taxes	\$ 399,280
Federal Grants	1,305,680
State Grants	720
Charges for Services	5,717,570
Interest and Rent	150,000
Draw from Net Position	<u>2,027,000</u>
Total Water-Supply System Fund	\$ 9,600,250

LINCOLN HILLS GOLF COURSE:

Charges for Services	\$ 900,600
Interest and Rent	37,710
Other Revenue	<u>600</u>
Total Lincoln Hills Golf Course Fund	\$ 938,910

SPRINGDALE GOLF COURSE:

Charges for Services	\$ 611,700
Interest and Rent	25,870
Draw from Net Position	<u>114,750</u>
Total Springdale Golf Course Fund	\$ 752,520

COMPUTER EQUIPMENT FUND:

Interest and Rent	\$ 1,081,300
Other Revenue	-
Draw from Net Position	<u>550,080</u>
Total Computer Equipment Fund	\$ 1,631,380

AND, BE IT FURTHER RESOLVED, that the City Commission does hereby adopt on a budgetary

GENERAL FUND:

General Government	\$ 6,557,920
Judicial	1,999,280
Public Safety	19,893,160
Public Works	6,209,820

Health and Welfare	217,630
Community and Economic Development	731,720
Transfers Out	7,600,000
Contribution to Fund Balance	<u>295,760</u>
Total General Fund	\$ 46,562,630
 GREENWOOD CEMETERY PERPETUAL CARE FUND:	
Expenditures	\$ -
Contribution to Fund Balance	<u>58,000</u>
Total Greenwood Cemetery Perpetual Care Fund	\$ 58,000
 MAJOR STREETS FUND:	
Public Works	\$ 7,336,120
 LOCAL STREETS FUND:	
Public Works	\$ 4,798,210
 SOLID WASTE DISPOSAL FUND:	
Public Works	\$ 2,363,390
Contribution to Fund Balance	<u>4,870</u>
Total Solid Waste Disposal Fund	\$ 2,368,260
 BROWNFIELD REDEVELOPMENT AUTHORITY FUND:	
Community and Economic Development	\$ 501,830
Contribution to Fund Balance	<u>880</u>
Total Brownfield Redevelopment Authority Fund	\$ 502,710
 PRINCIPAL SHOPPING DISTRICT FUND:	
Community and Economic Development	\$ 1,492,610
 COMMUNITY DEVELOPMENT BLOCK GRANT FUND:	
Health and Welfare	\$ 36,910
 TRIANGLE DISTRICT CORRIDOR IMPROVEMENT AUTHORITY FUND:	
Contribution to Fund Balance	\$ 220
 INDIGENT DEFENSE FUND:	
Health and Welfare	\$ 514,700
 OPIOID SETTLEMENT FUND:	
Health and Welfare	\$ 50,000
 LAW AND DRUG ENFORCEMENT FUND:	
Public Safety	\$ 54,790

BALDWIN LIBRARY FUND:	
Recreation and Culture	\$ 7,795,310
DEBT SERVICE FUND:	
Debt Service	\$ 1,646,180
CAPITAL PROJECTS FUND:	
Capital Outlay	1,200,000
PARK SYSTEM CONSTRUCTION FUND:	
Recreation and Culture	\$ 498,000
Capital Outlay	150,000
Contribution to Fund Balance	<u>5,614,900</u>
Total Park System Construction Fund	\$ 6,262,900
AUTOMOBILE PARKING SYSTEM FUND:	
Public Works	\$ 15,590,060
SEWAGE DISPOSAL SYSTEM FUND:	
Public Works	\$ 13,872,930
WATER-SUPPLY SYSTEM RECEIVING FUND:	
Public Works	\$ 9,600,250
LINCOLN HILLS GOLF COURSE:	
Recreation and Culture	\$ 812,750
Contribution to Net Position	<u>126,160</u>
Total Lincoln Hills Golf Course	\$ 938,910
SPRINGDALE GOLF COURSE:	
Recreation and Culture	\$ 752,520
COMPUTER EQUIPMENT FUND:	
General Government	\$ 1,631,380

BE IT FURTHER RESOLVED that the budget summary above be approved as the 2023-2024 City Budget and that this resolution shall be known as the City of Birmingham 2023-2024 General Appropriations Act.

BE IT FURTHER RESOLVED that the City Commission does hereby designate \$34,326,980 to be raised by 10.7501 mills levied for General Purposes on the taxable valuation of all real and personal property subject to taxation in the City.

BE IT FURTHER RESOLVED that the City Commission does hereby designate \$4,196,470 to be raised by 1.3142 mills levied for Library Operations on the taxable valuation of all real and personal property subject to taxation in the City.

BE IT FURTHER RESOLVED that the City Commission does hereby designate \$1,640,340 to be raised by 0.5137 mills levied for Debt Service Requirements on the taxable valuation of all real and personal property subject to taxation in the City.

BE IT FURTHER RESOLVED that the City Commission does hereby designate \$2,357,840 to be raised by 0.7384 mills levied on the taxable valuation of all real and personal property subject to taxation in the City for the purpose of the collection and removal of garbage and trash of the City as authorized by MCL 123.261, et. seq.

BE IT FURTHER RESOLVED that the City Manager is hereby authorized to make budgetary transfers within the budgetary centers established through the adoption of this budget, and that all transfers between budgetary centers may be made only by further action of the City Commission pursuant to the provisions of the Michigan Uniform Accounting and Budgeting Act.

BE IT FURTHER RESOLVED that the 2023-2024 budget shall be automatically amended on July 1, 2023, to re-appropriate encumbrances outstanding and reserved at June 30, 2023.

BE IT FINALLY RESOLVED that the City Treasurer be authorized to add to all taxes paid after August 31, 2023, three-fourths of one percent (3/4 of 1%) penalty each and every month, or fraction thereof, that remains unpaid. On all taxes paid after February 14, 2024, and through February 29, 2024, there shall be added a late penalty charge equal to three percent (3%) of such tax.



## **MEMORANDUM**

Parking System

**DATE:** 5/08/23

**TO:** Thomas M. Markus, City Manager

**FROM:** Aaron Ford, Parking Systems Manager

**SUBJECT:** Monthly Parking Rate Increase

---

### **INTRODUCTION:**

After six years, the City has budgeted and planned to increase the monthly parking rate at all five City garages. The Parking Department has multiple capital improvement projects scheduled over the next five years. A rate increase at each garage starting in July of 2023 is being requested to help pay for these projects.

### **BACKGROUND:**

April of 2017 was the last time the City increased the rate for monthly parking. At the time the rates were increased from \$35 to \$50 at the Chester St. Garage and from \$50 to \$70 at the remaining four garages. Due to COVID-19, the City waived the fee for parking from March 2020 until June 2021.

Monthly parking passes are available on a first come first serve bases at each of the five City garages. Passes are available to anyone who might find them convenient. A combination of residents, employees, and employers buy monthly passes, however the majority of monthly passes are purchased by companies looking to provide parking to their colleagues. Those people who don't have monthly parking must pay the going rate based on the amount of time they are parked. All five City garages have a tiered rate schedule with a maximum rate of \$10 per day.

The Parking Department is in the middle of numerous capital improvement projects to help improve the efficiency and maintenance of the City's parking facilities. Some of these projects include the installation of new parking equipment, ongoing concrete repairs, façade assessment of the Park St. garage, ADA compliance upgrades, painting, installation of LED lights, wayfinding signage, and making each garage compatible to support future EV charging. To help offset the cost of these projects the City is proposing to increase the rate of monthly parking at the start of the next fiscal year, which is July 1, 2023.

For comparison, the City of Ann Arbor has increased their monthly parking rate by \$5 each year. Below is a table showing the current monthly rate and the new proposed monthly rate, along with the rates of some of our local communities.

	<b>Current Rate</b>	<b>Per Day Rate (21 Days)</b>	<b>Per Day Rate (30 Days)</b>
Chester Garage	\$50.00	\$2.38	\$1.67
Old Woodward	\$70.00	\$3.33	\$2.33
Park Garage	\$70.00	\$3.33	\$2.33
Peabody Garage	\$70.00	\$3.33	\$2.33
Pierce Garage	\$70.00	\$3.33	\$2.33

	<b>Proposed Rate</b>	<b>Per Day Rate (21 Days)</b>	<b>Per Day Rate (30 Days)</b>
Chester Garage	\$70.00	\$3.33	\$2.33
Old Woodward	\$90.00	\$4.29	\$3.00
Park Garage	\$90.00	\$4.29	\$3.00
Peabody Garage	\$90.00	\$4.29	\$3.00
Pierce Garage	\$100.00	\$4.76	\$3.33

Monthly Rates	
Royal Oak	\$40-50
Rochester	\$20.00
Gross Pointe	\$40.00
Detroit	\$182 Avg
Ann Arbor	\$200.00

LEGAL REVIEW:  
None

FISCAL IMPACT:  
The Following chart shows a comparison of what the 2023-2024 fiscal year revenue would be for monthly parking if the rate were to remain at the current rate vs. with the new projected rate.

The current Automobile Parking System fund balance as of March 31<sup>st</sup> is \$25,360,625.



			<b>Grand Total</b>	<b>% Increase</b>
Pierce	Projected	<u>2022-2023</u>	\$ 657,840.00	29%
	Proposed	<u>2023-2024</u>	\$ 848,880.00	
Peabody	Projected	<u>2022-2023</u>	\$ 449,160.00	29%
	Proposed	<u>2023-2024</u>	\$ 578,040.00	
Park	Projected	<u>2022-2023</u>	\$ 753,240.00	29%
	Proposed	<u>2023-2024</u>	\$ 969,000.00	
N. Old Woodward	Projected	<u>2022-2023</u>	\$ 720,480.00	29%
	Proposed	<u>2023-2024</u>	\$ 926,880.00	
Chester	Projected	<u>2022-2023</u>	\$ 679,440.00	40%
	Proposed	<u>2023-2024</u>	\$ 952,560.00	
Total	Projected	<u>2022-2023</u>	\$ 3,260,160.00	31%
	Proposed	<u>2023-2024</u>	\$ 4,275,360.00	

**POUBLIC COMMUNICATIONS:**

None

**SUMMARY:**

The City is proposing to increase the monthly parking rate at all five City garages. The proposed rate increase is the first increase in six years. The proposed increase (\$20) except at Pierce, is the same amount that occurred in 2017 and still provides monthly parkers a significant discount from what they would pay if they were to pay the daily rate.

Staff recommended a flat \$20 increase at all five garages, however during review, the Advisory Parking Committee recommended that the monthly rate at the Pierce Garage be increased to \$100 due to the centralized location and popularity of the garage.

The Automobile Parking System Fund, which is an enterprise fund, is in the middle of multiple capital improvement projects over the next five years. Increasing the monthly rate for parking will help pay for these needed repairs and improvements.

**ATTACHMENTS:**

None

**SUGGESTED COMMISSION ACTION:**

Make a motion adopting a resolution amending the Birmingham Fee Schedule to increase the rate for monthly parking at the City's five parking garages from \$50 to \$70 at the Chester St. garage, from \$70 to \$90 at the N. Old Woodward, Park, and Peabody garages, and from \$70 to \$100 at the Pierce garage.

POLICE DEPARTMENT	FEE	PROPOSED FEE	CHANGE CODE	STAFF
<b>Alcohol*:</b>				
Specially Designated Distributor	\$500.00			
Specially Designated Merchant	\$500.00			
<i>*Fee for liquor license inspection may be waived at the discretion of the City Manager where an applicant seeks to change the liquor license by the removal of a licensee from the license and the licensed establishment is not in operation.</i>				
<b>False Alarm fees (74-31):</b>				
First false alarm per calendar year	no charge			
All subsequent false alarms per calendar year	\$50.00			
<b>Fingerprints</b>				
Full set of fingerprints; said fee shall be in addition to any license or permit fee which requires fingerprints to be taken and/or submitted to the Michigan State Police or the Federal Bureau of Investigation	\$10.00			
<b>Parking Meters</b>				
<b>Hourly Meter Rates</b>				
High Demand (Areas Inside Central Core of Business District)	\$1.50			
Lower Demand (Areas Outside Central Core of Business District)	\$1.00			
<b>Meter Bags</b>				
Daily Fee	\$18.00			
<b>Outdoor Dining Metered Space for Platform</b>				
Monthly Outdoor Dining Meter Rental Fee for \$1.00/Hour Meter	\$360.00			
Monthly Outdoor Dining Meter Rental Fee for \$1.50/Hour Meter	\$540.00			
Removal of parking meter housing and/or posts - minimum fee (cost)	\$88.29			
Removal of parking meter housing and/or posts - 1 meter space (cost)	\$264.87			
Removal of parking meter housing and/or posts - 2 meter spaces (cost)	\$441.45			
<b>Parking Offenses &amp; Fines (If paid before 10 days/If paid after 10 days)</b>				
Expired meter: first seven offenses in calendar	\$10/20			
Expired meter: eight offenses or more in calendar year	\$30/40			
Overtime in non-metered zone	\$10/20			
Overtime in a time zone: less than 2 hours	\$15/25			
Overtime in a time zone: 2 hours or longer	\$30/40			
Stopping, standing or parking where prohibited	\$30/40			
Parking over the meter line	\$10/20			
Back into parking lot space	\$10/20			
Keys in ignition or ignition unlocked	\$30/40			
Other illegal parking	\$30/40			
No parking here to corner	\$30/40			
Handicap zone	\$100/125			
Violation of snow emergency parking ordinance	\$50/75			
Illegal parking in permit area	\$30/40			
Illegal parking on private property	\$30/45			
<b>Parking Permits</b>				
<b>Meter Permit Parking (3 Months)</b>				
Lot 6 - Regular	\$210.00			
Lot 6 - Restricted	\$150.00			
Ann St. North	\$180.00			
South Old Woodward	\$120.00			
Lot 11 - NW Corner Maple & Woodward	\$180.00			
Lot 12 - SE Corner Maple & Woodward	\$180.00			
<b>Residential Permit Parking (110-136 - 110-150)</b>				
Residential parking permit per household (includes 2 resident and 3 visitor permits for a two-year period)	\$8.00			
<b>Parking Structure Permit Parking</b>				
Deposit (any cards returned after six-months not eligible for refund)	\$20.00			
<b>Activation fee per AVI card</b>	<b>\$30.00</b>			
Returned checks	\$30.00			
<b>Permit Parking - Chester St. Structure</b>	<b>\$50.00</b>	<b>\$70.00</b>	<b>A</b>	<b>AF</b>
<b>Permit Parking - Pierce St. Structure</b>	<b>\$70.00</b>	<b>\$100.00</b>	<b>A</b>	<b>AF</b>
<b>Permit Parking - All Others</b>	<b>\$70.00</b>	<b>\$90.00</b>	<b>A</b>	<b>AF</b>
<b>Parking Structure Rates</b>				
Less than 2 hours	free			
Less than 3 hours	\$2.00			
Less than 4 hours	\$4.00			
Less than 5 hours	\$6.00			
Less than 6 hours	\$8.00			
Over 6 hours	\$10.00			
Over 7 hours	\$10.00			
Over 8 hours	\$10.00			
Maximum Fee After 10:00PM	\$5.00			
<b>Parking for Valet Licenses</b>				
<b>Valet Parking in City Owned Structures</b>				
Valet parking card deposit, per card	\$20.00			

Fees per car:			
1-100 cars, pre-paying for six months in advance, per month		\$500.00	
101-200 cars, pre-paying for six months in advance, per month		\$750.00	
201 and above cars, pre-paying for six months in advance, per month		\$1,000.00	
<b>Valet Parking Meter</b>			
Valet Monthly Bag fee		\$216.00	
<b><u>Pedi-cabs &amp; Commercial</u></b>			
Annual Application Fee		\$50.00	
Insurance: The owner of every pedicab or commercial quadricycle shall procure and file with the city clerk a liability insurance policy or similar proof of insurance issued by an insurance company authorized to do business in the state. The amount of such liability insurance for each pedicab or commercial quadricycle shall be as follows: An amount of not less than \$2,000,000 because of bodily injury to or death of any one person; in an amount of \$2,000,000 because of bodily injury of two or more persons in any one accident; in an amount of not less than \$2,000,000 in medical coverage for each passenger. Such policy of insurance may be in the form of a separate policy for each pedicab or commercial quadricycle, or may be in the fleet policy covering all pedicabs or commercial quadricycles operated by such owner; provided, however, that such a policy provide for the same amount of liability for each pedicab or commercial quadricycle operated. Provided further, such policy shall name the City of Birmingham as an additional insured, and no such policy as required above may be cancelled until the expiration of 30 days after notice of intent to cancel has been given in writing to the city clerk of the City by registered mail or personal delivery of such notice and a provision to that effect is made a part of such policy.			
<b><u>Precious Metals Dealers 26-161</u></b>			
Annual License Fee		\$500.00	
Annual criminal background check - per person <i>(to be provided by applicant using the Michigan State Police ICHAT system)</i>			
<b><u>Preliminary breath test (PBT) each</u></b>		\$10.00	
<b><u>Stray Animal Fines:</u></b>			
Licensed pet properly immunized, first offense		\$25.00	
Second offense within twelve month period		\$50.00	
<b><u>Vehicle Identification Number Inspection Fee</u></b>		\$25.00	
<b><u>Vehicle Impounding Fee</u></b>		\$25.00	
<b><u>Vehicle Inspection Fee</u></b>		\$25.00	



**NOTICE OF INTENTION TO APPOINT TO THE  
MUSEUM BOARD**

At the regular meeting of Monday, June 26, 2023, the Birmingham City Commission intends to appoint to the Museum Board three regular members to serve a three-year term to expire July 6, 2026, and one alternate member to serve a three-year term to expire July 6, 2026.

Interested parties may submit an application available at the City Clerk's office on or before noon on Wednesday, June 21, 2023. These applications will appear in the public agenda for the regular meeting at which time the commission will discuss recommendations, and may make nominations and vote on appointments.

Board Duties

The Museum Board is charged with collecting, arranging, cataloguing and preserving historical material. The Board may locate and erect plaques or markers at historic sites, buildings or properties in the City of Birmingham with the consent of the owner or owners of any such property and subject to the approval of the City Commission with respect to properties that, in the opinion of the Board, have historic significance. Further, the Board shall have the power to develop, operate and maintain the Allen House as a museum and to exercise authority, control and management over the Hunter House and John West Hunter Memorial Park.

<b>Criteria/Qualifications of Open Position</b>	<b>Date Applications Due (by noon)</b>	<b>Date of Interview</b>
Shall be qualified electors of the City	6/21/2023	6/26/2023

*NOTE: All members of boards and commissions are subject to the provisions of City of Birmingham City Code Chapter 2, Article IX, Ethics and the filing of the Affidavit and Disclosure Statement.*



# MUSEUM BOARD

Chapter 62 - Section 62-26

Terms - Three years - expiring first Monday in July

Eight Members:           Six are electors and appointed by city commission  
                                   One member is an Alternate  
                                   One is owner of a business and appointed by the city manager

The Museum Board is charged with collecting, arranging, cataloguing and preserving historical material. The board may locate and erect plaques or markers at historic sites, buildings or properties in the City of Birmingham with the consent of the owner or owners of any such property and subject to the approval of the city commission with respect to properties that, in the opinion of the board, have historic significance. Further, the board shall have the power to develop, operate and maintain the Allen House as a museum and to exercise authority, control and management over the Hunter House and John West Hunter Memorial Park.

Last Name	First Name	Home Business E-Mail	Appointed	Term Expires
Ashleigh	Caroline	(248)613-4056 <i>info@appraiseyourart.com</i>	12/5/2022 Alternate Member	7/5/2023
Barrett	Kristy Hull	(248)504-1981 <i>kristybarrett1@yahoo.com</i>	4/2/2022 Regular Member	7/5/2023
Erickson	Bev	(248) 561-4178 <i>beverickson@comcast.net</i>	7/26/2021 Regular Member/BHS/Friends	7/5/2024

**BIRMINGHAM HISTORICAL MUSEUM & PARK**, 556 West Maple, Birmingham, MI 48009  
 phone: 248.530.1928 fax: 248.530.1685 [www.bhamgov.org/museum](http://www.bhamgov.org/museum)  
 Leslie Pielack, Museum Director: [lpielack@ci.birmingham.mi.us](mailto:lpielack@ci.birmingham.mi.us)

Last Name	First Name	Home Business E-Mail	Appointed	Term Expires
<b>Harris</b> 2600 Buckingham	<b>Alexandria</b>	(248) 686-4077  <i>akharrisart@gmail.com</i>	7/26/2021 Regular Member/BHS	7/5/2023
<b>Hughes</b> 915 Kennesaw	<b>Patrick J</b>	(248)417-0470  <i>phughes@brickstory.com</i>	9/23/2019 City manager Appointee/Business Owner	7/5/2025
<b>Keefer</b> 505 E. Lincoln #4	<b>Judith</b>	(248)249-0996  <i>jlwk2014@gmail.com</i>	7/11/2016 Regular Member/BHS	7/5/2025
<b>Logue</b> 2010 Buckingham	<b>Marty</b>	(248) 649-4921  <i>gtferos@comcast.net</i>	9/26/2011 Regular Member/BHS/Friends	7/5/2023
<b>Motea</b>	<b>Alex</b>		2/27/2023 Student representative	12/31/2023
<b>Schaufler</b>	<b>Alexandria</b>		2/27/2023 Student representative	12/31/2023
<b>Shell</b> 1121 Northlawn	<b>Jay R.</b>	(248) 890-6333  <i>jay.shell@gmail.com</i>	8/9/2021 Regular Member/BHS/Friends	7/5/2024

**BIRMINGHAM HISTORICAL MUSEUM & PARK**, 556 West Maple, Birmingham, MI 48009  
phone: 248.530.1928 fax: 248.530.1685 [www.bhamgov.org/museum](http://www.bhamgov.org/museum)  
Leslie Pielack, Museum Director: [lpielack@ci.birmingham.mi.us](mailto:lpielack@ci.birmingham.mi.us)



**NOTICE OF INTENTION TO APPOINT TO THE  
GREENWOOD CEMETERY ADVISORY BOARD**

At the regular meeting of Monday, June 5, 2023 the Birmingham City Commission intends to appoint to the Greenwood Cemetery Advisory Board two regular members to serve three-year terms to expire July 6, 2026, and one regular member to serve the remainder of a three-year term to expire July 6, 2024.

Members must be chosen from among the citizens of Birmingham and, insofar as possible, represent diverse interests, such as persons with family members interred in Greenwood Cemetery; owners of burial sites within Greenwood Cemetery intending to be interred in Greenwood Cemetery; persons familiar with and interested in the history of Birmingham; persons with familiarity and experience in landscape architecture, horticulture, law or cemetery or funeral professionals.

Interested citizens may submit a form available at the City Clerk's Office on or before noon on Wednesday, May 31, 2023. These applications will appear in the public agenda for the regular meeting at which time the City Commission will discuss recommendations, and may make nominations and vote on the appointments.

Committee Duties

In general, it shall be the duty of the Greenwood Cemetery Advisory Board to provide recommendations to the City Commission on:

1. Modifications. As to modifications of the rules and regulations governing Greenwood Cemetery.
2. Capital Improvements. As to what capital improvements should be made to the cemetery. Future Demands. As to how to respond to future demands for cemetery services.
3. Day to Day Administration. The day to day administration of the cemetery shall be under the direction and control of the City, through the City Manager or his/her designee.
4. Reports. The Greenwood Cemetery Advisory Board shall make and submit to the City Commission an annual report of the general activities, operation, and condition of the Greenwood Cemetery for the preceding 12 months. The Greenwood Cemetery Advisory Board shall, from time to time, as occasion requires, either in the annual report, or at any time deemed necessary by the Greenwood Cemetery Advisory Board, advise the City Commission in writing on all matters necessary and proper for and pertaining to the proper operation of Greenwood Cemetery and any of its activities or properties.

All members of boards and commissions are subject to the provisions of City of Birmingham City Code Chapter 2, Article IX, Ethics and the filing of the Affidavit and Disclosure Statement.



<b>Criteria/Qualifications of Open Position</b>	<b>Date Applications Due (by noon)</b>	<b>Date of Interview</b>
Must be a resident of Birmingham and, insofar as possible, represent diverse interests, such as persons with family members interred in Greenwood Cemetery; owners of burial sites within Greenwood Cemetery intending to be interred in Greenwood Cemetery; persons familiar with and interested in the history of Birmingham; persons with familiarity and experience in landscape architecture, horticulture, law or cemetery or funeral professionals.	5/31/2023	6/5/2023



# GREENWOOD CEMETERY ADVISORY BOARD

Resolution No. 10-240-14 October 13, 2014.

The Greenwood Cemetery Advisory Board shall consist of seven members who shall serve without compensation. Members must be chosen from among the citizens of Birmingham and, insofar as possible, represent diverse interests, such as persons with family members interred in Greenwood Cemetery; owners of burial sites within Greenwood Cemetery intending to be interred in Greenwood Cemetery; persons familiar with and interested in the history of Birmingham; persons with familiarity and experience in landscape architecture, horticulture, law or cemetery or funeral professionals. The City Manager or his/her designee shall serve as ex official, non-voting members of the Board.

Term: Three years.

In general, it shall be the duty of the Greenwood Cemetery Advisory Board to provide recommendations to the City Commission on:

1. Modifications. As to modifications of the rules and regulations governing Greenwood Cemetery.
2. Capital Improvements. As to what capital improvements should be made to the cemetery.
3. Future Demands. As to how to respond to future demands for cemetery services.
3. Day to Day Administration. The day to day administration of the cemetery shall be under the direction and control of the City, through the City Manager or his/her designee.
4. Reports. The Greenwood Cemetery Advisory Board shall make and submit to the City Commission an annual report of the general activities, operation, and condition of the Greenwood Cemetery for the preceding 12 months. The Greenwood Cemetery Advisory Board shall, from time to time, as occasion requires, either in the annual report, or at any time deemed necessary by the Greenwood Cemetery Advisory Board, advise the City Commission in writing on all matters necessary and proper for and pertaining to the proper operation of Greenwood Cemetery and any of its activities or properties.

Last Name	First Name	Home Address	Home Business E-Mail	Appointed	Term Expires
Buchanan	Linda	1280 Suffield Birmingham	48009  <i>lgbfeb23@gmail.com</i>	(248) 646-3297  12/14/2015 Chair	7/7/2025
DeWeese	Pam	932 Purdy Street Birmingham	48009  <i>pamdeweese@comcast.net</i>	(248) 642-4256  8/24/2020 Plot Owner	7/6/2023

Last Name	First Name	Home Business	Appointed	Term Expires
Home Address		E-Mail		
<b>Peterson</b> 1532 Melton Birmingham	<b>Linda</b> 48009	(248) 894-9010  <i>lpeterson02@comcast.net</i>	11/24/2014 Vice Chair	7/6/2024
<b>Schreiner</b> 591 Bird Birmingham	<b>Laura</b> 48009	(248) 593-0335  <i>laschreiner@yahoo.com</i>	11/24/2014 owner of burial site in Greenwood; person familiar with and interested in the history of Birmingham.	7/6/2024
<b>Suter</b> 1795 Yosemite Birmingham	<b>Margaret</b> 48009	(248) 644-5925  <i>maasuter@gmail.com</i>	5/23/2016 owns a plot, relative buried in Greenwood Cemetery	7/7/2025
<b>Vacated</b>	<b>4/14/2023</b>			7/6/2024
<b>Vercellone</b> 572 W. Lincoln Birmingham	<b>Joseph</b> 48009	(248) 798-0460  <i>jvercellone@gmail.com</i>	8/10/2020 Plot Owner	7/6/2023



**NOTICE OF INTENTION TO APPOINT TO THE  
AD HOC AGING IN PLACE COMMITTEE**

At the regular meeting of Monday, June 26, 2023, the Birmingham City Commission intends to appoint 5 regular members to the Ad Hoc Aging in Place Committee to serve 18-month terms expiring January 31, 2025.

The Ad Hoc Aging in Place Committee consists of seven members appointed by the City Commission. A majority of the members shall be residents of Birmingham and qualified voters. When available, preferred qualifications/areas of professional expertise and experience include: gerontologist, senior health or nutrition, adult education, elder law, representative of Birmingham NEXT, and intergenerational specialist. Staff from the Managers Office will serve as ex-officio member(s) of the committee.

The function of the Ad Hoc Aging in Place Committee (AIP) is to study current demographic trends, evaluate the needs of the City’s aging population, and to prepare a City-wide action plan outlining the vision and goals to improve the health, safety and welfare of senior citizens and encourage residents to age comfortably in Birmingham.

Interested citizens may submit an application available at the City Clerk’s Office or online at [www.bhamgov.org/boardopportunities](http://www.bhamgov.org/boardopportunities). Applications must be submitted to the City Clerk’s Office on or before noon on June 21, 2023. These documents will appear in the public agenda for the regular meeting at which time the City Commission will discuss recommendations, and may make nominations and voter on appointments.

<b>Criteria/Qualifications of Open Position</b>	<b>Date Applications Due (by noon)</b>	<b>Date of Interview</b>
The majority of members must be Birmingham Residents and Electorates. Preferred qualifications / areas of professional expertise and experience include: gerontologist, senior health or nutrition, adult education, elder law, representative of Birmingham NEXT, and intergenerational specialist.	6/21/2023	6/26/2023

*NOTE: All members of boards and commissions are subject to the provisions of City of Birmingham City Code Chapter 2, Article IX, Ethics and the filing of the Affidavit and Disclosure Statement.*



# Ad Hoc Aging in Place Committee

Resolution # 04-093-23

The Ad Hoc Aging in Place Committee consists of seven members appointed by the City Commission. A majority of the members shall be residents of Birmingham and qualified voters. When available, preferred qualifications/areas of professional expertise and experience include: gerontologist, senior health or nutrition, adult education, elder law, representative of Birmingham NEXT, and intergenerational specialist. Staff from the Managers Office will serve as ex-officio member(s) of the committee.

The function of the Ad Hoc Aging in Place Committee (AIP) is to study current demographic trends, evaluate the needs of the City's aging population, and to prepare a City-wide action plan outlining the vision and goals to improve the health, safety and welfare of senior citizens and encourage residents to age comfortably in Birmingham.

Last Name	First Name	Home Business	Home Address	E-Mail	Appointed	Term Expires
<b>Ex-Officio From Manager's Office</b>						1/31/2025
<b>Representative from Baldwin Library</b>						1/31/2025
<b>Representative of Birmingham Museum</b>						1/31/2025

Last Name	First Name	Home Business E-Mail	Appointed	Term Expires
Vacant			Representative of NEXT Senior Services	1/31/2025
Vacant			Intergenerational Connection	1/31/2025
Vacant			Gerontologist / Aging Specialist	1/31/2025
Vacant			Elder Law / Estate Planning	1/31/2025
Vacant			Senior Health/ Nutrition	1/31/2025



**NOTICE OF INTENTION TO APPOINT TO THE  
BOARD OF ETHICS**

At the regular meeting of Monday, June 26, 2023 the Birmingham City Commission intends to appoint one regular member to the Board of Ethics to serve a three-year term to expire June 30, 2026.

Board members are to serve as an advisory body for the purposes of interpreting the Code of Ethics. The board consists of three regular members and two alternates who serve without compensation. The members shall be residents and have legal, administrative or other desirable qualifications.

Interested citizens may submit an application available at the City Clerk’s office or online at [www.bhamgov.org/boardopportunities](http://www.bhamgov.org/boardopportunities). Applications must be submitted to the City Clerk's office on or before noon on Wednesday, June 21, 2023. These documents will appear in the public agenda for the regular meeting at which time the City Commission will discuss recommendations, and may make nominations and vote on appointment.

<b>Criteria/Qualifications of Open Position</b>	<b>Date Applications Due (by noon)</b>	<b>Date of Interview</b>
Members shall be residents and have legal, administrative or other desirable qualifications.	6/21/2023	6/28/2023

*NOTE: All members of boards and commissions are subject to the provisions of City of Birmingham City Code Chapter 2, Article IX, Ethics and the filing of the Affidavit and Disclosure Statement.*



# BOARD OF ETHICS

Ordinance 1805 Birmingham Code of Ordinances Sec. 2-320 through 2-326  
 Ordinance 1805, Ordinance 2378

The board shall serve as an advisory body for purposes of interpreting the Code of Ethics. The board consists of three regular members and two alternate members who serve without compensation. The members shall be residents and have legal, administrative, or other desirable qualifications.

Last Name	First Name	Home Business E-Mail	Appointed	Term Expires
<b>Fierro-Share</b> 1040 Gordon Lane	<b>Sophie</b>	(248) 642-7340 <i>Sfierro-share1@comcast.net</i>	7/14/2003	6/30/2023
<b>Robb</b> 1533 Pleasant Court	<b>James</b>	(517)712-3469 <i>jamesdrobb55@gmail.com</i>	8/11/2003	6/30/2025
<b>Schrot</b> 1878 Fairway	<b>John</b>	(248) 646-6513 <i>jschrot@berrymoorman.com</i>	7/14/2003	6/30/2024
<b>Vacant</b>				6/30/2026 Alternate Member
<b>Vacant</b>				6/30/2026 Alternate Member





**NOTICE OF INTENTION TO APPOINT TO  
PUBLIC ARTS BOARD**

At the regular meeting of Monday, June 26, 2023, the Birmingham City Commission intends to appoint to the Public Arts Board one regular member to serve the remainder a three-year term to expire January 28, 2025, and one alternate member to serve a three-year term to expire January 28, 2025.

In so far as possible, the members shall represent a major cultural institution, a registered architect of the State of Michigan, an artist, an art historian, and an art consultant. Members may also be members of the Historic District Commission, Design Review Board, the Parks and Recreation Board, or the Planning Board. At least four members of the Board shall be residents of the City of Birmingham.

The objectives of the Public Arts Board are to enrich the City's civic and cultural heritage; to promote a rich, diverse, and stimulating cultural environment in order to enrich the lives of the City's residents, business owners, employees, and all visitors; and to establish an environment where differing points of view are fostered, expected, and celebrated by providing the opportunity for such expression through the display of public art.

Interested citizens may apply for this position by submitting an application available from the City Clerk's office. Applications must be submitted to the City Clerk's office on or before noon on Wednesday, January 19, 2023. These applications will appear in the public agenda for the regular meeting at which time the commission will discuss recommendations, and may make nominations and vote on the appointments.

<b>Criteria/Qualifications of Open Position</b>	<b>Date Applications Due (by noon)</b>	<b>Date of Interview</b>
<p>Members shall, in so far as possible, represent a major cultural institution, a registered architect of the State of Michigan, an artist, an art historian, and an art consultant. Members may also be members of the Historic District Commission, Design Review Board, the Parks and Recreation Board, or the Planning Board.</p> <p>At least four members of the Board shall be residents of the City of Birmingham.</p>	6/21/2023	6/26/2023

*All members of boards and commissions are subject to the provisions of City of Birmingham City Code Chapter 2, Article IX, Ethics and the filing of the Affidavit and Disclosure Statement.*



# PUBLIC ARTS BOARD

City Code - Chapter 78, Article V

Terms - 3 years

7 regular members - At least 4 members shall be residents of the City of Birmingham. The remaining members may or may not be residents of Birmingham. In so far as possible, the members shall represent a major cultural institution, a registered architect of the State of Michigan, an artist, an art historian, and an art consultant. Members may also be members of the Historic District Commission, Design Review Board, the Parks and Recreation Board, or the Planning Board.

2 alternate members - must meet one of the already established criteria for regular members

Objectives -

- to enrich the City's civic and cultural heritage;
- to promote a rich, diverse, and stimulating cultural environment in order to enrich the lives of the City's residents, business owners, employees, and all visitors;
- to establish an environment where differing points of view are fostered, expected, and celebrated by providing the opportunity for such expression through the display of public art.

Last Name	First Name	Home Business	E-Mail	Appointed	Term Expires
<b>Andi</b>	<b>Harris</b>		(248)765-3202	3/27/2023	1/28/2026
1819 Washington Blvd				Alternate Member	
Birmingham	48009		<i>andi.celeste.harris@gmail.com</i>		
<b>DeSanto</b>	<b>Luca</b>			2/27/2023	12/31/2023
				Student representative	
<b>Eddleston</b>	<b>Jason</b>		(248) 703-3808	12/5/2016	1/28/2025
892 Purdy				Resident Member	
Birmingham	48009		<i>jason28e@yahoo.com</i>		
<b>Graham</b>	<b>Pam</b>		(248) 408-6277	2/27/2023	1/28/2026
884 Knox				Regular member	
Birmingham	48009		<i>pamcracker@gmail.com</i>		

Last Name Home Address	First Name	Home Business E-Mail	Appointed	Term Expires
<b>Heller</b> 176 Linden Birmingham	<b>Barbara</b>  48009	(248) 540-1310 (313) 833-7834 <i>bheller@dia.org</i>	1/28/2002 Resident Member	1/28/2024
<b>McLean</b>	<b>Andrew</b>		2/27/2023 Student representative	12/31/2023
<b>Neville</b> 1516 E. Melton Birmingham	<b>Monica</b>  48009	(248) 321-1776  <i>monica.neville1@gmail.com</i>	2/27/2017 Resident Member	1/28/2024
<b>Ritchie</b> 1455 South Eton Birmingham	<b>Anne</b>  48009	(248) 635-1765  <i>anneritchie7@yahoo.com</i>	9/12/2016 Resident Member	1/28/2025
<b>Vacant</b>	<b>Vacated 1/2020</b>			1/28/2025 Alternate Member
<b>Vacated</b>	<b>4/21/2023</b>			1/28/2025 Regular Member
<b>VanGeldereren</b> 3795 Loch Bend Commerce Twp.	<b>Annie</b>  48382	(248) 408-6132  <i>annievangeldereren@bbartcenter.org</i>	1/13/2020 Artist/Major Cultural Institution	1/28/2026

**BIRMINGHAM AREA CABLE BOARD  
ANNUAL REPORT  
FISCAL YEAR 2021-22**

**Submitted By:**

**Cathy K. White**

**Executive Director**

**December, 2022**

# **CABLE BOARD MEMBERS**

**As of December 31, 2022**

## **BIRMINGHAM**

**Michael Fenberg-Treasurer**

**David Eick- Vice Chair & Personnel Committee Chair**

**George Abraham- Cable Action Committee Chair**

**Donovan Shand**

**Jim Cleary**

**Robert Whittington**

## **BINGHAM FARMS**

**D.E. Hagaman**

## **FRANKLIN**

**Rick David**

## **BEVERLY HILLS**

**Christopher Dobies**

**Gilbert Gugni- Chairman**

**Shane Henry**

**Ray Kamoo- Secretary & PEG Committee Chair**

## **Introduction**

Each year upon the completion of the BACB annual audit, prepared by Plante & Moran, PLLC, we submit an update to our four community members: Birmingham, Beverly Hills, Franklin and Bingham Farms. The purpose of this annual report is to keep these communities apprised of the work of the BACB during the previous calendar year.

As Chairman of the BACB I am pleased to report that during the previous year we have continued to perform our mandated duties with great pride and distinction. Franchise fees have been timely paid to the community members in the form of administrative grants. Grant requests have been received and moved upon in a speedy and effective process. All complaints received from residents regarding service from the three providers (Comcast, AT&T and WOW) were resolved expeditiously, primarily due to the efforts of the BACB's Executive Director, Cathy White.

By the end of this reporting period, all twelve positions of the BACB were filled for the first time since prior to the start of the pandemic. These twelve individuals are highly motivated to continue the duties and responsibilities of the BACB in a professional manner. I am very confident that this will occur.

Gil Gugni  
Chairman, Birmingham Area Cable Board

## **BCTV Contract**

The contract with BCTV for public and governmental programming, which originally expired on June 30, 2019, has been extended until December 31, 2026. Carrie LeZott currently serves as Director of Cable and Community Relations and Greg Black currently serves as manager. The cost for BACB production and associated services in FY 2021-22 was \$262,350.00. BCTV has been taping three additional Birmingham public meetings: the Board of Zoning Appeals, the Advisory Parking Committee and the Multi-Modal Transportation Board. In addition, we utilize PEG funds for BCTV to tape local high school sports events.

## **Board Committees**

The Board has three standing committees: PEG (Public Educational Governmental), CAC (Cable Action) and Personnel committees.

## **PEG Committee**

The PEG Committee is charged with oversight and development of programming on the public access and governmental channels as well as reviewing proposed grants for PEG infrastructure. Ray Kamoo is the Chairman; membership is open to any Board member, and representatives of BCTV and the Birmingham Public Schools participate on a regular basis. Live broadcast, as well as rebroadcast, of local governmental meetings continues on the Governmental channel. The Public channel provides opportunities for local citizens to produce their own programs, as well as to broadcast/rebroadcast parades, lectures, concerts and other events of community interest. The rebroadcast of Groves versus Seaholm athletic contests, both boys and girls, is now in its ninth year and is an especially popular undertaking. Comprising its contribution to the "E" in PEG, the Cable Board has made significant contributions to help fund the broadcast infrastructure for the Birmingham Public Schools and, specifically, the Birmingham Public School Education and Administration Center. We are actively

seeking new PEG grant requests to include community equipment upgrades and enhancements to the school facilities within our footprint.

### **CAC Committee**

The Cable Action Committee was formed to follow up on Board initiatives and cable provider commitments at the monthly meetings and drive special projects. Subscriber complaints are reviewed, and legal/legislative issues and new initiatives are discussed. George Abraham is the Chairman. Discussions involved PEG and municipal support services grants, financial matters, cable TV industry developments, review and improvement of the new BACB website, FCC rule-making proceedings and long-term planning. We are continuing to expand our outreach to assist more members of the community in resolving customer service issues.

### **Personnel Committee**

The Personnel Committee was formed to address personnel issues, fill Board vacancies and complete performance evaluations of the Executive Director. David Eick is the Chairman. The Personnel Committee met in May of 2022 to conduct the annual review of the Executive Director's job performance.

### **Audit**

Plante & Moran, PLLC conducted the annual audit of Board financial operations. The audit included a review of the financial activities performed by Beverly Hills, which acts as the BACB fiduciary agent. The audit also reviewed activity on the Michigan United Credit Union (designated funds to purchase capital equipment for PEG-related activities) and our Multi Bank Securities account (institutional investments). The Independent Auditor's Report indicated that the BACB's financial statements received an unmodified audit opinion for 2021-2022, which is the highest level given.

### **Grants**

The Board paid a total of \$3,158.00 in grants during the fiscal year. This amount includes a municipal support services grant to the Franklin Bingham Fire Department in the amount of \$2,699. A PEG grant was awarded to the Village of Beverly Hills for work done by a contractor (Advanced Lighting & Sound) to enable hybrid meetings to be conducted as a result of the global pandemic.

In addition, Administrative Grants from franchise fees, per our Interlocal Agreement, were also returned proportionally to each BACB community.

### **Complaints**

Written complaints to the BACB decreased in FY 2021-22. There were approximately 28 formal complaints, compared to 40 complaints the previous year. Our Executive Director accepts all calls and website complaints including informal actions wherein residents decline to record formal action. Complaints involved pricing/billing, poor service, service interruptions, long wait times on Comcast 1-800 numbers, calls being shifted overseas, missed appointments (without compensation) and downed/unburied wires in the rights-of-way. Subscribers are still encouraged to call their provider first to try to resolve disputes. The BACB continues to accept and process complaints from our residents. We

have streamlined the escalation process. WOW!, Comcast and AT&T have escalation teams to promptly deal with residents' problems and are often resolved within 24 hours.

The Michigan Public Service Commission also addresses complaints against cable providers (as well as disputes between local units of government and cable providers). The MPSC process is rather difficult and time-consuming for residents; the BACB, however, continues to address all local complaints immediately.

### **Fiscal Year Budget**

The Board is expected to receive \$688,005.00 in franchise and PEG fees this upcoming fiscal year. This includes \$248,005.00 in franchise fees and \$440,000.00 in PEG fees. PEG fees are designated funds and may only be used for purchase and maintenance of capital equipment.



**Birmingham Area Cable Board  
Proposed Budget  
Year Ended June 30, 2023**

	<b>Current Budget</b>	<b>Proposed Budget</b>
	<b>Year Ended June 30, 2022</b>	<b>Year Ended June 30, 2023</b>
<b>Franchise Fee Income:</b>		
Beverly Hills Franchise Fee	43,320	60,000
Bingham Farms Franchise Fee	7,600	12,626
Birmingham Franchise Fee	157,225	158,374
Franklin Franchise Fee	17,005	17,005
<b>Total Franchise Fee Income</b>	<b>225,150</b>	<b>248,005</b>
<b>Board Expenses:</b>		
Accounting Expenses	2,400	2,400
Administrative Grants	96,390	120,145
Advertising - Community Outreach	500	500
Bank Service Charges	60	60
Conferences	900	900
Contract labor	1,500	1,000
Executive Director	40,000	40,000
HR Services	900	1,100
Insurance	3,000	3,000
Mileage	800	700
Memberships	1,500	1,500
Office Expense	4,500	4,500
Telephone	1,100	1,100
Website	3,500	3,500
Auditing	9,500	12,000
Legal Fees	28,000	25,000
Technical Support	600	600
<b>Total Board Expenses</b>	<b>195,150</b>	<b>218,005</b>
Municipal Support Services	30,000	30,000
<b>Total Franchise Fee Expenses</b>	<b>225,150</b>	<b>248,005</b>
<b>Net Franchise Fee Income</b>	<b>0</b>	<b>0</b>
<b>PEG Revenue:</b>		
<b>Total PEG Revenue</b>	<b>396,125</b>	<b>440,000</b>
<b>Other Income</b>		
Interest Income	25	15
Other Income	1,000	100
MBS Gains	6,100	900
<b>Total PEG Income</b>	<b>403,250</b>	<b>441,015</b>
<b>PEG Operations</b>		
Cable Contractor	245,800	308,300
Communications Expense	2,200	5,000
Equipment Purchases	20,000	3,000
Grants	84,800	78,000
Production Truck	10,000	198,015
Production Crew Uniforms	450	1,000
Program Expense	40,000	40,000
<b>Total PEG Operations</b>	<b>403,250</b>	<b>633,315</b>
<b>Net PEG Income</b>	<b>0</b>	<b>(192,300)</b>
<b>Anticipated drawdown from Fund Equity</b>		<b>192,300</b>

---

# Birmingham Area Cable Board

---

**Financial Report  
with Supplemental Information  
June 30, 2022**

# Birmingham Area Cable Board

---

## Contents

---

<b>Independent Auditor's Report</b>	1-2
<b>Management's Discussion and Analysis</b>	3-5
<b>Basic Financial Statements</b>	
General Fund Balance Sheet/Statement of Net Position	6
Statement of General Fund Revenue, Expenditures, and Changes in Fund Balance/Statement of Activities	7
Notes to Financial Statements	8-14
<b>Required Supplemental Information</b>	15
Budgetary Comparison Schedule - General Fund	16
Note to Required Supplemental Information	17

## Independent Auditor's Report

To the Board Members  
Birmingham Area Cable Board

### **Opinions**

We have audited the financial statements of the governmental activities and the General Fund of Birmingham Area Cable Board (the "Board") as of and for the year ended June 30, 2022 and the related notes to the financial statements, which collectively comprise the Board's basic financial statements, as listed in the table of contents.

In our opinion, the accompanying financial statements referred to above present fairly, in all material respects, the respective financial position of the governmental activities and the General Fund of the Board as of June 30, 2022 and the respective changes in its financial position for the year then ended in accordance with accounting principles generally accepted in the United States of America.

### **Basis for Opinions**

We conducted our audit in accordance with auditing standards generally accepted in the United States of America (GAAS). Our responsibilities under those standards are further described in the *Auditor's Responsibilities for the Audit of the Financial Statements* section of our report. We are required to be independent of the Board and to meet our other ethical responsibilities in accordance with the relevant ethical requirements relating to our audit. We believe that the audit evidence we have obtained is sufficient and appropriate to provide a basis for our audit opinions.

### **Responsibilities of Management for the Financial Statements**

Management is responsible for the preparation and fair presentation of the financial statements in accordance with accounting principles generally accepted in the United States of America and for the design, implementation, and maintenance of internal control relevant to the preparation and fair presentation of financial statements that are free from material misstatement, whether due to fraud or error.

In preparing the financial statements, management is required to evaluate whether there are conditions or events, considered in the aggregate, that raise substantial doubt about the Board's ability to continue as a going concern for 12 months beyond the financial statement date, including any currently known information that may raise substantial doubt shortly thereafter.

### **Auditor's Responsibilities for the Audit of the Financial Statements**

Our objectives are to obtain reasonable assurance about whether the financial statements as a whole are free from material misstatement, whether due to fraud or error, and to issue an auditor's report that includes our opinions. Reasonable assurance is a high level of assurance but is not absolute assurance and, therefore, is not a guarantee that an audit conducted in accordance with GAAS will always detect a material misstatement when it exists. The risk of not detecting a material misstatement resulting from fraud is higher than for one resulting from error, as fraud may involve collusion, forgery, intentional omissions, misrepresentations, or the override of internal control. Misstatements are considered material if there is a substantial likelihood that, individually or in the aggregate, they would influence the judgment made by a reasonable user based on the financial statements.

To the Board Members  
Birmingham Area Cable Board

In performing an audit in accordance with GAAS, we:

- Exercise professional judgment and maintain professional skepticism throughout the audit.
- Identify and assess the risks of material misstatement of the financial statements, whether due to fraud or error, and design and perform audit procedures responsive to those risks. Such procedures include examining, on a test basis, evidence regarding the amounts and disclosures in the financial statements.
- Obtain an understanding of internal control relevant to the audit in order to design audit procedures that are appropriate in the circumstances but not for the purpose of expressing an opinion on the effectiveness of the Board's internal control. Accordingly, no such opinion is expressed.
- Evaluate the appropriateness of accounting policies used and the reasonableness of significant accounting estimates made by management, as well as evaluate the overall presentation of the financial statements.
- Conclude whether, in our judgment, there are conditions or events, considered in the aggregate, that raise substantial doubt about the Board's ability to continue as a going concern for a reasonable period of time.

We are required to communicate with those charged with governance regarding, among other matters, the planned scope and timing of the audit, significant audit findings, and certain internal control-related matters that we identified during the audit.

***Required Supplemental Information***

Accounting principles generally accepted in the United States of America require that the management's discussion and analysis and other required supplemental information, as identified in the table of contents, be presented to supplement the basic financial statements. Such information is the responsibility of management and, although not a part of the basic financial statements, is required by the Governmental Accounting Standards Board, which considers it to be an essential part of financial reporting for placing the basic financial statements in an appropriate operational, economic, or historical context. We have applied certain limited procedures to the required supplemental information in accordance with auditing standards generally accepted in the United States of America, which consisted of inquiries of management about the methods of preparing the information and comparing the information for consistency with management's responses to our inquiries, the basic financial statements, and other knowledge we obtained during our audit of the basic financial statements. We do not express an opinion or provide any assurance on the information because the limited procedures do not provide us with sufficient evidence to express an opinion or provide any assurance.

*Plante & Morse, PLLC*

October 31, 2022

Our discussion and analysis of Birmingham Area Cable Board's (the "Board") financial performance provides an overview of the Board's financial activities for the fiscal year ended June 30, 2022. Please read it in conjunction with the Board's financial statements.

**Using This Annual Report**

This annual report consists of three parts: (1) management's discussion and analysis (this section), (2) the basic financial statements, and (3) required supplemental information. The financial statements also include notes that explain some of the information in the financial statements and provide more detailed data. The statements are followed by a section of required supplemental information that further explains and supports the information in the financial statements.

The basic financial statements include information that presents two different views of the Board:

- The first column of the financial statements includes information on the Board's General Fund under the modified accrual method. These fund financial statements focus on current financial resources and provide a more detailed view about the accountability of the Board's sources and uses of funds.
- The adjustments column of the financial statements represents adjustments necessary to convert the fund financial statements to the government-wide financial statements under the full accrual method of accounting.
- The third column presents the Board's operations on a full accrual basis, which provides both long- and short-term information about the Board's overall financial status. The statement of net position and the statement of activities provide information about the activities of the Board as a whole and present a longer-term view of the Board's finances.

**Condensed Financial Information**

The following tables show key financial information in a condensed format for the government-wide statements of net position and activities:

	2022	2021
<b>Assets</b>		
Current and other assets	\$ 1,587,364	\$ 1,665,646
Capital assets - Net	191,468	178,880
Total assets	1,778,832	1,844,526
<b>Liabilities - Accounts payable</b>	924	12,912
<b>Net Position</b>		
Net investment in capital assets	191,468	178,880
Restricted for public, education, and government (PEG)	1,088,487	1,067,572
Unrestricted	497,953	585,162
Total net position	\$ 1,777,908	\$ 1,831,614

## Birmingham Area Cable Board

### Management's Discussion and Analysis (Continued)

	2022	2021
<b>Revenue</b>		
Franchise fees	\$ 335,751	\$ 343,585
PEG fees	339,483	358,849
Investment (loss) income	(43,253)	1,374
Total revenue	631,981	703,808
<b>Expenditures</b>		
PEG operations	306,680	372,318
Board expenditures	379,007	169,779
Total expenditures	685,687	542,097
<b>Net Change in Net Position</b>	(53,706)	161,711
<b>Net Position - Beginning of year</b>	1,831,614	1,669,903
<b>Net Position - End of year</b>	<u>\$ 1,777,908</u>	<u>\$ 1,831,614</u>

#### ***The Board as a Whole***

- The Board reports a net position of \$1,777,908 this year on a full accrual basis, as compared to a fund balance of \$1,409,086 on the modified accrual basis of accounting.
- The Board recorded accounts payable of \$924 in the current year and \$12,912 in the prior year.
- The Board's primary source of revenue is from franchise and PEG fees. For 2022, total fees collected were \$675,234. This represents the majority of revenue.
- The largest expenditure of the Board, other than the issuance of grants, is for the agreement with Bloomfield Community Television (BCTV). For 2022, this expenditure was \$262,350, representing approximately 38 percent of the General Fund's total expenditures.
- Expenses for PEG operations decreased by \$65,638, or 17.6 percent. This decrease is primarily due to a decrease in PEG grant disbursements in the current year.
- Expense for board operations increased by \$209,228, or 123.2 percent. This increase is primarily due to an increased amount of unspent franchise fees distributed back to the communities.
- Total expenditures for the entire year under the modified accrual basis of accounting were \$698,275.

#### ***The General Fund***

Our analysis of the Board's General Fund is included on pages 6 and 7 in the first column of the respective statements. The fund column provides detailed information about the General Fund on a modified accrual method, which is a short-term perspective measuring the flow of financial resources, not the Board's operations on a full accrual basis of accounting, which provides a longer-term measurement of total economic resources. The Board's only fund is the General Fund. The fund balance of the General Fund decreased by \$220,318 during the year.

#### ***Board Budgetary Highlights***

The Board's budget for revenue for 2022 was \$628,400, with actual revenue coming in at \$477,957. Franchise fees came in higher than anticipated, and PEG fees came in lower than anticipated. As of June 30, 2022, the Board has \$177,354 in unavailable revenue, which is due to receiving the fees from the communities after the period of availability. The unavailable revenue will be recognized as revenue in the next fiscal year. On the expenditure side, the total budget was \$868,540, and actual expenditures were \$698,275. The variance is primarily due to fewer expenditures for grants, program expenses, professional fees, and municipal support services.

## **Birmingham Area Cable Board**

---

### **Management's Discussion and Analysis (Continued)**

---

#### ***Capital Assets and Debt Administration***

At year end, the Board had \$191,468 invested in the production van and equipment. In 2022, the Board had \$38,024 of additions and \$0 of disposals of equipment.

The Board carries no long-term debt.

#### ***Economic Factors and Next Year's Budgets and Rates***

The Board's revenue budget for fiscal year 2023 increased from the fiscal year 2022 results. The Board believes consumer spending on traditional cable television will slow due to the increase in popularity and availability of streaming services, which are not subject to the requirement to pay franchise or PEG fees. The potential loss of revenue from franchise and PEG fees may be offset, however, by the providers' annual increases in cable television rates charged to consumers who have chosen to remain as traditional cable subscribers. The Board is monitoring new rules promulgated by the Federal Communications Commission (FCC) that may reduce PEG revenue. The Board will continue to exercise fiscal discipline with respect to board operating expenses, resulting in a return of uncommitted franchise fee revenue to each of the participating municipalities at the end of the fiscal year as a dividend from shared municipal services. PEG revenue will be managed in accordance with parameters outlined in applicable state and federal statutes.

#### ***Requests for Further Information***

If you have questions about this report or need additional information, we welcome you to contact Cathy White at 248-336-9445 or via email at [exec@birminghamareacableboard.org](mailto:exec@birminghamareacableboard.org).



# Birmingham Area Cable Board

## General Fund Balance Sheet/Statement of Net Position

June 30, 2022

	General Fund - Modified Accrual Basis	Adjustments (Note 7)	Statement of Net Position - Full Accrual Basis
<b>Assets</b>			
Cash and investments (Notes 2 and 3)	\$ 1,052,356	\$ -	\$ 1,052,356
Amount on deposit at the Village of Beverly Hills, Michigan (Note 4)	202,198	-	202,198
Due from service providers for franchise and PEG fees	329,839	-	329,839
Other receivables	2,971	-	2,971
Capital assets - Net (Note 5)	-	191,468	191,468
<b>Total assets</b>	<b><u>\$ 1,587,364</u></b>	191,468	1,778,832
<b>Liabilities - Accounts payable</b>	\$ 924	-	924
<b>Deferred Inflows of Resources - Unavailable revenue</b>	177,354	(177,354)	-
<b>Equity</b>			
Fund balance:			
Restricted - Public, education, and government	999,158	(999,158)	-
Committed - Franchise fees to communities	171,238	(171,238)	-
Unassigned	238,690	(238,690)	-
<b>Total fund balance</b>	<b><u>1,409,086</u></b>	<b><u>(1,409,086)</u></b>	<b><u>-</u></b>
<b>Total liabilities, deferred inflows of resources, and fund balance</b>	<b><u>\$ 1,587,364</u></b>		
<b>Net position:</b>			
Net investment in capital assets		191,468	191,468
Restricted for public, education, and government		1,088,487	1,088,487
Unrestricted		497,953	497,953
<b>Total net position</b>		<b><u>\$ 1,777,908</u></b>	<b><u>\$ 1,777,908</u></b>

See notes to financial statements.

## Birmingham Area Cable Board

### Statement of General Fund Revenue, Expenditures, and Changes in Fund Balance/Statement of Activities

Year Ended June 30, 2022

	General Fund - Modified Accrual Basis	Adjustments (Note 7)	Statement of Activities - Full Accrual Basis
<b>Revenue</b>			
Franchise fees:			
Birmingham, Michigan	\$ 157,857	\$ 50,949	\$ 208,806
Beverly Hills, Michigan	80,408	-	80,408
Franklin Village, Michigan	-	29,602	29,602
Bingham Farms, Michigan	21,031	(4,096)	16,935
PEG fees:			
Birmingham, Michigan	158,532	51,644	210,176
Beverly Hills, Michigan	82,063	-	82,063
Franklin Village, Michigan	-	30,081	30,081
Bingham Farms, Michigan	21,319	(4,156)	17,163
Investment loss	(43,253)	-	(43,253)
Total revenue	477,957	154,024	631,981
<b>Expenditures</b>			
PEG operations:			
Cable contractor	262,350	-	262,350
Communications expense	5,766	-	5,766
Grants	459	-	459
Production truck	590	-	590
Program expense	10,000	-	10,000
Equipment	40,103	(38,024)	2,079
Depreciation	-	25,436	25,436
Board expenditures:			
Administrative grants	299,962	-	299,962
Conferences	679	-	679
Contract labor	763	-	763
Executive director	39,862	-	39,862
Liability insurance	2,795	-	2,795
Memberships	1,000	-	1,000
Operating expense	7,417	-	7,417
Professional fees	23,580	-	23,580
Advertising/Promotion	250	-	250
Municipal support services	2,699	-	2,699
Total expenditures	698,275	(12,588)	685,687
<b>Net Change in Fund Balance/Net Position</b>	(220,318)	166,612	(53,706)
<b>Fund Balance/Net Position - Beginning of year</b>	1,629,404	202,210	1,831,614
<b>Fund Balance/Net Position - End of year</b>	<u>\$ 1,409,086</u>	<u>\$ 368,822</u>	<u>\$ 1,777,908</u>

See notes to financial statements.

**June 30, 2022****Note 1 - Significant Accounting Policies*****Reporting Entity***

Birmingham Area Cable Board (the "Board") was created through an interlocal agreement between the City of Birmingham, Michigan and the villages of Beverly Hills, Bingham Farms, and Franklin, Michigan (collectively, the "Parties"). The Board was organized to obtain for the Parties the economies of scale implicit in combining cable revenue and sharing cable expenses, rather than independently operating separate facilities. The Board is composed of 13 members: 7 representatives are appointed by the City of Birmingham, Michigan; 4 representatives are appointed by the Village of Beverly Hills, Michigan; 1 representative is from the Village of Bingham Farms, Michigan; and 1 representative is from the Village of Franklin, Michigan. The accompanying financial statements present Birmingham Area Cable Board's assets and liabilities. No other component units have been combined into the Board's basic financial statements.

***Accounting and Reporting Principles***

The Board follows accounting principles generally accepted in the United States of America (GAAP), as applicable to governmental units. Accounting and financial reporting pronouncements are promulgated by the Governmental Accounting Standards Board. The following is a summary of the significant accounting policies used by the Board:

***Report Presentation***

Governmental accounting principles require that financial reports include two different perspectives - the government-wide perspective and the fund-based perspective. The General Fund column presents its activities on the modified accrual basis of accounting, as discussed above, which demonstrates accountability for how the current resources have been spent. The government-wide column is presented on the economic resources measurement focus and the full accrual basis of accounting in order to measure the cost of providing government services and the extent to which constituents have paid the full cost of government services.

On the full accrual basis of accounting, revenue is recorded when earned, and expenses are recorded when a liability is incurred, regardless of the timing of related cash flows.

***Fund Accounting***

The Board accounts for its activities in one governmental fund. The General Fund is the primary operating fund and accounts for all financial resources used to provide services.

***Basis of Accounting***

The General Fund uses the current financial resources measurement focus and the modified accrual basis of accounting. This basis of accounting is intended to better demonstrate accountability for how the Board has spent its resources.

Expenditures are reported when the goods are received or the services are rendered. Capital outlays are reported as expenditures (rather than as capital assets) because they reduce the ability to spend resources in the future.

Revenue is not recognized until it is collected or collected soon enough after the end of the year that it is available to pay for obligations outstanding at the end of the year. For this purpose, the Board considers amounts collected within 60 days of year end to be available for recognition. Some franchise and PEG fee revenue may be collected after the period of availability; receivables have been recorded for these, along with a deferred inflow.

**Note 1 - Significant Accounting Policies (Continued)**

***Specific Balances and Transactions***

**Cash and Investments**

Cash and cash equivalents include cash on hand, demand deposits, and short-term investments with a maturity of three months or less when acquired. Investments are stated at fair value.

**PEG Activity**

The Board has established two channels, one for public and a second for government broadcast. The Birmingham Public School District operates a third educational channel. The three channels are commonly referred to as PEG channels. The public and governmental channels are administered by the Board, and the educational channel is administered by the Birmingham Public School District. In order to fund the administration of the public and governmental channels, the Board receives financial support in the form of PEG fees from its cable providers in the amount of 2-3 percent of the cable providers' gross revenue in each community. By state and federal law, these funds are restrictively dedicated for use on PEG-related projects. A portion of these PEG fees can be and is allocated to the Parties and Birmingham Public School District upon a grant request. The unused portion as of the end of the year has been classified as restricted fund balance/net position.

**Capital Assets**

Capital assets, which include equipment and vehicles, are reported in the governmental activities column in the government-wide financial statements. Capital assets are defined by the Board as assets with an initial individual cost of more than \$500 and an estimated useful life in excess of one year. Such assets are recorded at historical cost or estimated historical cost if purchased or constructed. Donated capital assets are recorded at estimated acquisition value at the date of donation.

Capital assets are depreciated using the straight-line method over the following useful lives:

<u>Capital Asset Class</u>	<u>Depreciable Life</u>
Production van	5 to 20 years
Equipment	5 to 10 years

**Deferred Outflows/Inflows of Resources**

In addition to assets, the statement of net position and/or balance sheet will sometimes report a separate section for deferred outflows of resources. This separate financial statement element represents a consumption of net position that applies to future periods and will not be recognized as an outflow of resources (expense/expenditure) until then. The Board had no deferred outflows of resources.

In addition to liabilities, the statement of net position and/or balance sheet will sometimes report a separate section for deferred inflows of resources. This separate financial statement element represents an acquisition of net position that applies to future periods and will not be recognized as an inflow of resources (revenue) until that time. Unavailable revenue qualifies for reporting in this category and arises only under a modified accrual basis of accounting. Unavailable revenue is reported only on the General Fund balance sheet. The General Fund reports unavailable revenue from franchise and PEG fees. These amounts are deferred and recognized as an inflow of resources in the period that the amounts become available.

**Net Position Flow Assumption**

The Board will sometimes fund outlays for PEG purposes from both restricted and unrestricted resources. In order to calculate the amounts to report as restricted net position and unrestricted net position in the government-wide financial statements, a flow assumption must be made about the order in which the resources are considered to be applied. It is the Board's policy to consider PEG restricted net position to have been depleted before unrestricted net position is applied.

**Note 1 - Significant Accounting Policies (Continued)**

**Fund Balance Flow Assumptions**

The Board will sometimes fund outlays for PEG purposes from both restricted and unrestricted resources (the total of committed, assigned, and unassigned fund balance). In order to calculate the amounts to report as restricted, committed, assigned, and unassigned fund balance in the governmental fund financial statements, a flow assumption must be made about the order in which the resources are considered to be applied. It is the Board's policy to consider PEG restricted fund balance to have been depleted before using any of the components of unrestricted fund balance. Furthermore, when the components of unrestricted fund balance can be used for the same purpose, committed fund balance is depleted first, followed by assigned fund balance. Unassigned fund balance is applied last.

**Fund Balance Policies**

Fund balance of the General Fund is reported in various categories based on the nature of any limitations requiring the use of resources for specific purposes. The Board itself can establish limitations on the use of resources through either a commitment (committed fund balance) or an assignment (assigned fund balance).

The committed fund balance classification includes amounts that can be used only for the specific purposes determined by a formal action of the Board's highest level of decision-making authority. The board members are the highest level of decision-making authority for the Board that can, by passing a resolution prior to the end of the fiscal year, commit fund balance. Once passed, the limitation imposed by the resolution remains in place until a similar action is taken (the passing of another resolution) to remove or revise the limitation.

Amounts in the assigned fund balance classification are intended to be used by the government for specific purposes but do not meet the criteria to be classified as committed. The board members may also assign fund balance as they do when appropriating fund balance to cover a gap between estimated revenue and appropriations in the subsequent year's appropriated budget. Unlike commitments, assignments generally exist only temporarily. In other words, an additional action does not normally have to be taken for the removal of an assignment. Conversely, as discussed above, an additional action is essential to either remove or revise a commitment.

The Board has also adopted the following fund balance policies:

**Franchise Fees**

In any given year, the policy is to administratively grant back to the communities 95 percent of the previous year's audited franchise fee revenue in excess of board expenditures.

**PEG Fees**

The Board should carry a PEG fund balance equal to 0.75 times accumulated net depreciation of its capital assets, plus an amount equal to one-half of a three-year running average of PEG grants plus three months of Bloomfield Community Television and programming expense.

**Grants**

In addition to its two-channel (public and governmental) programming, the Board allocates PEG fees to the member communities (or their affiliated entities) or Birmingham Public School District upon a grant request. These grants are reported in the financial statements as operating grants. Unused franchise fees collected by the Board are returned to the Parties annually on a pro rata basis in accordance with the Board's franchise fee fund balance policy. The return of unused franchise fees is reported in the financial statements as administrative grants.

**Note 1 - Significant Accounting Policies (Continued)**

**Use of Estimates**

The preparation of financial statements in conformity with accounting principles generally accepted in the United States of America requires management to make estimates and assumptions that affect the reported amounts of assets and liabilities and disclosure of contingent assets and liabilities at the date of the financial statements and the reported amounts of revenue and expenses during the period. Actual results could differ from those estimates.

**Note 2 - Deposits and Investments**

Michigan Compiled Laws Section 129.91 (Public Act 20 of 1943, as amended) authorizes local governmental units to make deposits and invest in the accounts of federally insured banks, credit unions, and savings and loan associations that have offices in Michigan. The law also allows investments outside the state of Michigan when fully insured. The local unit is allowed to invest in bonds, securities, and other direct obligations of the United States or any agency or instrumentality of the United States; repurchase agreements; bankers' acceptances of United States banks; commercial paper rated within the two highest classifications that matures no more than 270 days after the date of purchase; obligations of the State of Michigan or its political subdivisions that are rated as investment grade; and mutual funds composed of investment vehicles that are legal for direct investment by local units of government in Michigan.

The Board has designated a broker-dealer and one credit union for the deposit of its funds. The investment policy adopted by the Board in accordance with Public Act 196 of 1997 has authorized investment in bonds and securities of the United States government and bank accounts and CDs but not the remainder of state statutory authority, as listed above. The Board's deposits and investments are in accordance with statutory authority.

The Board's cash and investments are subject to several types of risk, which are examined in more detail below:

***Custodial Credit Risk of Bank Deposits***

Custodial credit risk is the risk that, in the event of a credit union or counterparty failure, the Board's deposits may not be returned to it. The Board does have an investment policy that addresses custodial credit risk. At year end, the Board had no uninsured or uncollateralized deposits.

***Interest Rate Risk***

Interest rate risk is the risk that the value of investments will decrease as a result of a rise in interest rates. The Board's investment policy requires structuring the maturities of the portfolio to meet cash requirements, investing in short-term securities of investment pools, and purchasing securities with the intent to hold to maturity.

At year end, the Board had the following investments and maturities:

Investment	Fair Value	Less Than 1 Year	1-5 Years
Negotiable certificates of deposit	\$ 316,299	\$ 97,419	\$ 218,880
Federal Home Loan Bank bonds	468,035	-	468,035
U.S. Treasury securities	177,206	58,085	119,121

**June 30, 2022**

**Note 2 - Deposits and Investments (Continued)**

**Credit Risk**

State law limits investments in commercial paper to the top two ratings issued by nationally recognized statistical rating organizations. The Board's investment policy does not further limit its investment choices. As of June 30, 2022, the credit quality ratings of debt securities (other than the U.S. government) are as follows:

Investment	Carrying Value	Rating	Rating Organization
Negotiable certificates of deposit	\$ 316,299	N/A	Not rated
Federal Home Loan Bank bonds	468,035	AAA	Moody's

**Concentration of Credit Risk**

The Board's investment policy minimizes concentration of credit risk by placing a limit on the amount it may invest in any one issuer, the maximum being limited to available FDIC insurance. More than 5 percent of the Board's investments are in negotiable certificates of deposit; these investments are approximately 33 percent of the Board's total investments. While the Board does have certain issuers that are more than 5 percent of the Board's investments, no one issuer is over the FDIC insurance limit.

**Note 3 - Fair Value Measurements**

The Board categorizes its fair value measurements within the fair value hierarchy established by generally accepted accounting principles. The hierarchy is based on the valuation inputs used to measure the fair value of the assets. Level 1 inputs are quoted prices in active markets for identical assets, Level 2 inputs are significant other observable inputs, and Level 3 inputs are significant unobservable inputs. Investments that are measured at fair value using net asset value per share (or its equivalent) as a practical expedient are not classified in the fair value hierarchy.

In instances where inputs used to measure fair value fall into different levels in the fair value hierarchy, fair value measurements in their entirety are categorized based on the lowest level input that is significant to the valuation. The Board's assessment of the significance of particular inputs to these fair value measurements requires judgment and considers factors specific to each asset.

The Board has the following recurring fair value measurements as of June 30, 2022:

- Negotiable certificates of deposit, U.S. Treasury securities, and Federal Home Loan Bank bonds of \$316,299, \$177,206, and \$468,035, respectively, are valued using a matrix pricing model (Level 2 inputs).

The Board did not have any investments valued with Level 1 or 3 inputs at June 30, 2022.

**Note 4 - Amount on Deposit at the Village of Beverly Hills, Michigan**

Franchise fees and PEG fees collected by the Parties are remitted to the Village of Beverly Hills, Michigan. The Village of Beverly Hills, Michigan uses the franchise fees to pay for certain of the Board's monthly expenditures and periodically remits the balance to the Board.

**June 30, 2022**

**Note 5 - Capital Assets**

Capital asset activity of the Board's governmental activities was as follows:

	Balance July 1, 2021	Additions	Disposals and Adjustments	Balance June 30, 2022
Capital assets being depreciated:				
Equipment	\$ 175,973	\$ 38,024	\$ -	\$ 213,997
Production van	977,990	-	-	977,990
Subtotal	1,153,963	38,024	-	1,191,987
Accumulated depreciation:				
Equipment	129,547	6,429	-	135,976
Production van	845,536	19,007	-	864,543
Subtotal	975,083	25,436	-	1,000,519
Net capital assets	<u>\$ 178,880</u>	<u>\$ 12,588</u>	<u>\$ -</u>	<u>\$ 191,468</u>

**Note 6 - Risk Management**

The Board is exposed to various risks of loss related to property loss, torts, errors and omissions, and employee injuries (workers' compensation). The Board has purchased commercial insurance for claims relating to general liability and property. Settled claims relating to the commercial insurance have not exceeded the amount of insurance coverage in any of the past three fiscal years.

**Note 7 - Reconciliation of General Fund Column to the Statement of Net Position/Statement of Activities**

Net position reported in the statement of net position column is different than the fund balance reported in the General Fund column because of the different measurement focus and basis of accounting, as discussed in Note 1. Below is a reconciliation of the differences:

<b>Fund Balance Reported in General Fund</b>	\$ 1,409,086
Amounts reported for governmental activities in the statement of net position are different because:	
Capital assets used in governmental activities are not financial resources and are not reported in the General Fund	191,468
Receivables that are collected after year end, such that they are not available to pay bills outstanding as of year end, are not recognized in the General Fund	<u>177,354</u>
<b>Net Position of Governmental Activities</b>	<u>\$ 1,777,908</u>



**June 30, 2022**

**Note 7 - Reconciliation of General Fund Column to the Statement of Net Position/Statement of Activities (Continued)**

The change in net position reported in the statement of activities column is different than the change in fund balance reported in the General Fund column because of the different measurement focus and basis of accounting, as discussed in Note 1. Below is a reconciliation of the differences:

<b>Net Change in Fund Balance Reported in General Fund</b>	\$ (220,318)
Amounts reported for governmental activities in the statement of activities are different because:	
Governmental funds report capital outlays as expenditures; however, in the statement of activities, these costs are allocated over their estimated useful lives as depreciation:	
Capital outlay	38,024
Depreciation expense	(25,436)
Revenue is recorded in the statement of activities when earned; it is not reported in the General Fund until collected or collectible within 60 days of year end	<u>154,024</u>
<b>Change in Net Position of Governmental Activities</b>	<u><u>\$ (53,706)</u></u>

---

## Required Supplemental Information

---

## Birmingham Area Cable Board

### Required Supplemental Information Budgetary Comparison Schedule - General Fund

Year Ended June 30, 2022

	Original Budget	Amended Budget	Actual	Over (Under) Final Budget
<b>Revenue</b>				
Franchise fees:				
Birmingham, Michigan	\$ 157,225	\$ 157,225	\$ 157,857	\$ 632
Beverly Hills, Michigan	43,320	43,320	80,408	37,088
Franklin Village, Michigan	17,005	17,005	-	(17,005)
Bingham Farms, Michigan	7,600	7,600	21,031	13,431
PEG fees	396,125	396,125	261,914	(134,211)
Investment income (loss)	7,125	7,125	(43,253)	(50,378)
Total revenue	628,400	628,400	477,957	(150,443)
<b>Expenditures</b>				
PEG operations:				
Cable contractor	245,800	262,350	262,350	-
Communications expense	2,200	4,843	5,766	923
Grants	84,800	84,800	459	(84,341)
Production truck	10,000	10,000	590	(9,410)
Program expense	40,000	40,000	10,000	(30,000)
Equipment	20,000	35,000	40,103	5,103
Production crew uniforms	450	450	-	(450)
Board expenditures:				
Administrative grants	96,390	299,962	299,962	-
Conferences	900	900	679	(221)
Contract labor	1,500	1,500	763	(737)
Executive director	40,000	40,000	39,862	(138)
Liability insurance	3,000	3,000	2,795	(205)
Memberships	1,500	1,500	1,000	(500)
Operating expense	10,860	11,010	7,417	(3,593)
Professional fees	39,900	42,125	23,580	(18,545)
Advertising/Promotion	500	500	250	(250)
Municipal support services	30,600	30,600	2,699	(27,901)
Total expenditures	628,400	868,540	698,275	(170,265)
<b>Excess of Expenditures Over Revenue</b>	-	(240,140)	(220,318)	19,822
<b>Fund Balance - Beginning of year</b>	1,629,404	1,629,404	1,629,404	-
<b>Fund Balance - End of year</b>	<u>\$ 1,629,404</u>	<u>\$ 1,389,264</u>	<u>\$ 1,409,086</u>	<u>\$ 19,822</u>

See note to required supplemental information.

# Birmingham Area Cable Board

## Note to Required Supplemental Information

June 30, 2022

### ***Budgetary Information***

The annual budget is prepared by the executive director and adopted by the Board on a line-item basis; subsequent amendments are approved by the Board. The individual line items in the adopted budget are the legal level of budgetary control. Unexpended appropriations lapse at year end; encumbrances are not included as expenditures. The amount of encumbrances outstanding at June 30, 2022 has not been calculated.

The budget has been prepared in accordance with accounting principles generally accepted in the United States of America.

### ***Excess of Expenditures Over Appropriations in Budgeted Funds***

During the year, Birmingham Area Cable Board incurred expenditures that were in excess of the amounts budgeted as follows:

	<u>Budget</u>	<u>Actual</u>	<u>Variance</u>
Communications expense	\$ 4,843	\$ 5,766	\$ (923)
Equipment	35,000	40,103	(5,103)

The variances were due to additional costs for streaming channels and additional equipment purchase.



## **MEMORANDUM**

Finance Department

**DATE:** April 20, 2023  
**TO:** Thomas M. Markus, City Manager  
**FROM:** Mark Gerber, Finance Director/Treasurer  
**SUBJECT:** 3rd Quarter Investment Report

---

Public Act 213 of 2007 requires investment reporting on the City's general investments to be provided to the City Commission on a quarterly basis. This information is also required to be provided annually, which the City has and will continue to include within the audited financial statements.

General investments of the City are governed by State law and the City's General Investment Policy which is approved by the City Commission. The services of an outside investment advisor are utilized to assist the Treasurer in determining which types of investments are most appropriate and permitted under the investment policy, maximize the return on the City's investments within investment policy constraints and provide for cash flow needs.

The two primary objectives for investment of City funds are the preservation of principal and liquidity to protect against losses and provide sufficient funds to enable the City to meet all operating requirements that might be reasonably anticipated. Investment activities include all City funds except the retirement and retiree health-care funds as follows:

- General Fund
- Permanent Funds
- Special Revenue Funds
- Capital Projects Fund
- Enterprise Funds
- Debt Service Funds
- Component Unit Funds
- Internal Service Funds

Overall, the City has \$102.4 million invested in various securities according to its general investment policy as of March 31, 2023.

The City has two pooled funds (CLASS Pool and J-Fund), which are used to meet payroll, contractor and other accounts payable needs. As indicated on the attached schedule, there is approximately \$7.3 million invested in pooled funds at the end of quarter. A maximum of 50% of the portfolio may be invested in pooled funds that meet state guidelines. The amount currently invested in pooled funds is 7%.

The City also holds approximately \$51.9 million, or 51%, of its investments in treasury notes and bills, which are obligations of the United States. The maximum amount of investments that may be held in government securities is 100%.

Investments in federal agencies total approximately \$43.3 million, or 42%, of the City's investments. The maximum amount of the portfolio that may be invested in federal agencies is 75%.

The Investment Policy requires that the average maturity of the portfolio may not exceed two and one-half years. The current average maturity of the portfolio is 1.57 years.

**CITY OF BIRMINGHAM  
GENERAL INVESTMENT PORTFOLIO SUMMARY**

3/31/2023

YEAR	MATURITY DATE	DESCRIPTION	% YIELD	*	ISSUER	PAR VALUE	COST	CURRENT MARKET VALUE	YEARLY TOTAL	% OF TOTAL
2023	3/31/2023	CLASS POOL	4.852%	CITY	MICHIGAN CLASS	2,222,012.40	2,222,012.40	2,222,012.40		
	3/31/2023	J FUND	4.466%	CITY	COMERICA BANK	5,057,278.52	5,057,278.52	5,057,278.52		
	4/15/2023	TR NOTE	0.207%	INSIGHT	U.S.	3,000,000.00	3,001,992.34	2,995,680.00		
	5/15/2023	TR NOTE	1.578%	INSIGHT	U.S.	1,500,000.00	1,509,028.46	1,494,750.00		
	5/17/2023	AGENCY	0.360%	INSIGHT	FNMA	1,000,000.00	999,800.00	952,060.00		
	6/16/2023	AGENCY	0.500%	INSIGHT	FNMA	1,000,000.00	1,000,000.00	937,120.00		
	6/19/2023	AGENCY	1.851%	INSIGHT	FHLMC	1,500,000.00	1,550,467.50	1,493,325.00		
	6/26/2023	AGENCY	0.233%	INSIGHT	FHLMC	1,500,000.00	1,500,705.00	1,484,910.00		
	6/30/2023	AGENCY	0.390%	INSIGHT	FHLMC	1,500,000.00	1,499,025.00	1,401,135.00		
	8/15/2023	TR NOTE	4.130%	INSIGHT	U.S.	3,000,000.00	2,957,822.55	2,973,990.00		
	9/8/2023	AGENCY	1.466%	INSIGHT	FHLB	2,000,000.00	2,070,800.00	1,979,860.00		
	9/12/2023	AGENCY	1.591%	INSIGHT	FNMA	1,500,000.00	1,573,410.00	1,486,455.00		
	10/31/2023	TR NOTE	1.423%	INSIGHT	U.S.	1,500,000.00	1,587,954.24	1,484,415.00		
	10/31/2023	TR NOTE	0.307%	INSIGHT	U.S.	2,000,000.00	2,054,928.58	1,964,680.00		
	11/2/2023	AGENCY	0.320%	INSIGHT	FHLMC	1,500,000.00	1,500,000.00	1,459,785.00		
	11/15/2023	TR NOTE	1.572%	INSIGHT	U.S.	1,500,000.00	1,570,258.93	1,481,250.00		
	11/15/2023	TR NOTE	0.320%	INSIGHT	U.S.	2,000,000.00	1,997,037.95	1,945,160.00		
11/27/2023	AGENCY	0.202%	INSIGHT	FNMA	500,000.00	500,690.00	485,530.00			
								33,299,395.92	32.50%	
2024	1/19/2024	AGENCY	0.241%	INSIGHT	FFCB	1,000,000.00	999,670.00	964,190.00		
	2/5/2024	AGENCY	1.572%	INSIGHT	FNMA	1,500,000.00	1,558,201.50	1,471,230.00		
	2/29/2024	TR NOTE	1.637%	INSIGHT	U.S.	1,750,000.00	1,785,621.10	1,709,732.50		
	3/8/2024	AGENCY	4.396%	INSIGHT	FHLB	2,900,000.00	2,868,825.00	2,870,420.00		
	4/15/2024	TR NOTE	0.434%	INSIGHT	U.S.	3,000,000.00	2,995,546.88	2,871,570.00		
	5/31/2024	TR NOTE	0.462%	INSIGHT	U.S.	1,000,000.00	1,040,823.66	971,720.00		
	6/14/2024	AGENCY	0.377%	INSIGHT	FHLB	1,500,000.00	1,556,520.00	1,448,715.00		
	6/14/2024	AGENCY	4.343%	INSIGHT	FHLB	2,500,000.00	2,481,025.00	2,478,400.00		
	7/2/2024	AGENCY	1.719%	INSIGHT	FNMA	1,500,000.00	1,502,037.00	1,446,735.00		
	8/19/2024	AGENCY	0.450%	INSIGHT	FNMA	2,000,000.00	1,999,500.00	1,889,780.00		
	9/13/2024	AGENCY	1.729%	INSIGHT	FHLB	1,750,000.00	1,843,345.00	1,715,665.00		
	9/30/2024	TR NOTE	0.569%	INSIGHT	U.S.	1,500,000.00	1,541,020.65	1,438,650.00		
	10/31/2024	TR NOTE	0.465%	INSIGHT	U.S.	1,000,000.00	1,032,695.31	948,043.80		
	10/31/2024	TR NOTE	0.557%	INSIGHT	U.S.	2,000,000.00	2,057,741.08	1,924,816.20		
10/31/2024	TR NOTE	2.476%	INSIGHT	U.S.	1,000,000.00	994,378.35	968,670.00			
11/15/2024	TR NOTE	0.560%	INSIGHT	U.S.	1,500,000.00	1,578,637.84	1,452,360.00			
								26,570,697.50	25.94%	
2025	1/7/2025	AGENCY	0.362%	INSIGHT	FNMA	1,500,000.00	1,580,434.50	1,433,250.00		
	1/28/2025	AGENCY	0.550%	INSIGHT	FHLB	1,500,000.00	1,500,000.00	1,400,805.00		
	2/12/2025	AGENCY	0.344%	INSIGHT	FHLMC	1,500,000.00	1,575,136.50	1,427,160.00		
	2/26/2025	AGENCY	0.680%	INSIGHT	FHLB	1,000,000.00	1,000,000.00	933,000.00		
	2/28/2025	TR NOTE	0.508%	INSIGHT	U.S.	1,500,000.00	1,533,925.38	1,417,620.00		
	3/28/2025	AGENCY	1.250%	INSIGHT	FHLB	1,500,000.00	1,370,835.00	1,395,525.00		
	3/28/2025	AGENCY	0.450%	INSIGHT	FHLMC	1,500,000.00	1,500,000.00	1,391,280.00		
	3/31/2025	TR NOTE	0.669%	INSIGHT	U.S.	1,500,000.00	1,491,215.96	1,398,405.00		
	6/30/2025	AGENCY	0.750%	INSIGHT	FHLB	2,000,000.00	2,000,000.00	1,855,180.00		
	7/15/2025	TR NOTE	4.233%	INSIGHT	U.S.	3,000,000.00	2,903,095.99	2,933,790.00		
	8/15/2025	TR NOTE	3.037%	INSIGHT	U.S.	2,000,000.00	1,937,506.70	1,911,800.00		
	9/15/2025	TR NOTE	4.187%	INSIGHT	U.S.	3,000,000.00	2,942,939.74	2,969,310.00		
	10/15/2025	TR NOTE	4.457%	INSIGHT	U.S.	1,500,000.00	1,491,386.71	1,510,605.00		
10/31/2025	TR NOTE	3.167%	INSIGHT	U.S.	2,500,000.00	2,487,020.09	2,443,350.00			
11/15/2025	TR NOTE	3.025%	INSIGHT	U.S.	2,000,000.00	1,951,959.82	1,917,120.00			
								26,338,200.00	25.71%	
2026	2/25/2026	AGENCY	3.577%	INSIGHT	FFCB	1,500,000.00	1,487,659.50	1,469,865.00		
	3/31/2026	TR NOTE	4.144%	INSIGHT	U.S.	3,000,000.00	2,816,142.86	2,866,980.00		
	6/16/2026	AGENCY	4.203%	INSIGHT	FFCB	3,000,000.00	2,928,240.00	2,953,470.00		
	7/27/2026	AGENCY	4.412%	INSIGHT	FFCB	1,500,000.00	1,504,590.00	1,522,320.00		
								8,812,635.00	8.60%	
2027	3/31/2027	TR NOTE	4.071%	INSIGHT	U.S.	1,500,000.00	1,406,430.81	1,431,330.00		
	6/30/2027	TR NOTE	3.701%	INSIGHT	U.S.	3,000,000.00	2,943,867.19	2,945,400.00		
	9/30/2027	TR NOTE	4.005%	INSIGHT	U.S.	1,500,000.00	1,507,851.56	1,526,715.00		
	12/1/2027	AGENCY	3.803%	INSIGHT	U.S.	1,500,000.00	1,520,295.00	1,522,590.00		
								7,426,035.00	7.25%	
			2.209%			105,179,290.92	105,369,333.15	102,446,963.42	102,446,963.42	100.00%

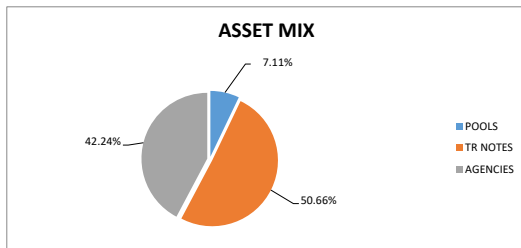

POOLS	\$7,279,290.92	7.11%
TR NOTES	\$51,897,912.50	50.66%
AGENCIES	\$43,269,760.00	42.24%
<b>TOTAL</b>	<b>\$102,446,963.42</b>	<b>100.00%</b>

COMPARATIVE RETURNS			
	City Portfolio	1-Yr TR	2-Yr TR
Current Month	2.21%	3.73%	3.70%
Previous Month	2.33%	3.45%	3.50%
1 Year Ago	0.82%	0.32%	0.59%

AVERAGE MATURITY (YEARS):

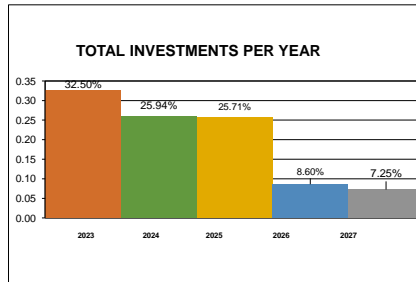

* INSIGHT:	\$95,167,672.50	92.89%
* ASSIGNED TO CITY:	\$7,279,290.92	7.11%
	\$102,446,963.42	100.00%

copies:  
 Treasury  
 Finance Director/Treasurer  
 Finance  
 Audit  
 Deputy Treasurer  
 Cutwater Asset Management



## **MEMORANDUM**

Finance Department

**DATE:** April 28, 2023

**TO:** Thomas M. Markus, City Manager

**FROM:** Mark Gerber, Director of Finance/Treasurer

**SUBJECT:** Third Quarter Financial Reports

---

### **Background**

Chapter 7, section 3(b) of the City charter requires the Director of Finance to report on the condition of the City quarterly. Quarterly reports are prepared for the first 3 quarters of the year with the annual audit serving as the 4<sup>th</sup> quarter report. Only the following funds are reported quarterly because by State law they require a budget: General Fund, Greenwood Cemetery Perpetual Care Fund, Major and Local Street Funds, Solid Waste Fund, Community Development Block Grant Fund, Law and Drug Enforcement Fund, Michigan Indigent Defense Commission Fund, Opioid Settlement Fund, Baldwin Public Library Fund, Principal Shopping District Fund, Brownfield Redevelopment Authority Fund, Triangle District Corridor Improvement Authority Fund, and the Debt Service Fund.

### **Overview**

Attached is the third quarter 2022-2023 fiscal year financial reports. The reports compare budget to actual for the current fiscal year and the prior fiscal year for the same quarter. The previous year's budget and actual have been restated using the required state chart of account groupings. This allows meaningful comparisons between fiscal years as well as percentage of budget received/spent for the year. The budget categories used for each fund are the same ones approved by the Commission when they adopted the 2022-2023 budget. Budget discussions that follow will focus on each fund individually.

At this point, 75% of the fiscal year has lapsed.

### **General Fund**

Revenues are approximately \$5.6M higher than the previous year as a result of an increase in tax revenue of approximately \$2.1M, an increase in licenses and permits of \$2.1M, and an increase in interest and rent of \$.4M, an increase in charges for services of \$.3M, and an increase in special assessments of \$.3M. Taxes increased as a result of an increase in taxable value. Licenses and



Permits increased as a result of an increase in construction activity, especially some large scale projects. Interest and Rent increased as a result of higher interest rates. Charges for services has increased as a result of higher ice arena revenues. Special assessments increased as a result of sidewalk assessments from downtown projects.

State and Local grant funds and Fines and Forfeitures are below expected budget due to timing of when the revenues are received. Special Assessments are at 39% due to timing of when these are billed. Licenses and Permits are at 144% due to large construction projects this fiscal year. Fines and Forfeitures are at 54% due to a timing difference in receiving court revenues. Federal grants are at 778% due to FEMA grant activity.

Total current year-to-date expenditures for the General Fund are higher than the prior year by approximately \$3.4M. The increase is due to sidewalk improvements made on S. Old Woodward. Judicial is at 103% of budget as a result of a higher allocation of court expenditures to the City. This budgetary center will need to be adjusted during the 4<sup>th</sup> quarter budget amendment. All other functional expenditures are comparable to the previous year both in dollar amount and percentage of budget spent.

#### **Greenwood Cemetery Fund**

Cemetery perpetual care revenues are approximately \$20,000 higher than the previous year mostly due to higher plot sales than the previous year. No expenditures have been budgeted for this fiscal year.

#### **Major Street Fund**

Total revenues are approximately \$1,800,000 less than the prior year as a result of lower budgeted transfers from the General Fund. State grant revenue is at 61% as a result of February and March road funding being received until after the quarter ended.

Overall expenditures are \$1,200,000 higher than the previous year as a result of higher road construction expenditures through the end of the quarter compared to the prior year.

#### **Local Street Fund**

Total revenues for the year are approximately \$200,000 higher than the prior fiscal year mostly due to higher scheduled transfers from the General Fund. We anticipate 2 large road special assessments which will be billed after those roads have been cape sealed (likely in the spring). As with the Major Street fund, state grants are generally received 2 months after the close of the month which explains the low budget to actual variance.

Total expenditures are approximately the same as the prior year. Two large local street projects will start in the 4<sup>th</sup> quarter.

#### **Solid Waste Fund**

Revenues are approximately \$82,000 higher than the previous year as a result of higher property tax revenue and interest income.

Expenditures are approximately the same as the prior fiscal year.

#### **Brownfield Redevelopment Authority Fund**

Revenues are approximately \$330,000 more than the prior year. This is the result of higher property tax revenue as a result of more property value subject to tax capture.

The increase in expenditures are due to increased reimbursements to developers as a result of higher tax revenue capture. Expenditures are at 73% of budget due to the winter tax distribution to the developers not occurring until after the quarter end.

### **Principal Shopping District**

Revenues are up slightly from the prior year due to an increase in special assessment revenue. The special assessment rate was increased for this fiscal year. Special assessments were billed in January.

Expenditures for the year are slightly down from the prior year due to vacancy of the department head position for a portion of the fiscal year.

### **Community Development Block Grant Fund**

Revenues and expenditures are approximately in line with the previous fiscal year. The City Commission just approved the grant contract with NEXT for this program year, so expenditures should increase in the 4<sup>th</sup> quarter.

### **Triangle District Corridor Improvement Authority**

The City is attempting to re-engage with the County regarding tax capture for the district. To-date no property taxes have been captured and no funds spent on this activity.

### **Michigan Indigent Defense Fund**

This fund records the revenues and expenditures of providing legal defense to indigent defendants at the 48<sup>th</sup> District Court. The legal costs are funded mainly through a grant from the State of Michigan. The City of Birmingham assumed control of this fund from the 48<sup>th</sup> District Court on January 1, 2022, so there is only activity from January to March in the previous fiscal year.

### **Baldwin Library**

Revenue has increased approximately \$180,000. This is primarily the result of an increase in property tax revenue.

Expenditures are approximately \$400,000 more than the prior fiscal year primarily due to building design services for the next phase of building improvements, and increase in online database services, and personnel costs.

### **Law and Drug Enforcement Fund**

Revenues are approximately the same as the prior year. Revenues are the result of forfeited property proceeds from prosecutions of drug cases.

### **Debt Service Fund**

Budgeted revenues and expenditures are based on scheduled debt service payments. Expenditures are at 100% spent for the year as a result of making all of the debt payments for the fiscal year.

CITY OF BIRMINGHAM  
 QUARTERLY BUDGET REPORT  
 GENERAL FUND  
 QUARTER ENDED: MARCH 31, 2023 AND MARCH 31, 2022  
 % OF FISCAL YEAR COMPLETED: 75%

	2022-2023			2021-2022		
	AMENDED BUDGET	YEAR-TO-DATE ACTUAL	% OF BUDGET USED	AMENDED BUDGET	YEAR-TO-DATE ACTUAL	% OF BUDGET USED
<b>REVENUES:</b>						
TAXES	30,327,140	30,350,341	100%	28,293,010	28,283,081	100%
SPECIAL ASSESSMENTS	1,265,360	498,161	39%	575,420	154,315	27%
LICENSES AND PERMITS	2,678,930	3,866,953	144%	2,708,260	1,736,588	64%
FEDERAL GRANTS	51,500	400,556	778%	941,900	286,843	30%
STATE GRANTS	2,446,470	1,473,344	60%	2,664,910	1,299,552	49%
LOCAL CONTRIBUTIONS	90,240	45,148	50%	286,300	45,127	16%
CHARGES FOR SERVICES	3,159,460	2,560,877	81%	3,106,030	2,276,737	73%
FINES AND FORFEITURES	1,372,250	741,950	54%	1,085,250	671,708	62%
INTEREST AND RENT	417,320	622,934	149%	(601,940)	240,234	-40%
OTHER REVENUE	51,650	83,406	161%	51,150	86,872	170%
TRANSFERS IN	100,000	75,000	75%	100,000	75,000	75%
<b>TOTAL REVENUES</b>	<b>41,960,320</b>	<b>40,718,670</b>	<b>97%</b>	<b>39,210,290</b>	<b>35,156,057</b>	<b>90%</b>
<b>EXPENDITURES:</b>						
GENERAL GOVERNMENT	5,657,570	3,639,302	64%	6,093,911	3,721,994	61%
JUDICIAL	1,243,770	1,282,461	103%	1,357,820	1,018,316	75%
PUBLIC SAFETY	18,779,602	13,350,872	71%	18,321,399	12,804,182	70%
PUBLIC WORKS	10,979,849	6,132,704	56%	4,739,620	2,095,493	44%
HEALTH AND WELFARE	179,040	128,158	72%	-	-	0%
COMMUNITY DEVELOPMENT	764,854	382,950	50%	751,801	413,444	55%
RECREATION AND CULTURE	3,226,608	1,931,820	60%	2,819,171	1,658,847	59%
TRANSFERS OUT	3,835,968	2,898,468	76%	6,190,000	4,642,500	75%
<b>TOTAL EXPENDITURES</b>	<b>44,667,261</b>	<b>29,746,735</b>	<b>67%</b>	<b>40,273,722</b>	<b>26,354,776</b>	<b>65%</b>
<b>CONTRIBUTION TO (USE OF) FUND BALANCE</b>	<b>(2,706,941)</b>	<b>10,971,935</b>		<b>(1,063,432)</b>	<b>8,801,281</b>	

CITY OF BIRMINGHAM  
 QUARTERLY BUDGET REPORT  
 GREENWOOD CEMETERY FUND  
 QUARTER ENDED: MARCH 31, 2023 AND MARCH 31, 2022  
 % OF FISCAL YEAR COMPLETED: 75%

	2022-2023			2021-2022		
	AMENDED BUDGET	YEAR-TO-DATE ACTUAL	% OF BUDGET USED	AMENDED BUDGET	YEAR-TO-DATE ACTUAL	% OF BUDGET USED
REVENUES:						
CHARGES FOR SERVICES	60,000	48,900	82%	60,000	31,846	53%
INTEREST AND RENT	<u>22,500</u>	<u>21,987</u>	98%	<u>24,500</u>	<u>18,577</u>	76%
TOTAL REVENUES	<u>82,500</u>	<u>70,887</u>	86%	<u>84,500</u>	<u>50,423</u>	60%
EXPENDITURES:						
ENGINEERING AND PUBLIC SERVICES	<u>-</u>	<u>-</u>	0%	<u>-</u>	<u>-</u>	0%
TOTAL EXPENDITURES	<u>-</u>	<u>-</u>		<u>-</u>	<u>-</u>	

CITY OF BIRMINGHAM  
 QUARTERLY BUDGET REPORT  
 MAJOR STREETS  
 QUARTER ENDED: MARCH 31, 2023 AND MARCH 31, 2022  
 % OF FISCAL YEAR COMPLETED: 75%

	2022-2023			2021-2022		
	AMENDED BUDGET	YEAR-TO-DATE ACTUAL	% OF BUDGET USED	AMENDED BUDGET	YEAR-TO-DATE ACTUAL	% OF BUDGET USED
<b>REVENUES:</b>						
SPECIAL ASSESSMENT	31,900	-	0%	-	450	
STATE GRANTS	1,786,350	1,085,311	61%	1,794,280	1,034,228	58%
INTEREST AND RENT	38,590	75,815	196%	(160,420)	27,039	-17%
OTHER REVENUE	-	27,129	0%	-	1,245	0%
TRANSFERS IN	<u>1,500,000</u>	<u>1,125,000</u>	75%	<u>4,100,000</u>	<u>3,075,000</u>	75%
<b>TOTAL REVENUES</b>	<u>3,356,840</u>	<u>2,313,255</u>	69%	<u>5,733,860</u>	<u>4,137,961</u>	72%
<b>EXPENDITURES:</b>						
<b>PUBLIC WORKS:</b>						
ADMINISTRATIVE	19,640	15,433	79%	20,570	15,852	77%
TRAFFIC CONTROLS & ENGINEERING	993,067	187,157	19%	579,755	176,359	30%
CONSTRUCTION OF ROADS & BRIDGES	4,098,064	2,462,875	60%	4,834,022	1,139,934	24%
MAINTENANCE OF ROADS & BRIDGES	447,520	174,429	39%	595,840	320,140	54%
STREET CLEANING	237,990	130,898	55%	236,770	138,436	58%
STREET TREES	456,420	281,811	62%	352,680	240,641	68%
SNOW AND ICE REMOVAL	<u>274,550</u>	<u>90,648</u>	33%	<u>216,770</u>	<u>100,368</u>	46%
<b>TOTAL EXPENDITURES</b>	<u>6,527,251</u>	<u>3,343,252</u>	51%	<u>6,836,407</u>	<u>2,131,730</u>	31%
<b>CONTRIBUTION TO (USE OF) FUND BALANCE</b>	<u>(3,170,411)</u>	<u>(1,029,997)</u>		<u>(1,102,547)</u>	<u>2,006,232</u>	

CITY OF BIRMINGHAM  
 QUARTERLY BUDGET REPORT  
 LOCAL STREETS  
 QUARTER ENDED: MARCH 31, 2023 AND MARCH 31, 2022  
 % OF FISCAL YEAR COMPLETED: 75%

	2022-2023			2021-2022		
	AMENDED BUDGET	YEAR-TO-DATE ACTUAL	% OF BUDGET USED	AMENDED BUDGET	YEAR-TO-DATE ACTUAL	% OF BUDGET USED
<b>REVENUES:</b>						
SPECIAL ASSESSMENT	521,730	92,339	18%	174,730	131,594	75%
STATE GRANTS	729,630	436,288	60%	683,860	417,724	61%
INTEREST AND RENT	28,950	41,351	143%	(119,400)	16,877	-14%
OTHER REVENUE	5,000	18,398	368%	5,000	12,511	250%
TRANSFERS IN	<u>2,250,000</u>	<u>1,687,500</u>	75%	<u>1,950,000</u>	<u>1,462,500</u>	75%
<b>TOTAL REVENUES</b>	<u>3,535,310</u>	<u>2,275,876</u>	64%	<u>2,694,190</u>	<u>2,041,207</u>	76%
<b>EXPENDITURES:</b>						
<b>PUBLIC WORKS:</b>						
ADMINISTRATIVE	27,680	21,375	77%	28,960	22,167	77%
TRAFFIC CONTROLS & ENGINEERING	66,100	40,631	61%	68,700	49,732	72%
CONSTRUCTION OF ROADS & BRIDGES	1,626,892	461,324	28%	1,989,241	586,415	29%
MAINTENANCE OF ROADS & BRIDGES	1,073,210	335,976	31%	589,333	289,566	49%
STREET CLEANING	258,350	110,555	43%	255,550	141,988	56%
STREET TREES	946,370	666,731	70%	739,630	572,193	77%
SNOW AND ICE REMOVAL	<u>175,490</u>	<u>89,177</u>	51%	<u>173,780</u>	<u>80,676</u>	46%
<b>TOTAL EXPENDITURES</b>	<u>4,174,092</u>	<u>1,725,769</u>	41%	<u>3,845,194</u>	<u>1,742,737</u>	45%
<b>CONTRIBUTION TO (USE OF) FUND BALANCE</b>	<u>(638,782)</u>	<u>550,107</u>		<u>(1,151,004)</u>	<u>298,470</u>	

CITY OF BIRMINGHAM  
 QUARTERLY BUDGET REPORT  
 SOLID WASTE  
 QUARTER ENDED: MARCH 31, 2023 AND MARCH 31, 2022  
 % OF FISCAL YEAR COMPLETED: 75%

	2022-2023			2021-2022		
	AMENDED BUDGET	YEAR-TO-DATE ACTUAL	% OF BUDGET USED	AMENDED BUDGET	YEAR-TO-DATE ACTUAL	% OF BUDGET USED
REVENUES:						
TAXES	2,245,000	2,248,764	100%	2,175,000	2,179,167	100%
STATE GRANTS	3,990	4,180	0%	3,990	4,063	0%
CHARGES FOR SERVICES	17,100	11,770	69%	17,100	13,062	76%
INTEREST AND RENT	15,440	24,072	156%	(40,000)	8,744	-22%
OTHER REVENUE	-	208	0%	-	1,500	0%
TOTAL REVENUES	<u>2,281,530</u>	<u>2,288,994</u>	100%	<u>2,156,090</u>	<u>2,206,537</u>	102%
EXPENDITURES:						
PUBLIC WORKS	<u>2,274,210</u>	<u>1,645,626</u>	72%	<u>2,119,200</u>	<u>1,563,122</u>	74%
CONTRIBUTION TO (USE OF) FUND BALANCE	<u>7,320</u>	<u>643,368</u>		<u>36,890</u>	<u>643,415</u>	

CITY OF BIRMINGHAM  
 QUARTERLY BUDGET REPORT  
 PRINCIPAL SHOPPING DISTRICT  
 QUARTER ENDED: MARCH 31, 2023 AND MARCH 31, 2022  
 % OF FISCAL YEAR COMPLETED: 75%

	2022-2023			2021-2022		
	AMENDED BUDGET	YEAR-TO-DATE ACTUAL	% OF BUDGET USED	AMENDED BUDGET	YEAR-TO-DATE ACTUAL	% OF BUDGET USED
REVENUES:						
SPECIAL ASSESSMENTS	1,101,370	1,063,654	97%	1,054,970	959,974	91%
CHARGES FOR SERVICES	25,000	-	0%	25,000	-	0%
INTEREST AND RENT	5,310	10,723	202%	(19,300)	3,615	-19%
OTHER REVENUE	<u>160,000</u>	<u>185,426</u>	116%	<u>100,000</u>	<u>163,896</u>	164%
TOTAL REVENUES	<u>1,291,680</u>	<u>1,259,803</u>	98%	<u>1,160,670</u>	<u>1,127,485</u>	97%
EXPENDITURES						
COMMUNITY DEVELOPMENT	<u>1,464,815</u>	<u>757,058</u>	52%	<u>1,235,230</u>	<u>901,532</u>	73%
CONTRIBUTION TO (USE OF) FUND BALANCE	<u>(173,135)</u>	<u>502,745</u>		<u>(74,560)</u>	<u>225,954</u>	



CITY OF BIRMINGHAM  
 QUARTERLY BUDGET REPORT  
 BROWNFIELD REDEVELOPMENT FUND  
 QUARTER ENDED: MARCH 31, 2023 AND MARCH 31, 2022  
 % OF FISCAL YEAR COMPLETED: 75%

	2022-2023			2021-2022		
	AMENDED BUDGET	YEAR-TO-DATE ACTUAL	% OF BUDGET USED	AMENDED BUDGET	YEAR-TO-DATE ACTUAL	% OF BUDGET USED
REVENUES:						
TAXES	627,240	691,568	110%	428,000	369,787	86%
CHARGES FOR SERVICES	-	-	0%	-	-	0%
INTEREST AND RENT	770	2,034	264%	(3,000)	643	-21%
OTHER REVENUE	20,000	5,394	27%	20,000	351	2%
TRANSFERS IN	-	-	0%	-	-	0%
TOTAL REVENUES	<u>648,010</u>	<u>698,996</u>	108%	<u>445,000</u>	<u>370,781</u>	83%
EXPENDITURES						
COMMUNITY DEVELOPMENT	<u>647,240</u>	<u>471,787</u>	73%	<u>448,000</u>	<u>301,147</u>	67%
CONTRIBUTION TO (USE OF) FUND BALANCE	<u>770</u>	<u>227,208</u>		<u>(3,000)</u>	<u>69,634</u>	

CITY OF BIRMINGHAM  
 QUARTERLY BUDGET REPORT  
 TRIANGLE DISTRICT CORRIDOR IMPROVEMENT AUTHORITY  
 QUARTER ENDED: MARCH 31, 2023 AND MARCH 31, 2022  
 % OF FISCAL YEAR COMPLETED: 75%

	2022-2023			2021-2022		
	AMENDED BUDGET	YEAR-TO-DATE ACTUAL	% OF BUDGET USED	AMENDED BUDGET	YEAR-TO-DATE ACTUAL	% OF BUDGET USED
REVENUES:						
PROPERTY TAXES	-	-	0%	-	-	0%
INTEREST AND RENT	<u>190</u>	<u>254</u>	134%	<u>470</u>	<u>98</u>	21%
TOTAL REVENUES	<u>190</u>	<u>254</u>	134%	<u>470</u>	<u>98</u>	21%
EXPENDITURES						
COMMUNITY DEVELOPMENT	<u>-</u>	<u>-</u>	0%	<u>-</u>	<u>-</u>	0%
CONTRIBUTION TO (USE OF) FUND BALANCE	<u>190</u>	<u>254</u>		<u>470</u>	<u>98</u>	

CITY OF BIRMINGHAM  
 QUARTERLY BUDGET REPORT  
 MICHIGAN INDIGENT DEFENSE FUND  
 QUARTER ENDED: MARCH 31, 2023 AND MARCH 31, 2022  
 % OF FISCAL YEAR COMPLETED: 75%

	2022-2023			2021-2022		
	AMENDED BUDGET	YEAR-TO-DATE ACTUAL	% OF BUDGET USED	AMENDED BUDGET	YEAR-TO-DATE ACTUAL	% OF BUDGET USED
REVENUES:						
STATE GRANTS	493,960	207,016	42%	515,257	167,159	32%
LOCAL CONTRIBUTIONS	17,600	-	0%	17,293	-	0%
INTEREST AND RENT	<u>480</u>	<u>3,037</u>	633%	<u>-</u>	<u>515</u>	#DIV/0!
TOTAL REVENUES	<u>512,040</u>	<u>210,053</u>	41%	<u>532,550</u>	<u>167,674</u>	31%
EXPENDITURES						
HEALTH AND WELFARE	<u>514,900</u>	<u>237,788</u>	46%	<u>532,550</u>	<u>59,860</u>	11%
CONTRIBUTION TO (USE OF) FUND BALANCE	<u>(2,860)</u>	<u>(27,736)</u>		<u>-</u>	<u>107,814</u>	

CITY OF BIRMINGHAM  
 QUARTERLY BUDGET REPORT  
 LAW & DRUG ENFORCEMENT FUND  
 QUARTER ENDED: MARCH 31, 2023 AND MARCH 31, 2022  
 % OF FISCAL YEAR COMPLETED: 75%

	2022-2023			2021-2022		
	AMENDED BUDGET	YEAR-TO-DATE ACTUAL	% OF BUDGET USED	AMENDED BUDGET	YEAR-TO-DATE ACTUAL	% OF BUDGET USED
REVENUES:						
FINES & FORFEITURES	25,000	42,410	170%	25,000	37,844	151%
INTEREST AND RENT	580	2,487	429%	2,000	703	35%
OTHER REVENUE	-	-	0%	-	3,851	0%
TOTAL REVENUES	<u>25,580</u>	<u>44,897</u>	176%	<u>27,000</u>	<u>42,398</u>	157%
EXPENDITURES:						
PUBLIC SAFETY	5,430	3,635	67%	119,590	-	0%
CAPITAL OUTLAY	-	-	0%	-	-	0%
TOTAL EXPENDITURES	<u>5,430</u>	<u>3,635</u>	67%	<u>119,590</u>	<u>-</u>	0%
CONTRIBUTION TO (USE OF) FUND BALANCE	<u>20,150</u>	<u>41,262</u>		<u>(92,590)</u>	<u>42,398</u>	

CITY OF BIRMINGHAM  
 QUARTERLY BUDGET REPORT  
 BALDWIN LIBRARY  
 QUARTER ENDED: MARCH 31, 2023 AND MARCH 31, 2022  
 % OF FISCAL YEAR COMPLETED: 75%

	2022-2023			2021-2022		
	AMENDED BUDGET	YEAR-TO-DATE ACTUAL	% OF BUDGET USED	AMENDED BUDGET	YEAR-TO-DATE ACTUAL	% OF BUDGET USED
REVENUES:						
TAXES	3,854,880	3,867,794	100%	3,663,280	3,676,830	100%
FEDERAL GRANTS	-	6,400	0%	-	-	0%
STATE GRANTS	36,000	26,175	73%	35,000	7,058	20%
LOCAL CONTRIBUTIONS	1,062,390	644,701	61%	1,030,710	723,595	70%
CHARGES FOR SERVICES	21,000	23,667	113%	18,400	19,145	104%
FINES AND FORFEITURES	6,000	3,265	54%	3,000	3,957	132%
INTEREST AND RENT	30,000	52,315	174%	30,000	16,943	56%
TOTAL REVENUES	<u>5,010,270</u>	<u>4,624,317</u>	92%	<u>4,780,390</u>	<u>4,447,528</u>	93%
EXPENDITURES:						
RECREATION AND CULTURE	<u>4,531,340</u>	<u>3,189,353</u>	70%	<u>4,208,760</u>	<u>2,783,327</u>	66%
CONTRIBUTION TO (USE OF) FUND BALANCE	<u>478,930</u>	<u>1,434,964</u>		<u>571,630</u>	<u>1,664,201</u>	

CITY OF BIRMINGHAM  
 QUARTERLY BUDGET REPORT  
 OPIOID SETTLEMENT  
 QUARTER ENDED: MARCH 31, 2023 AND MARCH 31, 2022  
 % OF FISCAL YEAR COMPLETED: 75%

	2022-2023			2021-2022		
	AMENDED BUDGET	YEAR-TO-DATE ACTUAL	% OF BUDGET USED	AMENDED BUDGET	YEAR-TO-DATE ACTUAL	% OF BUDGET USED
REVENUES:						
INTEREST AND RENT	-	-	0%	-	-	0%
OTHER REVENUE	-	35,598	0%	-	-	0%
TOTAL REVENUES	-	35,598		-	-	
EXPENDITURES						
HEALTH AND WELFARE	-	-	0%	-	-	0%
CONTRIBUTION TO (USE OF) FUND BALANCE	-	35,598		-	-	

CITY OF BIRMINGHAM  
 QUARTERLY BUDGET REPORT  
 COMMUNITY DEVELOPMENT BLOCK GRANT  
 QUARTER ENDED: MARCH 31, 2023 AND MARCH 31, 2022  
 % OF FISCAL YEAR COMPLETED: 75%

	2022-2023			2021-2022		
	AMENDED BUDGET	YEAR-TO-DATE ACTUAL	% OF BUDGET USED	AMENDED BUDGET	YEAR-TO-DATE ACTUAL	% OF BUDGET USED
REVENUES:						
FEDERAL GRANTS	<u>36,670</u>	<u>5,666</u>	15%	<u>36,100</u>	<u>4,311</u>	12%
EXPENDITURES						
HEALTH AND WELFARE	<u>36,670</u>	<u>5,666</u>	15%	<u>36,100</u>	<u>4,311</u>	12%
CONTRIBUTION TO (USE OF) FUND BALANCE	<u><u>-</u></u>	<u><u>-</u></u>		<u><u>-</u></u>	<u><u>-</u></u>	

CITY OF BIRMINGHAM  
 QUARTERLY BUDGET REPORT  
 DEBT SERVICE FUND  
 QUARTER ENDED: MARCH 31, 2023 AND MARCH 31, 2022  
 % OF FISCAL YEAR COMPLETED: 75%

	2022-2023			2021-2022		
	AMENDED BUDGET	YEAR-TO-DATE ACTUAL	% OF BUDGET USED	AMENDED BUDGET	YEAR-TO-DATE ACTUAL	% OF BUDGET USED
REVENUES:						
TAXES	1,508,190	1,513,248	100%	1,566,100	1,565,468	100%
STATE GRANTS	5,200	2,982	57%	3,300	5,249	159%
INTEREST AND RENT	<u>1,740</u>	<u>3,172</u>	182%	<u>(5,000)</u>	<u>1,591</u>	-32%
TOTAL REVENUES	<u>1,515,130</u>	<u>1,519,402</u>	100%	<u>1,564,400</u>	<u>1,572,308</u>	101%
EXPENDITURES:						
DEBT SERVICE	<u>1,515,130</u>	<u>1,514,623</u>	100%	<u>1,566,900</u>	<u>1,566,386</u>	100%
CONTRIBUTION TO (USE OF) FUND BALANCE	<u>-</u>	<u>4,779</u>		<u>(2,500)</u>	<u>5,922</u>	





## **MEMORANDUM**

Finance Department

**DATE:** April 25, 2023

**TO:** Thomas M. Markus, City Manager

**FROM:** Mark Gerber, Director of Finance/Treasurer

**SUBJECT:** Recent Amendments to PA 33 - Police and Fire Protection Act

---

### **Background**

In December of 2022, the Governor signed an amendment to Public Act 33, known as the Police and Fire Protection Act. The public Act allows a municipality to levy a special assessment to every property in its jurisdiction for public safety costs. The amendment changes which municipalities are qualified to levy special assessments as a funding source for public safety expenditures.

Under this Act, a city with a population of over 15,500 may use a special assessment to fund public safety related costs if the question of raising money by special assessment and the amount to be levied under the special assessment are approved by a majority of the electors. Like any other special assessment, there is a public hearing process to identify the special assessment area and amount to assess. Unlike other special assessments which are allocated based on a proportion of benefit received, like property frontage for instance, this special assessment is allocated based on taxable value of the property.

### **Analysis**

According to the Act, it appears that the funding generated from this Act is restricted for use to, motor vehicles, apparatus, equipment, and housing for police and fire. It cannot be used to replace the operating costs of the police and fire departments.

At this time, given our fund balances and millage capacity (difference between the Headlee maximum and what we are currently levying), I do not see that the City needs to adopt this strategy in the near future in order to provide relief from Headlee. One item of possible benefit from this legislation is if we need to replace several large pieces of fire equipment in a limited period of time. The cost of new fire equipment has increased sharply in price due to limited supply of parts and vendor capacity issues. This strategy could be employed to generate funds quickly and could be an alternative to bonding. In either case, whether utilizing this Act or special assessments, or bonding as a source of revenue for public safety expenditures, the funding choice

must be approved by the electors. The maximum that can be specially assessed is 10 mills per year. One mill is approximately \$3 million dollars based on our current taxable value.

**POLICE AND FIRE PROTECTION (EXCERPT)**  
**Act 33 of 1951**

**41.801 Purchase of police and fire motor vehicles, apparatus, equipment, and housing; appropriation; special assessment; bonds; election; estimate of cost and expenses; special assessment district; hearing; publication or posting of notice; distribution of special assessment levy; transfer or loan of money from general fund; repayment; exercise of powers; assessment after December 31, 2018; “taxable value” defined; finding of invalid assessment; bonds subject to revised municipal finance act.**

Sec. 1. (1) The township board of a township, or the township boards of adjoining townships acting jointly, whether or not the townships are located in the same county, may purchase police and fire motor vehicles, apparatus, equipment, and housing and for that purpose may provide by resolution for the appropriation of general or contingent funds. Before January 1, 1999, the appropriation for fire motor vehicles, apparatus, equipment, and housing in a 1-year period must not exceed 10 mills of the assessed valuation of the area in their respective townships for which fire protection is to be furnished. After December 31, 1998, the appropriation for fire motor vehicles, apparatus, equipment, and housing in a 1-year period must not exceed 10 mills of the taxable value of the area in their respective townships for which fire protection is to be furnished. Before January 1, 1999, the appropriation for police motor vehicles, apparatus, equipment, and housing in a 1-year period must not exceed 10 mills of the assessed valuation of the area in their respective townships for which police protection is to be furnished. After December 31, 1998, the appropriation for police motor vehicles, apparatus, equipment, and housing in a 1-year period must not exceed 10 mills of the taxable value of the area in their respective townships for which police protection is to be furnished.

(2) The township board of a township, or the township boards of adjoining townships acting jointly, whether or not the townships are located in the same county, may provide annually by resolution for the appropriation of general or contingent funds for maintenance and operation of police and fire departments.

(3) The township board, or the township boards of adjoining townships acting jointly, may provide that the sums prescribed in subsection (2) for purchasing and housing equipment, for the operation of the equipment, or both, may be defrayed by special assessment on the lands and premises in the township or townships to be benefited, except, beginning in 2002, lands and premises exempt from the collection of taxes under the general property tax act, 1893 PA 206, MCL 211.1 to 211.155, and may issue bonds in anticipation of the collection of these special assessments. The question of raising money by special assessment may be submitted to the electors of the township or townships by the township board, or township boards acting jointly, at a general election or special election called for that purpose by the township board or township boards. The question of raising money by special assessment must be submitted by the township board, or township boards acting jointly, if in the affected township, or in each of the affected townships, the owners of 10% of the land to be made into a special assessment district petition the township board or boards.

(4) If a special assessment district is proposed under subsection (3), the township board, or township boards acting jointly, shall estimate the cost and expenses of the police and fire motor vehicles, apparatus, equipment, and housing and police and fire protection, and fix a day for a hearing on the estimate and on the question of creating a special assessment district and defraying the expenses of the special assessment district by special assessment on the property to be especially benefited, except, beginning in 2002, property exempt from the collection of taxes under the general property tax act, 1893 PA 206, MCL 211.1 to 211.155. The hearing must be a public meeting held in compliance with the open meetings act, 1976 PA 267, MCL 15.261 to 15.275. Public notice of the time, date, and place of the meeting must be given in the manner required by the open meetings act, 1976 PA 267, MCL 15.261 to 15.275. In addition, the township board, or township boards acting jointly, shall publish in a newspaper of general circulation in the proposed district a notice stating the time, place, and purpose of the meeting. If there is not a newspaper of general circulation in the proposed district, notices must be posted in not less than 3 of the most public places in the proposed district. This notice shall be published or posted not less than 5 days before the hearing. On the day appointed for the hearing, the township board, or township boards acting jointly, shall be in session to hear objections that may be offered against the estimate and the creation of the special assessment district. Before January 1, 1999, if the township board, or township boards acting jointly, determine to create a special assessment district, they shall determine the boundaries by resolution, determine the amount of the special assessment levy, and direct the supervisor or supervisors to spread the assessment levy on all of the lands and premises in the district that are to be especially benefited by the police and fire protection, according to benefits received, except, beginning in 2002, lands and premises exempt from the collection of taxes under the general property tax act, 1893 PA 206, MCL 211.1 to 211.155, to defray the expenses of police and fire protection. After December

31, 1998, if the township board, or township boards acting jointly, determine to create a special assessment district, they shall determine the boundaries by resolution, determine the amount of the special assessment levy, and direct the supervisor or supervisors to spread the assessment levy on the taxable value of all of the lands and premises in the district that are to be especially benefited by the police and fire protection, according to benefits received, except, beginning in 2002, lands and premises exempt from the collection of taxes under the general property tax act, 1893 PA 206, MCL 211.1 to 211.155, to defray the expenses of police and fire protection. The township board, or township boards acting jointly, shall hold a hearing on objections to the distribution of the special assessment levy. This hearing must be held in the same manner and with the same notice as provided in this section. The township board, or township boards acting jointly, shall annually determine the amount to be assessed in the district for police and fire protection, shall direct the supervisor or supervisors to distribute the special assessment levy, and shall hold a hearing on the estimated costs and expenses of police and fire protection and on the distribution of the levy. The assessment may be made either in a special assessment roll or in a column provided in the regular tax roll. The assessment must be distributed and must become due and be collected at the same time as other township taxes are assessed, levied, and collected, and must be returned in the same manner for nonpayment. If a township has a July property tax levy, not more than 2 mills of the assessment may be collected at the same time and in the same manner as the July levy. If the collections received from the special assessment levied to defray the cost or portion intended to be defrayed for police and fire protection are, at any time, insufficient to meet the obligations or expenses incurred for the maintenance and operation of the police and fire departments, the township board of the township, or township boards acting jointly, may, by resolution, authorize the transfer or loan of sufficient money from the general fund of the township or townships, to the special assessment police and fire department fund. This money must be repaid to the general fund of the township or townships out of special assessment funds when collected.

(5) The powers granted by this act with respect to police and fire protection may be exercised with respect to police protection alone, fire protection alone, or police and fire protection in combination.

(6) After December 31, 1998, an ad valorem special assessment levied under this act must be levied on the taxable value of the property assessed. After December 31, 2018, a special assessment levied under this act must be spread on the taxable value of the property assessed based on the special benefit provided to the property assessed and may not be based on police and fire protection provided in a prior year to assessed property.

(7) A special assessment imposed under this act must be levied on all properties within the special assessment district established pursuant to this act other than properties exempt from the collection of taxes under the general property tax act, 1893 PA 206, MCL 211.1 to 211.155.

(8) As used in this section, "taxable value" means that value determined under section 27a of the general property tax act, 1893 PA 206, MCL 211.27a.

(9) If the levy of an ad valorem special assessment on the property's taxable value is found to be invalid by a court of competent jurisdiction, the levy of the ad valorem special assessment must be levied on the property's state equalized value.

(10) Bonds issued under this act are subject to the revised municipal finance act, 2001 PA 34, MCL 141.2101 to 141.2821.

**History:** 1951, Act 33, Imd. Eff. May 8, 1951;—Am. 1955, Act 221, Eff. Oct. 14, 1955;—Am. 1970, Act 134, Imd. Eff. July 29, 1970;—Am. 1978, Act 101, Imd. Eff. Apr. 6, 1978;—Am. 1989, Act 81, Imd. Eff. June 20, 1989;—Am. 1998, Act 545, Imd. Eff. Jan. 20, 1999;—Am. 2002, Act 308, Imd. Eff. May 13, 2002;—Am. 2002, Act 501, Imd. Eff. July 15, 2002;—Am. 2018, Act 484, Eff. Jan. 1, 2019.

**POLICE AND FIRE PROTECTION (EXCERPT)**  
**Act 33 of 1951**

**41.810 Fire protection for townships, villages, and qualified cities; "qualified city" defined.**

Sec. 10. (1) This act applies to townships and adjoining townships and incorporated villages and qualified cities. If reference is made in this act to townships, that reference applies to townships and incorporated villages and qualified cities. If reference is made in this act to township boards, that reference applies to township boards and the legislative bodies of incorporated villages and qualified cities. A township, incorporated village, or qualified city shall not use this act to lessen the number of paid full-time firefighters in that township, incorporated village, or qualified city.

(2) As used in this act, "qualified city" means either of the following:

(a) A city with a population of less than 15,500.

(b) A city with a population of 15,500 or more if the question of raising money by special assessment and the amount of the special assessment to be levied annually under this act is approved by a majority of the electors in the special assessment district. The amount of the special assessment to be levied annually under this act that was approved under this subdivision must not be increased unless that increase is first approved by a majority of the electors in the special assessment district.

**History:** Add. 1960, Act 51, Eff. Aug. 17, 1960;—Am. 1966, Act 105, Imd. Eff. June 22, 1966;—Am. 2004, Act 463, Imd. Eff. Dec. 28, 2004;—Am. 2020, Act 64, Imd. Eff. Mar. 17, 2020;—Am. 2021, Act 113, Imd. Eff. Nov. 10, 2021;—Am. 2022, Act 228, Eff. Mar. 29, 2023.

## MEMORANDUM

Department of Public Services

**DATE:** May 8, 2023

**TO:** Thomas M. Markus, City Manager

**FROM:** Scott D. Zielinski, DPS Director  
Carrie A. Laird, Parks & Recreation Manager

**SUBJECT:** Pat Andrews Tribute

---

### INTRODUCTION:

Based on Commission direction from the [March 13, 2023](#) City Commission meeting, a seating plaza with a little free library/or book box in order to honor Patricia "Pat" Andrews is described in this report along with a cost estimate.

### BACKGROUND:

To celebrate and honor the life of Patricia "Pat" Andrews (November 5, 1921-September 1, 2021), a beloved and active in the community resident of Birmingham, a retired teacher and historian, and lifelong learner, staff under Commission direction has put together a schematic and cost estimate for a plaza and gathering area with an opportunity for reading and learning for all.

The plaza area will mimic the circular plaza that is located at the corner of Chesterfield and Maple (pictured below) and be located on the eastern corner (Maple and Fairfax) of the Station 2 property.

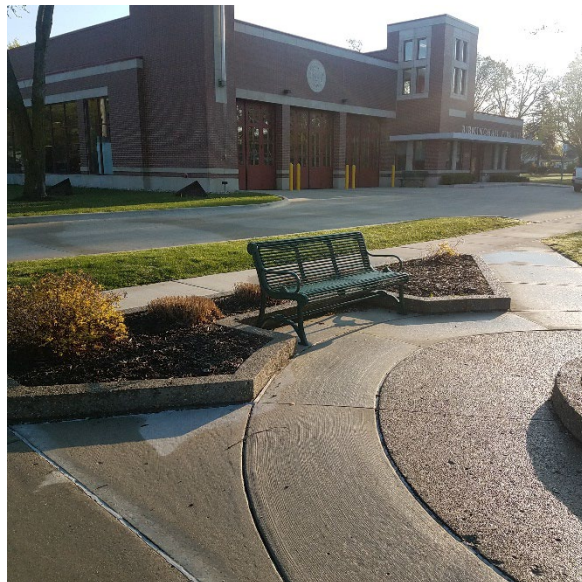

Site of proposed Pat Andrews plaza with Little Library (Maple & Fairfax):

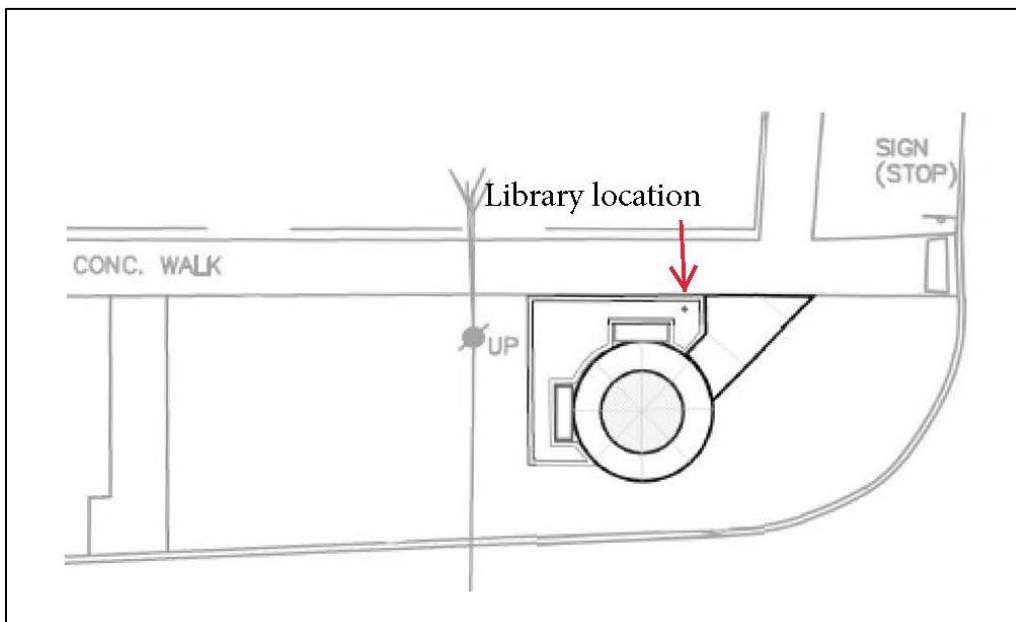
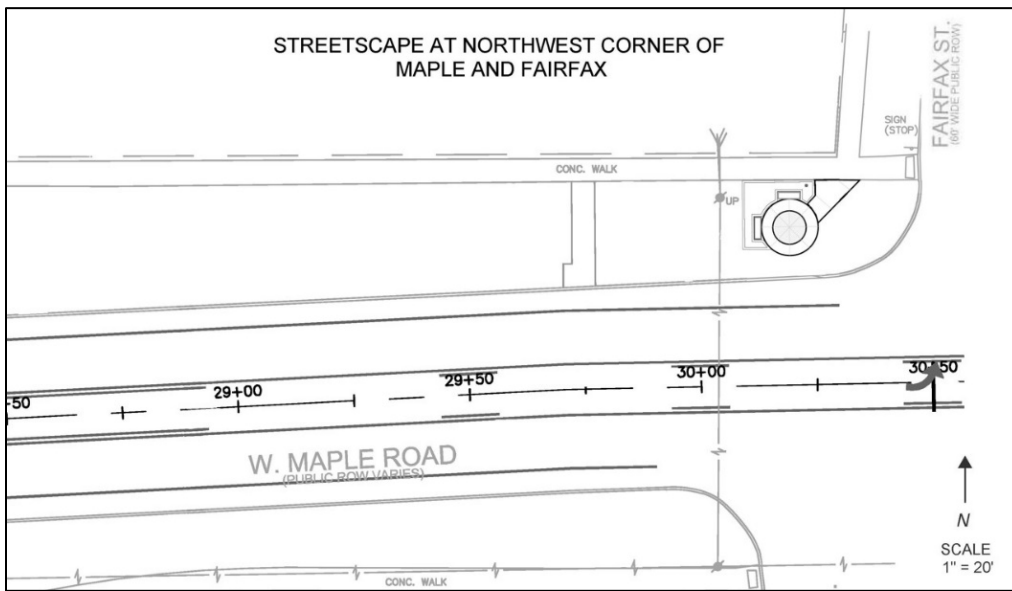

#### FISCAL IMPACT:

Engineering has put together an opinion of probable costs for this streetscape improvement, attached. The total cost for a new plaza with two (2) benches, landscaping and a custom built library book box to replicate the Andrews' residence is estimated to be at this time \$36,380.00. Should more time be required for funding purposes, this estimate may change.

Members of the community, family and friends of Pat Andrews have contributed \$1,075 to date. The City has not budgeted to accomplish this project.

#### PUBLIC COMMUNICATIONS:

The City has a donation page and it's possible to add this project as a potential donation opportunity [bhamgov.org/donate](http://bhamgov.org/donate).

#### SUMMARY:

In order to provide a tribute location for Patricia Andrews, staff recommends a streetscape plaza with a little library at the corner of Maple and Fairfax. This location is appropriate as it's located in the right of way and would not interfere with any future expansion of the Fire Department or training activities that currently take place in the open green space, yet it's still near to the Fire Department. Pat Andrews was a lifelong advocate for the outstanding services of the Birmingham Fire Department and lived nearby, close enough to walk over fresh homemade cookies!

A custom built little library box, replicating the residence of and commemorating the life of Pat Andrews would be located in the landscape bed, at the entrance to the plaza, near the existing sidewalk (Andrews residence pictured below). One could gather together with neighbors, pick out a book to read, find a shady spot in the lawn, or sit on one of the benches located in the plaza. A plaque to honor Pat Andrews would be placed in a visible location as well.



#### ATTACHMENTS:

- Engineer's Opinion of Probable Cost
- Streetscape Sketch
- Examples of Little Free Library's built by the DPS





4/28/2023

**ENGINEER'S OPINION OF PROBABLE COST PRELIMINARY DESIGN  
STREETScape AT NORHTWEST CORNER OF MAPLE AND FAIRFAX**

NO.	ITEM DESCRIPTION	PAY UNIT	TOTAL QUANTITY	UNIT PRICE	TOTAL AMOUNT
<b>PAVING PAY ITEMS</b>					
1	Earth Excavation	CY	10	\$20.00	\$ 200.00
2	Concrete Sidewalk, 4"	SF	190	\$10.00	\$ 1,900.00
3	Concrete Sidewalk, 4", Exposed Aggregate, Scoring Treatment	SF	40	\$15.00	\$ 600.00
4	Concrete Curb, Exposed Aggregate, 6", Planters	LF	70	\$125.00	\$ 8,750.00
<b>SUBTOTAL PAVING PAY ITEMS</b>					<b>\$ 11,450.00</b>
<b>STREETSCAPING</b>					
5	Benches	EA	2	\$2,500.00	\$ 5,000.00
6	Custom Built Little Library Installed Including Plaque	EA	1	\$8,580.00	\$ 8,580.00
7	Planting Allowance	LS	1	\$500.00	\$ 500.00
<b>SUBTOTAL STREETSCAPING</b>					<b>\$ 14,080.00</b>
<b>GENERAL PAY ITEMS</b>					
8	Topographic Survey	LS	1	\$2,500.00	\$ 2,500.00
9	Design (One Concept and One Construction Drawing)	LS	1	\$4,700.00	\$ 4,700.00
10	Construction Staking	LS	1	\$2,500.00	\$ 2,500.00
11	Mobilization	LS	1	\$1,000.00	\$ 1,000.00
12	Topsoil, 3"	SY	10	\$5.00	\$ 50.00
13	Inlet Filter	EA	1	\$100.00	\$ 100.00
<b>SUBTOTAL GENERAL PAY ITEMS</b>					<b>\$ 10,850.00</b>

**OVERALL TOTAL - ENGINEER'S OPINION OF PROBABLE COST PRELIMINARY DESIGN                      \$36,380.00**

# STREETSCAPE AT NORTHWEST CORNER OF MAPLE AND FAIRFAX

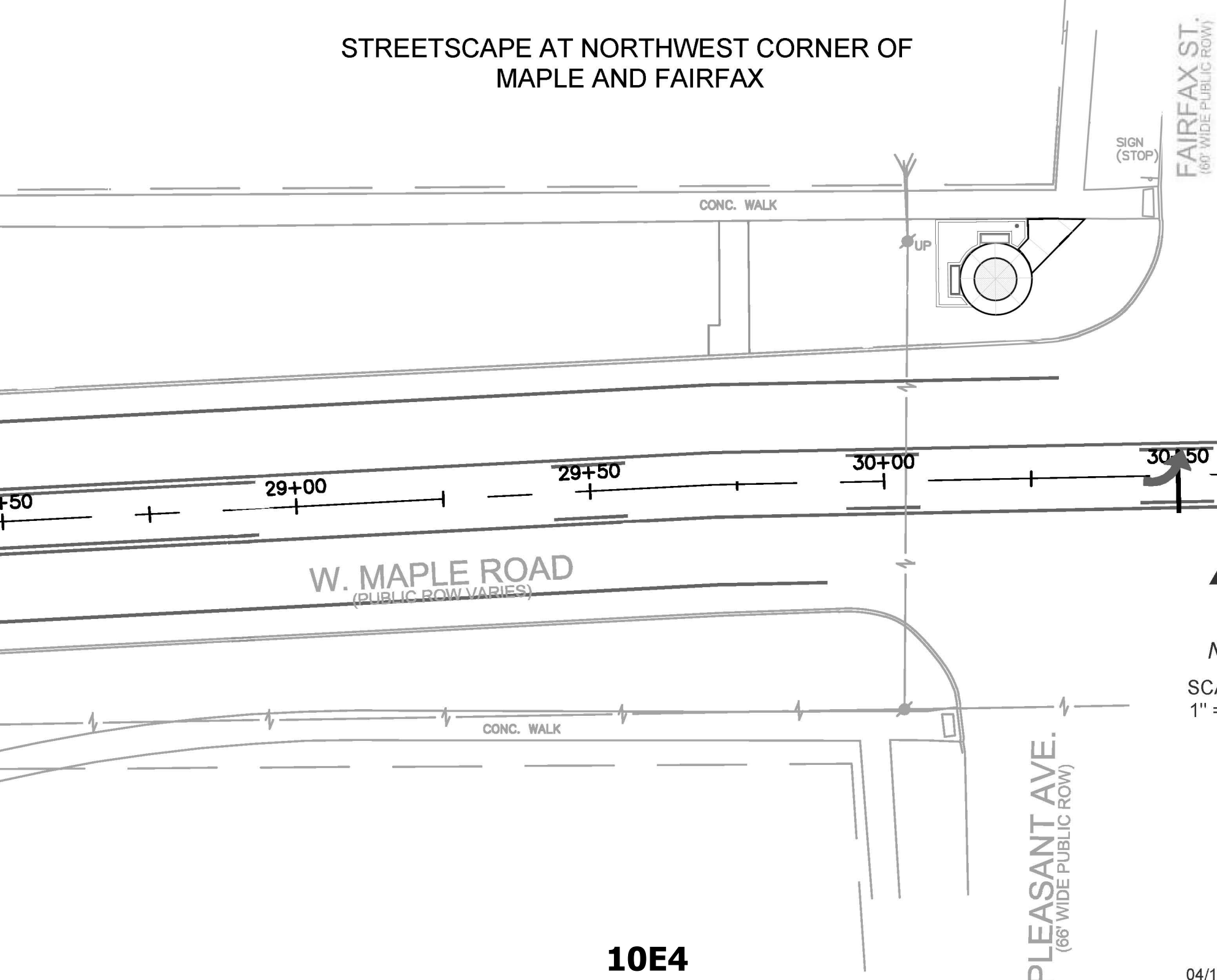

FAIRFAX ST.  
(60' WIDE PUBLIC ROW)

W. MAPLE ROAD  
(PUBLIC ROW VARIES)

PLEASANT AVE.  
(66' WIDE PUBLIC ROW)

**10E4**

04/13/2023



Barney

10E4

Littlefield Library  
10000 Littlefield Ave  
Littlefield, VA 22972

# Hogsworth

LittleFree  
Take a Book  
Character # 60296



Share Books

Take a Book



Return a Book™

10E4

Please,  
Be kind to Hogsworth. His friends from the Birmingham Police Department are watching out for him.

City of Birmingham  
A World of Community





Illustration by Bénédicte Muller

ESSAY

## THE CURIOUS SIDE EFFECTS OF MEDICAL TRANSPARENCY

*When we peer into our patient portals, we don't always see ourselves more clearly.*

By Danielle Ofri

April 29, 2023

One afternoon not long ago, I sat entering notes into a patient's medical record. She was in her forties, and her labs showed anemia. The causes of

INFORMATION ONLY

anemia range from menstruation to cancer, and so pinpointing the correct underlying diagnosis is critical. Physicians are trained to formulate a full roster of possibilities, known as the differential diagnosis, and then to work down the list systematically. We're taught to cast a wide net—celiac disease, parasitic infections, thalassemia, lead poisoning, liver disease, B12 deficiency, myeloma, sickle-cell disease, G6PD deficiency—because you'll never make a diagnosis if you haven't included it in your differential.

But I hesitated before entering my differential into the computer system. Should I include the more serious possibilities, even though they were much less likely? In the past, I wouldn't have thought twice about it, as the chart served primarily as a tool for the medical team to communicate among ourselves. But a new law, the 21st Century Cures Act, had recently been fully implemented, making medical records open to patients by default, in real time, including doctors' notes. My inbox was already jammed with panicked messages from people convinced that they had catastrophic illnesses, based on minuscule lab discrepancies and panic-inducing Google searches. How would my patient react to seeing my ruminations about possible colon cancer or duodenal ulcer in the note?

---

**Sign up for The Daily.**

Receive the best of *The New Yorker*, every day, in your in-box.

E-mail address \_\_\_\_\_

Your e-mail address

Sign up

By signing up, you agree to our [User Agreement](#) and [Privacy Policy & Cookie Statement](#).

One of the earliest known medical records—an account of wound treatment—was written on papyrus in Egypt, around 1600 B.C. Its intended audience seems to have been fellow-healers, who could learn from it. More than a thousand years

**INFORMATION ONLY**

later, Hippocrates helped develop the concept of the medical-case history, which was likely geared toward educating and informing other practitioners. This contributed to a physician-centric view of the medical record, which has endured. Into the nineteen-seventies, patients in most U.S. states could obtain their medical records only with the help of a lawyer. In 2000, the HIPAA Privacy Rule—which clarified how the health-care industry should implement the Health Insurance Portability and Accountability Act of 1996—required organizations to disclose most kinds of medical information to patients upon request. But health-care organizations were under no obligation to eliminate the paperwork, fees, or surly clerks that stood between patients and their records.

As medical records inched from paper to computer during the nineteen-nineties, a few institutions began experimenting with patient portals—Web sites for patients to access their records. These sites, which began appearing more widely in the two-thousands, were clunky to use, and there wasn't much in there beyond appointments and some test results. But, in 2009, as part of its attempt to drag the U.S. economy out of recession, the federal government offered incentive payments to medical organizations that could demonstrate “meaningful use” of electronic medical records. Requirements for the funding came to include the ability for patients to “view, download, and transmit” their medical information. With money now on the table, patient portals proliferated.

In 2010, Jan Walker and Tom Delbanco, who have backgrounds in nursing and internal medicine, respectively, founded a research collaborative called OpenNotes, based at Beth Israel Deaconess Medical Center in Boston. This initiative went a step further and experimented with allowing patients to read the actual notes that their doctors were writing. Patients in the initial studies were overwhelmingly enthusiastic about the idea. For physicians, this was a radical change: lab values and radiology reports were neutral information, but notes felt personal. The Cures Act went into full effect in the spring of 2021, granting patients access to their records by default, so that they didn't have to request it. In the brief lull between

**INFORMATION ONLY**

COVID-19's soul-crushing winter and the start of the deadly Delta wave, the medical profession abruptly found itself staring into a two-way mirror.

Transparency has always been seen as a hallmark of honesty and integrity. The logic is familiar: democracies aspire to be transparent, but dictatorships are opaque; faithful spouses are guileless, while philanderers lie; reputable businesses operate in the open, but shady operations literally draw the shades. Collectively, we've embraced Louis Brandeis's dictum that sunlight is the best disinfectant. We demand transparency in government, charitable institutions, nutrition labels, and middle-school grading rubrics. The medical record should be no different.

And yet, in writing the medical note for my patient with anemia, I felt an awkwardness creeping in. There was something disquieting about knowing that my every word might be scrutinized. The academic purist in me pressed for a thorough differential and a full accounting of my thought process—to avoid error, but also to accurately inform the next physician about the current state of affairs. I worried, however, about downstream angst, both for me and for the patient. She had been transparent with me, sharing her story, her body, her blood chemistry. She'd answered personal questions about her medical history, sexual partners, drug and alcohol use, and dietary habits. Still, I hesitated when it came time for me to be fully transparent with her.

In the end, I dashed off something like “anemia eval” —a pathetic skeleton of a note that I wouldn't have tolerated from a medical student—and tore off the exam-table paper in preparation for the next patient. I felt rushed, annoyed, and frankly disgusted at my dumbing down of the chart. And I couldn't tamp a rising coil of unease. Why had a system designed to encourage transparency resulted in my drawing the curtain?

**I**n 2008, Ethan Bernstein, an associate professor at Harvard Business School, travelled with a team of students to a vast mobile-phone-manufacturing plant in southern China. Managers scanned stadium-sized production floors, surveying

**INFORMATION ONLY**



entire assembly lines at a glance. Ubiquitous digital monitors provided real-time data for all to see. A rainbow palette of hats and uniforms instantly pegged the position and rank of fourteen thousand employees, among whom Bernstein's undergrads were discreetly embedded.

The students, who'd been born in China, lived, worked, ate, and socialized with their colleagues. They found that, as in any high-pressure workplace, employees were constantly fashioning more agile strategies for getting the job done, often bypassing procedures handed down by bureaucrats from on high. What amazed Bernstein was the lengths to which workers went to conceal their innovations. One told him, "It's most efficient to hide it now and discuss it later." Ironically, the plant's transparency enabled this subterfuge: the colored hats that allowed management to identify each worker's position also let workers spot managers from across the floor, giving them time to camouflage their improvisations. As the managers made their rounds, they became loci of decreased productivity.

Bernstein's team hung a curtain in the factory, preparing to conduct an experiment that involved observing assembly lines on one side, and then comparing them with the control lines on the other. But when a worker offhandedly mused about how much better it would be if the curtain completely closed them in on all sides, Bernstein went with her idea, instead. In just a week, the mere shielding of these assembly lines increased productivity by as much as ten to fifteen per cent—a change that persisted for the five months that Bernstein was able to continue observing. Instead of hiding their various tweaks and improvements, the workers behind the curtains could share them with their colleagues without fear of drawing unwanted attention; they even sometimes cross-trained one another, making it easier for people who worked different positions to cover for one another. "When you get watched, you lose autonomy," Bernstein told me. The result is what he calls the transparency paradox: well-intentioned measures meant to increase transparency and promote productivity, creativity, and compliance

**INFORMATION ONLY**

often accomplish the opposite. Observation is not a neutral process; human beings react.

**T**ransparency in government, to the extent that it exists, has been hard-won. For most of its history, Congress could be witnessed only by the few members of the public lucky or connected enough to snag seats in the gallery. From time to time, radio broadcasts captured Congress at work; in 1947, a single live-television broadcast of the opening session of the House of Representatives served as the first salvo in the fight for fuller public access. It was followed by spotty televised coverage of the occasional Presidential speech, and then by an outright ban on television cameras in Congressional sessions and committee hearings, in 1952. In the Watergate-chastened nineteen-seventies, calls for transparency led to a brief test of closed-circuit television, in 1977.

That year, a journalist named Brian Lamb submitted a proposal to the governing body of the newly emerging cable-television industry suggesting the creation of a public-affairs channel to show gavel-to-gavel coverage of congressional proceedings. The Cable-Satellite Public Affairs Network (C-SPAN) launched in 1979. It touted itself as “your unfiltered view of government”; the comedian Elayne Boosler has referred to it as “*Wild Kingdom* but with congressmen.” C-SPAN was hailed as a win for transparency and accountability. Representative Al Gore, who was the very first lawmaker to appear on C-SPAN, argued that it offered “a solution for the lack of confidence in government.” Because it does not filter or edit coverage, C-SPAN is generally considered unbiased—a transparent view.

Along with other lawmakers, Newt Gingrich—who arrived in Congress shortly after C-SPAN did—quickly realized the potential of the medium. Members of Congress delivered more pugnacious speeches at the end of the day, which appeared to stun their opponents into silence—sometimes because nearly everyone had gone home, a fact that the cameras didn’t reveal. (Later, cameras started panning the room.) The researchers Gloria Gennaro and Elliott Ash have

**INFORMATION ONLY**

examined the so-called C-SPAN effect, demonstrating a correlation between the “emotionality” of lawmakers’ rhetoric and the levels of C-SPAN viewership in their districts. They also found that exposure on C-SPAN has no measurable effect on legislative efforts—perhaps because such efforts often require detailed deal-making and uncomfortable trade-offs that are easier managed in quiet backrooms. C-SPAN, therefore, might not be showing us lawmakers in the wild so much as encouraging them to grandstand to the camera in ways that can be antithetical to the actual work of governing. (By contrast, increased coverage by local news does appear to correlate with legislative progress, though without impact on the emotionality of lawmakers’ oratory.)

**T**hese counterintuitive effects sit awkwardly alongside our valorization of transparency. David Pozen, a soft-spoken law professor at Columbia University, told me point-blank that “transparency has a proven track record of failing to deliver on its ostensible benefits.” Open-file discovery, for example, is a transparency effort intended to level the playing field during litigation; it requires prosecutors to share the results of their investigations with defense teams, so that defendants can make more informed decisions about plea bargains. These disclosures also protect defendants from being surprised during trial by witnesses or evidence for which they haven’t prepared. But analyses have found that these laws haven’t always resulted in meaningful improvements for defendants. This might be because most defendants are poor, and their overworked, underpaid public defenders can’t effectively utilize the additional information. But police and prosecutors may also change their behavior once they know that whatever they uncover will be shared with the defense.

Transparency, Pozen told me, “invites conceptual confusion about whether it’s a first-order good that we’re trying to pursue for its own sake, or a second-order good that we’re trying to use instrumentally to achieve other goods.” In the first case, we might feel that transparency is an ideal always worth embracing, whatever

**INFORMATION ONLY**

the costs. In the second, we might ask ourselves what it's accomplishing, and how it compares with other routes to the same end.

“There is a standard view that transparency is all good—the more transparency, the better,” the philosopher C. Thi Nguyen, an associate professor at the University of Utah, told me. But “you have a completely different experience of transparency when you are the subject.” In a previous position, Nguyen had been part of a department that had to provide evidence that it was using state funding to satisfactorily educate its students. Philosophers, he told me, would want to describe their students’ growing reflectiveness, curiosity, and “intellectual humility,” but knew that this kind of talk would likely befuddle or bore legislators; they had to focus instead on concrete numbers, such as graduation rates and income after graduation. Nguyen and his colleagues surely want their students to graduate and earn a living wage, but such stats hardly sum up what it means to be a successful philosopher.

In Nguyen’s view, this illustrates a problem with transparency. “In any scheme of transparency in which you have experts being transparent to nonexperts, you’re going to get a significant amount of information loss,” he said. What’s meaningful in a philosophy department can be largely incomprehensible to non-philosophers, so the information must be recast in simplified terms. Furthermore, simplified metrics frequently distort incentives. If graduation rates are the metric by which funding is determined, then a school might do whatever it takes to bolster them. Although some of these efforts might add value to students’ learning, it’s also possible to game the system in ways that are counterproductive to actual education.

Transparency is often portrayed as objective, but, like a camera, it is subject to manipulation even as it appears to be relaying reality. Ida Koivisto, a legal scholar at the University of Helsinki, has studied the trade-offs that flow from who holds that camera. She finds that when an authority—a government agency, a business, a public figure—elects to be transparent, people respond positively, concluding

**INFORMATION ONLY**

that the willingness to be open reflects integrity, and thus confers legitimacy. Since the authority has initiated this transparency, however, it naturally chooses to be transparent in areas where it looks good. Voluntary transparency sacrifices a degree of truth. On the other hand, when transparency is initiated by outside forces—mandates, audits, investigations—both the good and the bad are revealed. Such involuntary transparency is more truthful, but it often makes its subject appear flawed and dishonest, and so less legitimate. There’s a trade-off, Koivisto concludes, between “legitimacy” and “the ‘naked truth.’”

Finn Janning, a Danish philosopher based in Barcelona, studies the gap between self-knowledge and self-deception. Under the guise of transparency, he told me, we can deceive ourselves, reasoning that we are good because we are open about what we are doing. (Modern-day autocrats often present themselves as “transparent.”) He also noted that transparency is not necessarily a positive motivating force. “Transparency does not lead to you acting better,” Janning said. “On the contrary, you try to fit into the norm. You act in a predictable way.”

**F**rom my end of the stethoscope, it’s always seemed obvious that patients should own their medical records, and be able to see them. But openness can be challenging in practice. When our hospital initially rolled out its patient portal, a few of my older patients asked that I remove references to erectile dysfunction from their medical records. Their adult children handled the household tech, they explained, and my patients preferred to keep their Viagra prescriptions private. In other cases, multiple family members can access a patient’s chart, messaging me about test results and treatment plans, and it can be complicated to deduce the hierarchy of responsibility. Advocates have raised increasing concerns about the ease with which abusers can gain access to victims’ medical records; health-care settings have traditionally been secure places for people experiencing domestic violence, elder abuse, and human trafficking, but, with medical records becoming more accessible, patients may feel less certain that their words are safe.

At the same time, there are remarkable upsides to the transparent medical record. Patients are able to review their diagnoses, medications, and treatments at their own pace. They are able to share information with family members if they choose. They can spot errors—medications they are no longer taking, medical history that’s missing, allergies that aren’t noted. They can prepare for their next visit, and perhaps feel on more equal footing with their doctor. And they can obtain test results without the interminable wait for the doctor’s call.

Medicine is a highly specialized field, and like philosophy it involves the challenge of bridging the gap between experts and nonexperts. Regulations coming out of the Cures Act prohibit “information blocking,” and in effect require that test results and doctors’ notes be released immediately to patient portals. In practice, this means that patients often see results before their doctors do and are presented with a fire hose of raw data, shorn of context. And yet on many patient portals, because of algorithms that offer only a binary distinction between normal and abnormal, lab values that stray a meaningless half percentage point out of range are labelled as “abnormal” along with results that have grave portent. Doctors’ ubiquitous use of multicomponent lab panels, which bundle together many different tests, virtually guarantees that every patient receives at least one “abnormal,” which, in our hospital’s system, is written in blood-red letters with garish yellow highlighting, plus an exclamation point, just in case the takeaway hasn’t been fully conveyed. Even seemingly straightforward yes-or-no results, such as those from H.I.V. or COVID tests, can be easily misinterpreted, since false positives and false negatives occur depending on the course of the disease and the operating characteristics of the test. Meanwhile, results such as CT scans and MRIs often contain paragraphs’ worth of information that looks alarming but isn’t. Try reading the CT report of your lumbar spine and not coming away convinced that you’ll be paralyzed for life.

Patients turn from the portal to Google, then flood doctors’ in-boxes with messages, panicked by the possibility that they have cancer or multiple sclerosis or

**INFORMATION ONLY**

any of an assortment of inglorious diseases that appear on the Internet grossly out of proportion to their actual prevalence. But some abnormal test results will indeed be real, and some will be seriously concerning. In our current transparent system, tests showing brain atrophy or liver masses are released to the portal in the same manner as cholesterol levels and blood-pressure readings. For some patients, discovering these results on their own can be empowering; for others, it can be catastrophic. In one devastating stretch of twenty-four hours, two of my patients learned of their cancers' metastatic reappearance by way of the portal. Their inboxes pinged with new test results; they read them before either their oncologist or I had even seen the scans, let alone called.

Each morning, I log into our medical-record system with a certain amount of dread. Which will I tackle first—the torrent of test results or the deluge of responses it's inspired? Some patients will have to be talked down from a ledge over a minor lab abnormality. Far worse is the serious result to which I haven't yet had time to formulate a response: a biopsy result for which I've not yet tracked down the appropriate specialist to sketch a road map, or an adrenal mass on a CT scan for which I've not yet orchestrated the intricate endocrine evaluation. In the past, I'd do the legwork before I called the patient. Now that buffer is gone, and I am pressured to act immediately: the patient has seen the result, and further delay would be unconscionable. This timbre of rush imperils thoughtful analysis, and I worry incessantly about missteps.

**H**istorically, the medical profession has had little use for transparency. Grave diagnoses were routinely withheld, on the assumption that they would further patient suffering. The Black men who participated in the infamous syphilis study at Tuskegee, in 1932, were not told that the trial aimed to study untreated syphilis, nor were they made aware of—or offered—penicillin, which became widely available the following decade. Generations of patients with

mental illness were often institutionalized with little or no information released to them or their families.

There are strong ethical reasons, therefore, to pursue transparency in the medical record. But, as Pozen points out, we should not be lulled into treating transparency as a first-order good, like compassion, respect, avoiding harm, or putting the patient first. In a recent survey of more than eight thousand patients conducted by OpenNotes, nearly all the respondents said that they preferred immediate access to their test results, even if their doctors hadn't yet reviewed those results. This was true even for the vast majority of people who said that they'd experienced increased worry in the face of results that were abnormal. It's an understandable preference—one that every patient has the right to hold. But simply throwing open the medical record and calling it a day allows us to rest on our laurels without doing the hard work of fixing what's inside. Police departments often point to body cameras as evidence of accountability without actually addressing the problem of police violence. Lawmakers can laud themselves for their transparency via C-SPAN without having to engage in the gritty compromise needed to move legislation forward. Transparency might better be viewed as one possible means to desirable ends—not an end in and of itself.

It might also be wise to recognize that there are times when patients themselves may want to draw the curtain. Some years ago, I cared for an elderly man who'd been admitted to the hospital with weight loss and a swollen abdomen. A CT scan revealed an aggressive cancer that had already spread to multiple organs. It was clear that he was at a terminal stage. The patient's son insisted that I not tell his father anything. It would crush his spirit, I remember him saying. The son explained that, in his culture, families didn't tell elders that kind of news.

On a slate-gray winter afternoon, I pulled a chair up to my patient's bedside and asked him what he understood thus far. He told me he had a stomach illness that was preventing him from eating. I explained that we now had more information.

**INFORMATION ONLY**



Ordinarily, this would be where I'd gently work my way into what is by far the hardest conversation a doctor can have with a patient. This time, though, I started with a question: "How much would you like to know?" I told him that he could have as much or as little detail as he wanted, or none at all. I assured him that I could keep his answer—and even how much he chose to know—confidential from his family.

He was silent for a few moments. Our gazes drifted out the window, toward the barges trundling down the East River. Then he replied that he wasn't interested in the names of the medications we were prescribing or the details of the treatments. He didn't want to know the results of the CT scan or the biopsy.

I took his hand and reassured him that we would take care of his stomach illness. The son handled the paperwork, the phone calls, the medications, and the necessary arrangements. The father watched television and napped. Several weeks later, he died at home, by all accounts peacefully. ♦

---

## NEW YORKER FAVORITES

---

- A security camera for the entire planet.
- Cargo ships are among the dirtiest vehicles in existence. Can an ancient technology clean them up?
- Saving the climate will depend on blue-collar workers. Can we train enough of them before time runs out?
- In India, a clean-power plant the size of Manhattan could be a model for the world—or a cautionary tale.
- Seeking a heat shield for the most important ice on Earth.
- A case for climate optimism, and pragmatism, from John Podesta.

INFORMATION ONLY

- The climate solutions we can't live without.

Sign up for our daily newsletter to receive the best stories from *The New Yorker*.

---

*Danielle Ofri is a primary care doctor at Bellevue Hospital and the author of "When We Do Harm: A Doctor Confronts Medical Error."*

---

More: [Transparency](#) [Medical Records](#) [Patients](#) [Doctors](#) [Information](#) [Health Care](#) [Medicine](#)

---

## THE DAILY

The best of *The New Yorker*, every day, in your in-box, plus occasional alerts when we publish major stories.

E-mail address

Your e-mail address

Sign up

By signing up, you agree to our [User Agreement](#) and [Privacy Policy & Cookie Statement](#).

---

Read More

---

INFORMATION ONLY

BOOKS

THE MAKING OF JACKIE KENNEDY

As a student in Paris and a photographer at the Washington Times-Herald, the future First Lady worked behind the lens to bring her own ideas into focus.

By Thomas Mallon

CROSSWORD

THE CROSSWORD: THURSDAY, APRIL 27, 2023

A beginner-friendly puzzle.

By Patrick Berry

INFORMATION ONLY

THE FRONT ROW

## THE GREATEST INDEPENDENT FILMS OF THE TWENTIETH CENTURY

A counter-canon of masterworks by filmmakers who took control of the means of production.

By Richard Brody

NAME DROP

NAME DROP: THURSDAY, APRIL 20, 2023

Can you guess the notable person in six clues or fewer?

**INFORMATION ONLY**

By Will Nediger

[Cookies Settings](#)

INFORMATION ONLY

**LOCAL NEWS**

# City council approves recreational marijuana shops in Taylor

The 5-2 vote passed the zoning ordinance allowing recreational marijuana sales in Taylor

**Jacqueline Francis**, Reporter

**Brandon Carr**, Digital Content Producer

Published: **May 2, 2023 at 10:27 PM**

Updated: **May 2, 2023 at 11:20 PM**

Tags: **Taylor, Wayne County**



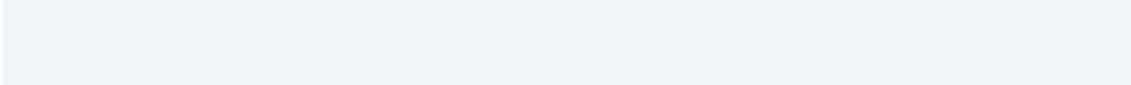

**TAYLOR, Mich.** – After months of no action, the **City of Taylor** is one step closer to opening recreational marijuana shops.

Taylor City Council passed two marijuana ordinances Tuesday (May 2) night after voters approved the measure last fall.



The primary ordinance focused on zoning, allowing anywhere from three to five recreational marijuana dispensaries to open in approved industrial areas of the city.

“It’s not going to be on every corner,” said Council Chairman Doug Geiss. “It’s really not going to be very visible, but the areas that we chose are going to be close to freeways, so it will be accessible for people to come to Taylor to purchase (recreational marijuana), but also for our residents, not having to drive five to ten miles.”

There was some pushback from residents about revising the 2,500 feet rule.

The ballot measure approved by voters stated that recreational marijuana facilities would be a minimum of 2,500 feet from protected areas like schools and churches.

“Twenty-five hundred feet would’ve meant that there were no parcels,” Geiss said. “So what we did is use natural barriers. A freeway is a natural barrier.”

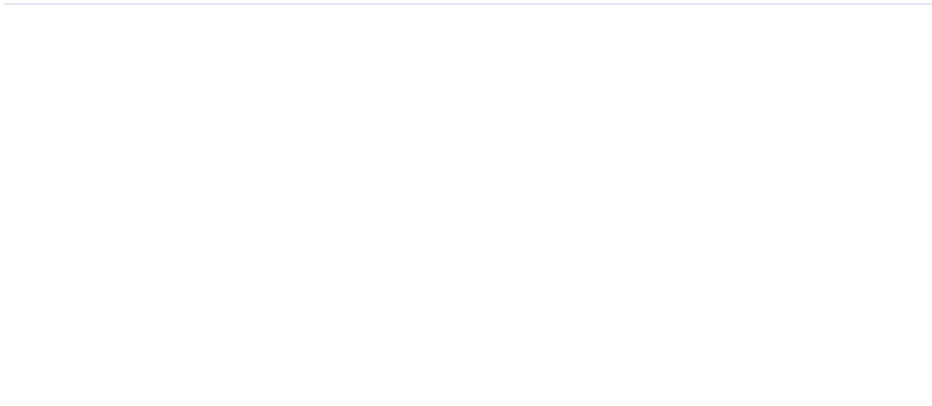

For example, a recreational marijuana store can be located on the other side of the freeway from a residential area, even if the two locations are not 2,500 feet apart.

Those against the ordinance expressed concern about dispensaries being too close to children.

“Everywhere you turn, there are pot stores, and that is very sad for children,” one resident said while addressing the council Tuesday night.

On the other side of the debate, advocates for recreational marijuana sales were excited about the ordinances passed.

“It feels great,” said David Mellert. “We’ve been working on it for a very long time, and we made some concessions, but we are on the right path.”

The city will begin accepting applications on Oct. 1.

*Copyright 2023 by WDIV ClickOnDetroit - All rights reserved.*

**ABOUT THE AUTHORS:**



**Jacqueline Francis**

Jacqueline Francis is an award-winning journalist who joined the WDIV team in September 2022. Prior to Local 4, she reported for the NBC affiliate in West Michigan. When she’s not on the job, Jacqueline enjoys taking advantage of all the wonders Michigan has to offer, from ski trips up north to beach days with her dog, Ace.

[email](#) [twitter](#)



**Brandon Carr**

Brandon Carr is a digital content producer for ClickOnDetroit and has been with WDIV Local 4 since November 2021. Brandon is the 2015 Solomon Kinloch Humanitarian award recipient for Community Service.

[email](#) [twitter](#)

**About Me**

**What is your total annual income?**

- \$0-\$30,000
- \$31,000-\$60,000
- \$61,000-\$120,000
- \$121,000+
- Prefer not to answer

**Update**



---

## Fwd: How DTE, Consumers Energy operate

1 message

---

**Tom Markus** <tmarkus@bhamgov.org>  
To: Alex Bingham <abingham@bhamgov.org>

Mon, Apr 24, 2023 at 8:02 AM

Copy DTE article to next info only

----- Forwarded message -----

From: **thomas markus** <tmsquared20@gmail.com>  
Date: Mon, Apr 24, 2023 at 8:01 AM  
Subject: Fwd: How DTE, Consumers Energy operate  
To: Tom Markus <tmarkus@bhamgov.org>

----- Forwarded message -----

From: **Daily Briefing by Freep.com** <noreply@reply.freep.com>  
Date: Mon, Apr 24, 2023 at 7:03 AM  
Subject: How DTE, Consumers Energy operate  
To: <tmsquared20@gmail.com>

**Detroit Free Press**

[Read in browser](#)

# The Daily Briefing

YOUR MORNING NEWS ROUNDUP

Mon Apr 24 2023

---

**INFORMATION ONLY**



**Leah Olajide** | Newsletter editor



DTE crew members worked on downed power lines behind houses off of Thomas Avenue in Warren in Feb. 2023.

Mandi Wright, Detroit Free Press

***Good morning, today is Monday. Our week begins with the following news ...***

Detroit-based DTE Energy Co. and Jackson-based Consumers Energy are in the spotlight after an ice storm hit the state in late February and left more than 700,000 customers without electricity. This was followed by a winter storm in early March.

[Executives appeared before Michigan lawmakers to defend their response to the storms.](#) The Michigan Public Service Commission, a state agency that regulates the utilities and approves rate increases,

**INFORMATION ONLY**

[held a series of public town halls](#) last month [to hear from customers affected by power outages](#).

It's likely these two companies will receive further scrutiny as they are undergoing transformational change. More severe storms are expected and the grid continues to age. [This story provides an inside look at the companies and explains how they plan to improve reliability](#) .



Alex Bingham &lt;abingham@bhamgov.org&gt;

---

## Fwd: USA TODAY: Bans on gas leaf blowers and lawn mowers are beginning to spread

---

Ellie N <granee54@gmail.com>  
o: city-commission@bhamgov.org

Mon, May 1, 2023 at 11:08 AM

Good Morning, City Commissioners. As a concerned citizen about the issue of NOISY and POLLUTING gas leaf blowers this caught my eye. Why not do something about it city-wide? There was talk once about having at least a day a week where they are not to be used but I don't know if it went anywhere. Also, you could put a time ban in, say not to be used after 7pm - that gives the working person a chance to do it after work.

I, for one, am disturbed with the constant buzzing and blasting of these hideous machines; our neighbor across the street has their lawn done by a perfectionist on Friday nights and my screened in porch is right across from them. Yes, I used the face to face option to no avail; he didn't care about the peace of the neighborhood at 8:30 pm. And now I know the full extent of their pollution - "Environmentalists say using a commercial gas leaf blower for an hour produces emissions equal to driving from Denver to Los Angeles." as quoted in the article.

Thank you for your attention.

Ellie Noble  
1160 Lake Park Dr.

----- Forwarded message -----

From: **Ellie Noble** <granee54@gmail.com>

Date: Mon, May 1, 2023 at 9:23 AM

Subject: USA TODAY: Bans on gas leaf blowers and lawn mowers are beginning to spread

To: Ellie Noble <granee54@gmail.com>

### **Bans on gas leaf blowers and lawn mowers are beginning to spread**

The bans typically apply to new equipment and are popping up from Vermont to California. Proponents say it's good for the climate, health and noise.

Read in USA TODAY: [https://apple.news/A2\\_\\_DDtDnRVCnMUm5Y5tFZA](https://apple.news/A2__DDtDnRVCnMUm5Y5tFZA)

Shared from [Apple News](#)

Sent from my iPhone

--

You received this message because you are subscribed to the Google Groups "City Commission" group.

To unsubscribe from this group and stop receiving emails from it, send an email to [city-commission+unsubscribe@bhamgov.org](mailto:city-commission+unsubscribe@bhamgov.org).

To view this discussion on the web visit [https://groups.google.com/a/bhamgov.org/d/msgid/city-commission/CABeyTqUKP1BmJtegng2-43Giz44R7e7f\\_MmdiWPxjry-OUYEFw%40mail.gmail.com](https://groups.google.com/a/bhamgov.org/d/msgid/city-commission/CABeyTqUKP1BmJtegng2-43Giz44R7e7f_MmdiWPxjry-OUYEFw%40mail.gmail.com).

**INFORMATION ONLY**

[NATION](#)

Climate Change

Add Topic +

# Gas leaf blowers and lawn mowers are shockingly bad for the planet. Bans are beginning to spread.

*Advocates say using a commercial gas leaf blower for an hour produces emissions equal to driving from Denver to Los Angeles.*

**Trevor Hughes**

USA TODAY

Published 5:00 a.m. ET April 30, 2023 | Updated 7:24 a.m. ET May 1, 2023

DENVER – Your lawn may be the next climate change battleground. And parks. And playgrounds.

Regulators and clean-air advocates are increasingly eyeing the pollution emitted by small gasoline engines used to power lawn mowers and leaf blowers as they seek to blunt climate change. Environmentalists say using a commercial gas leaf blower for an hour produces emissions equal to driving from Denver to Los Angeles.

Among cities and states with bans or limits: California; Burlington, Vermont; and Washington, D.C. Vancouver, British Columbia, also has restrictions in place.

While many critics first attacked the small engines for the noise they make, experts say these small, two-stroke engines release shockingly large amounts of pollution – two problems that modern and increasingly affordable electric-powered equipment solves.

The absence of noisy leaf blowers is already being felt in Washington. "You used to hear them all day, everywhere you went. And now you don't," said Susan Orlins, who helped pass the district's toughest-in-the-nation ban on gas-powered leaf blowers.

**How does climate change affect you?** Subscribe to the weekly Climate Point newsletter

**READ MORE** Latest climate change news from USA TODAY

INFORMATION ONLY

---

## What states and cities have moved to ban gas lawn equipment?

California has already taken the biggest step in banning the engines, which are formally known as "small off road engines," or SOREs. California's ban phases in next year and prohibits the sale of new small gas engines. People can keep using the ones they already own and can resell used ones.

Washington, D.C., has a much stricter ban, barring the use of gas-powered leaf blowers by anyone within the district as of Jan. 1, 2022, and levying \$500 fines for violators, unless they're on federal property. The ban also allows anyone who sees or hears a gas-powered leaf blower to file a complaint – they don't need a city inspector to witness it.

Denver-area regulators are considering restrictions that primarily target large commercial and municipal users but provide exemptions for homeowners. The Denver-area ban is focused on reducing ozone pollution, which causes breathing difficulties and contributes to climate change.

The residential retail market is already responding, and most hardware and big-box stores now sell electric equipment.

“For the majority of residents who own single family homes, it’s going to be all electric, all day long,” said Daniel Mabe, founder and president of the American Green Zone Alliance. AGZA advises organizations and governments on best practices to adopt when transitioning to electric equipment but doesn't take a position on bans or restrictions.

---

## Why is gas lawn equipment being banned?

Experts say lawn and garden equipment represents about 85% of all SOREs in operation today nationally, and those engines are typically manufactured without the pollution controls used on cars.

**NATURAL GAS:** Appeals court overturns California city's attempt to ban new natural gas hookups

**GAS STOVE BANS EXPLAINED:** Are natural gas stoves actually a 'hazard'? Why are they suddenly controversial?

Virtually all small engines are two-stroke, which burn a dirtier fuel mix than vehicles do. Advocates say that in addition to the climate-changing emissions released by the engines, workers are exposed directly to their exhaust and rarely wear filters to protect their lungs.

Other people complain about the noise they make, especially when so many suburban residents now work from home.

"Transitioning to battery-powered landscaping equipment is a more sustainable alternative that would move us closer to meeting climate action goals and reduce harmful health effects," said the California-based group San Diegans for Sustainable, Equitable & Quiet Equipment in Landscaping.

---

## What's the downside of electric lawn equipment?

Critics say battery-powered machines aren't as strong as gas-powered ones, and some people also worry about having to buy new equipment, which is generally more expensive.

Mabe says someone starting a small landscaping business could buy the necessary gas-powered equipment for about \$6,000, but the electric equivalents could cost three times that.

He adds that organizations switching to electrics will need more space to store and charge batteries and may also have to upgrade their electricity service to meet overnight charging demand.

Advocates say that having a big state like California switch to electric equipment will create a marketplace that international manufacturers can count on, lowering prices overall as other states and cities enact similar bans. Like the District of Columbia, California is giving grants to small businesses that replace gas-powered equipment with electric.

## **What if I want to keep my gas lawn mower or leaf blower?**

Most existing proposals would only limit the sale of new gas-powered equipment, allowing people to keep using what they already own.

But clean-air advocates say the transition to electric equipment is inevitable as the United States works to limit emissions of greenhouse gases and air pollution. Orlins said she loaned her lawn care workers money so they could switch to battery-powered equipment.

"We decided we had to take that first step, and we are all so pleased," she added.



CITY CLERK  
CITY OF BIRMINGHAM  
P.O. BOX 3001, 151 MARTIN STREET  
BIRMINGHAM, MI 48012

**STATE OF MICHIGAN  
BEFORE THE MICHIGAN PUBLIC SERVICE COMMISSION NOTICE OF  
HEARING  
FOR THE ELECTRIC CUSTOMERS OF  
DTE ELECTRIC COMPANY  
CASE NO. U-21051**

- DTE Electric Company requests Michigan Public Service Commission's approval for reconciliation of its power supply cost recovery plan (Case No. U-21050) for the twelve months ending December 31, 2022.
- The information below describes how a person may participate in this case.
- You may call or write DTE Electric Company, One Energy Plaza, Detroit, MI 48226, (800) 477-4747, for a free copy of its application. Any person may review the documents at the offices of DTE Electric Company or on the Commission's website at: [michigan.gov/mpsccdockets](http://michigan.gov/mpsccdockets).
- A pre-hearing will be held:

**DATE/TIME:** Tuesday, May 16, 2023 at 10:00 AM

**BEFORE:** Administrative Law Judge Sally Wallace

**LOCATION:** Video/Teleconferencing

**PARTICIPATION:** Any interested person may participate. Persons needing any assistance to participate should contact the Commission's Executive Secretary at (517) 284-8096, or by email at [mpsccdockets@michigan.gov](mailto:mpsccdockets@michigan.gov) in advance of the hearing.

The Michigan Public Service Commission (Commission) will hold a pre-hearing to consider DTE Electric Company's (DTE Electric) March 31, 2023 application requesting the Commission to: 1) approve DTE Electric's 2022 Power Supply Cost Recovery (PSCR) reconciliation as proposed; 2) authorize DTE Electric to collect its total PSCR under-recovery at year-end 2022 of \$420,616,238 including interest, from all PSCR customers via a roll-over of such under-recovery as the January 2023 starting balance for the 2023 PSCR Reconciliation; and 3) grant DTE Electric further additional relief and authority as the Commission may deem necessary.

**INFORMATION ONLY**

All documents filed in this case shall be submitted electronically through the Commission's E-Dockets website at: [michigan.gov/mpscedockets](http://michigan.gov/mpscedockets). Requirements and instructions for filing can be found in the User Manual on the E-Dockets help page. Documents may also be submitted, in Word or PDF format, as an attachment to an email sent to: [mpscedockets@michigan.gov](mailto:mpscedockets@michigan.gov). If you require assistance prior to e-filing, contact Commission staff at (517) 284-8090 or by email at: [mpscedockets@michigan.gov](mailto:mpscedockets@michigan.gov).

Any person wishing to intervene and become a party to the case shall electronically file a petition to intervene with this Commission by May 9, 2023. (Interested persons may elect to file using the traditional paper format.) The proof of service shall indicate service upon DTE Electric Company's attorney, Jon P. Christinidis, One Energy Plaza, Detroit, MI 48226.

The prehearing is scheduled to be held remotely by video conference or teleconference. Persons filing a petition to intervene will be advised of the process to participate in the hearing.

Any person wishing to participate without intervention under Mich Admin Code, R 792.10413 (Rule 413), or file a public comment, may do so by filing a written statement in this docket. The written statement may be mailed or emailed and should reference Case No. **U-21051**. Statements may be emailed to: [mpscedockets@michigan.gov](mailto:mpscedockets@michigan.gov). Statements may be mailed to: Executive Secretary, Michigan Public Service Commission, 7109 West Saginaw Hwy., Lansing, MI 48917. All information submitted to the Commission in this matter becomes public information, thus available on the Michigan Public Service Commission's website, and subject to disclosure. Please do not include information you wish to remain private. For more information on how to participate in a case, you may contact the Commission at the above address or by telephone at (517) 284-8090.

Requests for adjournment must be made pursuant to Michigan Office of Administrative Hearings and Rules R 792.10422 and R 792.10432. Requests for further information on adjournment should be directed to (517) 284-8130.

For more information on how to participate in a case, you may contact the Commission at the above address or by telephone at (517) 284-8090.

The Utility Consumer Representation Fund has been created for the purpose of aiding in the representation of residential utility customers in various Commission proceedings. Contact the Chairperson, Utility Consumer Participation Board, Department of Licensing and Regulatory Affairs, P.O. Box 30004, Lansing, Michigan 48909, for more information.

Jurisdiction is pursuant to 1909 PA 106, as amended, MCL 460.551 et seq.; 1919 PA 419, as amended, MCL 460.54 et seq.; 1939 PA 3, as amended, MCL 460.1 et seq.; 1969 PA 306, as amended, MCL 24.201 et seq.; 1982 PA 304, as amended, MCL 460.6j et seq.; and Parts 1 & 4 of the Michigan Office of Administrative Hearings and Rules, Mich. Admin Code, and R 792.10401 through R 792.10448.

U-21051



There are five bills proposed by Michigan legislators, all aiming to amend sections of existing laws that govern civil rights and landlord relationships with tenants. GETTY IMAGES

# Mich. renters need more protection and the Legislature can give it to them

## Your Turn

Nancy Haynes and Jennifer Butler  
Guest columnists

Most know it is illegal to deny a service or housing to someone simply because of their

receives nearly 5 million people, but it is struggling to meet the growing need, with families waiting years to land a voucher. When they do receive one, they should, in theory, be able to move to any affordable home. In reality, however, their choices are limited because either

INFORMATION ONLY

## Your Turn

Nancy Haynes and Jennifer Butler  
Guest columnists

Most know it is illegal to deny a service or housing to someone simply because of their race, disability or religion. But federal laws do not offer the same protections from income discrimination for housing.

This means a retiree on Social Security, a parent who receives child support, a veteran who relies on disability assistance or anyone with a housing voucher can all be denied housing despite having legal, verifiable and consistent income.

Because federal protections only go so far, states have stepped in. Nearly one-third have banned this type of discrimination, with more states passing protections every year. Lawmakers in Lansing have an opportunity to do the same this spring, with several bills before both the state House and state Senate, and we believe they should. With the economic picture as murky as it is, ending this practice can actually help housing providers, too.

There are five bills proposed between chambers by Michigan legislators, all aiming to amend sections of existing laws that govern civil rights and landlord relationships with tenants:

- House Bill 4063 would expand the definition of civil rights to protect source of income.
- H.B. 4062 would prevent landlords from publishing ads or other material that discriminates against a particular source of income.
- Senate Bill 207 would prohibit income sources as a reason to be blocked from accessing real estate brokers, listings, and related services.
- S.B. 205 would ensure full and equal use of rental accommodations regardless of income source.
- S.B. 206 would define source of income to include various forms of assistance.

Rent for a typical home in the Detroit metro area has increased by nearly 36% over the past five years. This creep in housing costs gets even steeper when you consider wages have not kept pace with rapid increases in inflation and living costs. This greatly heightens the risk of renters falling into homelessness. For exposed households, relying on some sort of alternative income from public assistance is the only way to make ends meet and build for the future.

Housing Choice Vouchers are an important part of this conversation. This federal program

serves nearly 5 million people, but it is struggling to meet the growing need, with families waiting years to land a voucher. When they do receive one, they should, in theory, be able to move to any affordable home. In reality, however, their choices are limited because either some housing providers won't rent to them due to the source of their income or because of administrative challenges of working with these programs.

Studies have found that communities without source-of-income protections are far more likely to turn away voucher holders, while the cities and states with income protections help people remain housed. This legislation in Lansing, combined with expansion and improvements of the federal program, could be a game changer for struggling families across Michigan.

It's not just tenants who stand to gain. Housing providers also win.

Consider this: Voucher holders are pre-screened in order to qualify. Landlords can terminate a lease for good cause even if the tenant relies on alternative sources of income, just like any other tenant. And, these benefits come directly from government resources, offering consistent monthly payments – all positives that can help housing providers' balance sheets as recession and fears of job loss linger.

Landlords are understandably cautious about participating in these programs because of the red tape and uncertainties involved. Lawmakers should find ways to beef up housing provider education and outreach, streamline programs so that landlords feel more confident navigating these systems successfully, and improve administrative and payment methods for housing providers. If we take these steps, we will help landlords unlock more of the rental market and provide safe housing to more people.

April is Fair Housing Month. These bills put our money where our mouth is, representing a good first step in helping both tenants and landlords, and we encourage lawmakers to support this package of pro-housing bills this spring. We applaud Sens. Mary Cavanagh, Rosemary Bayer and Jeff Irwin, and Reps. Jennifer Conlin and Jason Morgan for advancing this effort to remove barriers to housing by ensuring Michigan tenants are protected from income discrimination.

*Nancy Haynes is the executive director of the Fair Housing Center of West Michigan. Jennifer Butler is the senior director for government and community relations at Zillow.*

LOCAL

## Why rubber roads are likely to become increasingly common in Michigan



**Mike Ellis**

Lansing State Journal

Published 9:30 p.m. ET April 27, 2023

LANSING — They won't be bouncy but Michigan's next roads are increasingly bound to be made with old tires, including a "road lasagna" technique already used in Ingham County.

State officials announced \$2 million in grants last month for a variety of road projects using old tires.

Ingham County received a nearly \$38,000 grant, enough to do about 750 feet of road built on top of a shredded tire base at Fitchburg and Parman roads near Leslie.

The projects tend to be small and on local roads. Most big projects use federal funding and tire rubber is considered experimental and generally can't be used on roads that get federal funding, said Kelly Jones, managing director of Ingham County's roads department.

Today's projects generally use rubber in the asphalt mix or rubber as a base and tend to be fairly small in scale, said M. Emin Kutay, an engineering professor at Michigan State University who works on rubber-modified roads.

"Typically our paving industry is slow to new things," he said. "They want to see it long-term first."

Based on his research, Kutay said experiments from the past decade or more are showing good techniques for producing mixes that can make quieter and longer lasting roads but may not be quite as good as other premium additives like polymers. When rubber-modified roads fail, it's usually a construction or mix problem and not the rubber itself, he said.

Keeping tires out of the landfill is the main reason to use rubber but there are other benefits to using their rubber for roads. Kutay said the surface can keep a dark black hue longer, and there's less noise and infirmities when the repurposed rubber is mixed properly.

Kirsten Clemens, scrap tire coordinator for Michigan's Department of Environment, Great Lakes, and Energy, said Michigan residents go through about 10 million tires a year.

"So there's a lot of tires," she said of the recycling possibilities.

Reusing tires has long been a goal and they are reused in a variety of ways: Some are burned for energy with special smoke scrubbers at landfills. Other tires get small-scale reuses like playground equipment or as planters.

There are potential hazards from scrap tire piles, she said, that lead to mosquito breeding grounds, visual nuisances and fire risks.

Tires also can't go into landfills as normal tires, Clemens added, because they could inflate with methane gas and rise to the surface, which causes problems for landfills.

Dave Ouwinga and his Porous Pave Inc. company, based in Grant, use truck tires to make porous surfaces like golf cart paths, driveways and rings around trees in cities.

Those metal grates around trees can be a liability for tripping and a maintenance time-killer for cities, Clemens said.

Like Ingham County, his company is one of several entities that were part of the \$2 million EGLE grant announced in March. Ouwinga company's \$60,000 will go toward a washing system and tests of porous pavement technology.

Ouwinga said he sometimes has to work around not having enough tires. They typically use semi tires, which don't have the nylon that consumer tires do.

"We've been having a little bit of a problem with truck tires," he said.

Ouwinga shared that his suppliers grind the tires into a small mix using 1/4-inch to 5/16-inch chunks held together with urethane glue. When they're low on tires, they either need to wait a few weeks to get more semi tires or mix in some consumer tires.

**INFORMATION ONLY**

"There's a lot of demand," Ouwinga said. "You're seeing a number of new applications for tires."

Ouwinga has learned that football fields are moving over to using a smaller mix, crumb size, instead of sand underneath artificial turf.

"You'll see a black streak when a player drags their foot," he said.

EGLE's \$2 million grant will go to a half dozen projects:

\$577,000 to Cobolt Holdings for equipment to process off-road tires that could be used for agricultural mats

\$60,000 for Porous Pave for a rock washing system and a project with Goodwill locations in West Michigan that will be providing plastic

About \$420,000 for a 2.3-mile rehabilitation of Dixie Highway in Saginaw County

Nearly a half million dollars for two 16-mile pavement sealing projects, in Bay and Joseph counties

About as much for a one mile stretch of paving on Midland Road in Bay County.

\$38,000 this year for Fitchburg Road in Ingham County

The Ingham County project, expected to be completed in 2024, would use tire shreds as a base and would use about 250,000 commercial tires.

She said a Belleview Road project, which used tires as a base over wetlands, "is performing well."

That project is called a "road lasagna" for the way it stacks materials, Clemens said. She said the road once had 30 inches of asphalt and was paved over whenever it sank, despite the extra weight only making it sink faster.

*Contact Mike Ellis at [mellis@lsj.com](mailto:mellis@lsj.com) or 517-267-0415.*

**INFORMATION ONLY**